

3,6x7,2 Meter Pergola Elektrisch, Aluminium, LED

Montageanleitung - DE

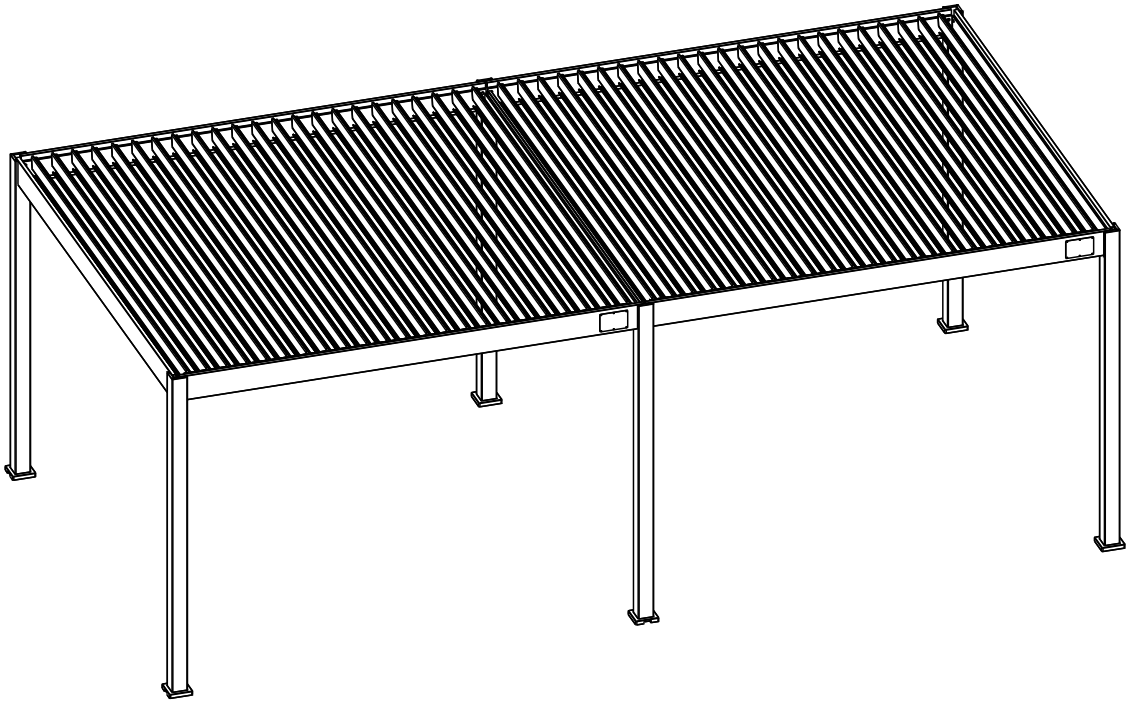

E-Deluxe Plus Aluminium Pergola 3,6×7,2 Meter

Diese Instruktionen müssen im gesamten Verlauf des Produkt-Lebenszyklus aufbewahrt werden. Wir raten Ihnen, diese sehr sorgfältig zu lesen, bevor Sie mit dem Aufbau beginnen.

Der Verbraucher ist für jegliche Schäden oder Verletzungen, die durch inkorrekte oder unsachgemäße Installation verursacht wurden, verantwortlich.

Notwendiges Werkzeug und Sicherheitsausrüstung (nicht beiliegend)

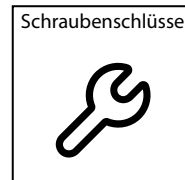
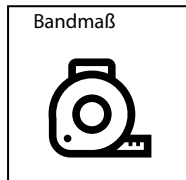
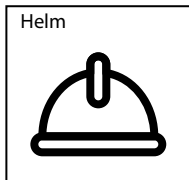
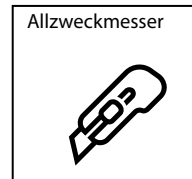
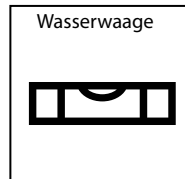
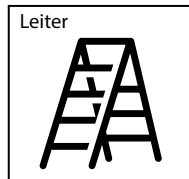

2D Fundamentmessung (Dimensionen in mm)

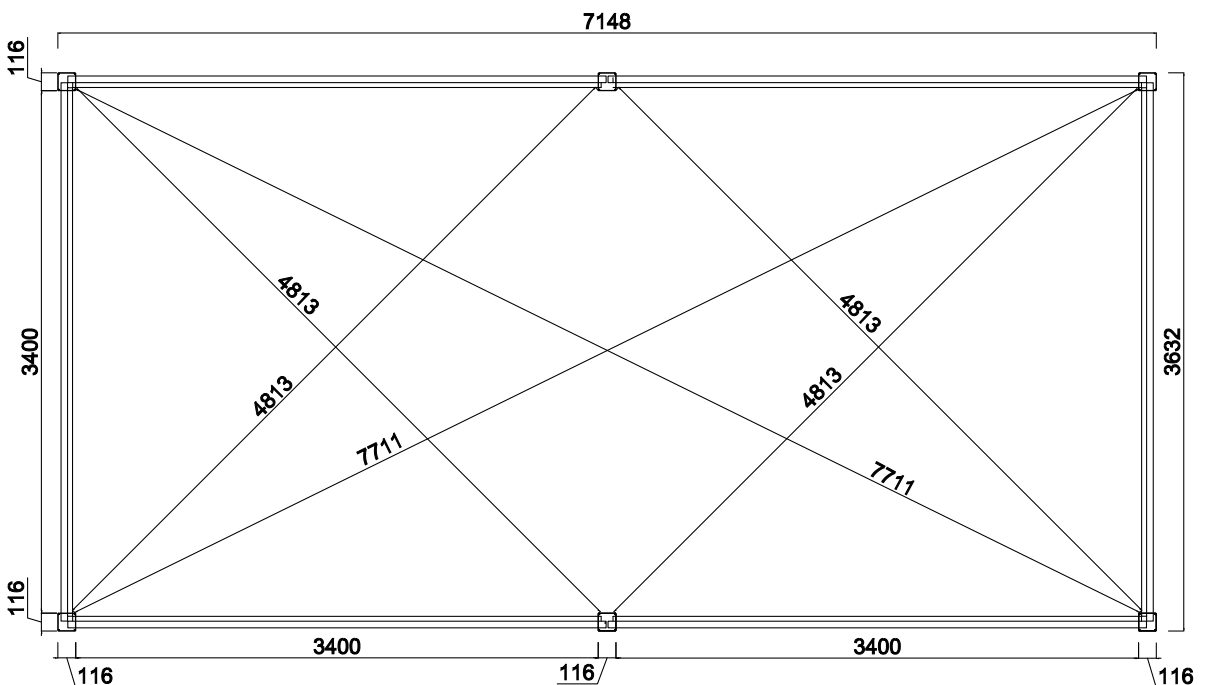

3D Fundamentmessung (Dimensionen in mm)

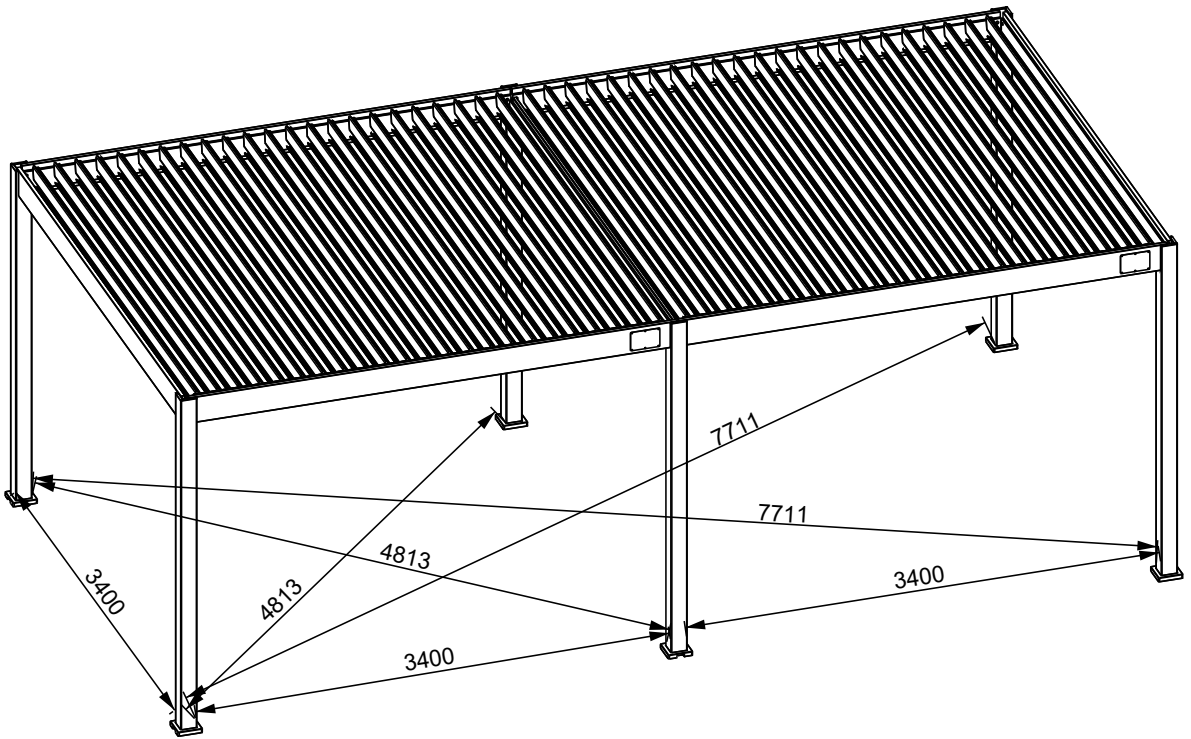

Vorsicht bei der Verwendung

Dieses Produkt sollte nicht unter extremen Wetterbedingungen verwendet werden: Sturm, starker Wind, Hagel und Schnee. Wir garantieren die Widerstandsfähigkeit der Pergola bei Windgeschwindigkeiten bis zu 88km/h und ein Maximum an Schnee mit Gewicht von 50kg/m².

Bei starkem Wind oder Schneefall empfehlen wir dringend, die Lamellen offen zu lassen. Um gute Funktionsbedingungen Ihrer Lamellen aufrechtzuerhalten, räumen Sie sie bitte von jeglichem Schnee frei.

Unsere Pergola hält starkem Regen stand, wir können jedoch aufgrund einiger extremer Wetterbedingungen keine 100 %ige Wasserdichtigkeit garantieren.

Außergewöhnliche Witterungsverhältnisse können die perfekte Abdichtung des Produkts beeinträchtigen.

Um Schäden und Verletzungen zu vermeiden, empfehlen wir, nicht auf das Dach oder andere Strukturen der Pergola zu klettern.

TIPPS UND SICHERHEITSHINWEISE

Je nach Standort und Fläche kann eine Baugenehmigung für die Konstruktion nötig sein. Stellen Sie sicher, dass Sie sich vor der Montage bei Ihren örtlichen Behörden erkundigt haben, um die erforderlichen Informationen zu erhalten.

Montage des Produkts:

- Mindestens 2-3 Personen erforderlich
- Schutzfolie entfernen (dauert ca. 1 Stunde)
- Kinder nicht in die Nähe des Montagebereichs lassen
- Vorsicht vor Einklemmgefahr
- Schrauben erst festziehen, wenn das gesamte Produkt montiert ist
- Alle Montageschritte müssen sorgfältig befolgt werden
- Die Nivellierung der Struktur auf allen Seiten prüfen
- Pergola erst verankern, wenn das gesamte Produkt montiert ist

Am Produkt dürfen keine Änderungen vorgenommen werden. Vom Benutzer manipulierte Produkte sind nicht von der Garantie abgedeckt und erlöschen.

Der Standort sollte sorgfältig ausgewählt werden. Es wird empfohlen, die Pergola nicht an einem regnerischen Tag, bei Wind, oder unter einem überhängenden Baum zu montieren.

Die Pergola muss auf einem ebenen Fundament montiert werden. Es wird empfohlen, sie auf einer Zementplatte oder an jedem Pfosten auf ca. 25 x 25 cm großen Betonplatten zu installieren. Bitte verankern Sie die Pergola ordnungsgemäß mit Spreizschrauben im Boden.

Wenn Sie Ihre Pergola in der Nähe Ihres Hauses oder eines Gebäudes montieren möchten, prüfen Sie bitte, ob Dachrinnen zur Wasserableitung vorhanden sind.

Sollten diese Anweisungen nicht oder nur teilweise befolgt werden, erlischt die Garantie durch den Verkäufer.

WARTUNG

Regelmäßige Wartung ist notwendig, um die Langlebigkeit und das ästhetische Erscheinungsbild zu gewährleisten.

Wir empfehlen:

- Reinigen Sie Ihre Pergola ein- oder zweimal im Jahr mit frischem Wasser und einem Schwamm oder Tuch.
- Verwenden Sie keine Reinigungsmittel oder Scheuermittel.
- Überprüfen Sie regelmäßig (mindestens einmal im Jahr) den festen Sitz der Schrauben.
- Ölen Sie die Befestigung regelmäßig (mindestens einmal im Jahr).
- Stellen Sie sicher, dass nichts den Wasserfluss in den Dachrinnen behindert (Blätter, Zweige...).
- Entfernen Sie Wasser, das sich um die Beine der Pergola herum stauen könnte (heben Sie die Pfostenschürzen an).

GARANTIE

Diese Garantie deckt nicht ab:

- Normale Abnutzung und Verschleiß der Produkte.
- Verlust oder Bruch von Teilen während des Auspackens oder der Installation.
- Mangelnde Sorgfalt, Vernachlässigung, Vandalismus, Aufprall auf Fremdkörper, Gewalt, Kontakt mit abrasivem Material, Produktästhetik, Demontage, Wiederaufbau oder Standortwechsel.
- Höhere Gewalt: Hagel, starker Wind, Sturm, Schnee, Überschwemmung, Blitzeinschlag usw.
- Manipulationen am Produkt durch den Benutzer.

Die Garantie umfasst nur den Ersatz von Ersatzteilen oder des gelieferten Produkts, eine Rückerstattung erfolgt nicht.

Alle Garantieansprüche müssen bei der Verkaufsstelle (Geschäft oder Website) geltend gemacht werden, bei der das Produkt gekauft wurde.

LISTE DER TEILE (PRO KARTON)







Bevor Sie mit der Montage Ihrer Lamellenpergola fortfahren, müssen Sie überprüfen, ob alle aufgeführten Teile enthalten und unbeschädigt sind. Fehlende Teile müssen innerhalb von 10 Tagen nach der Lieferung gemeldet werden.

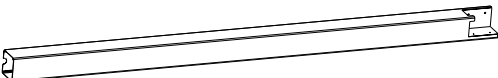
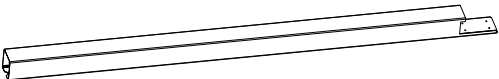



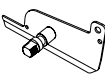
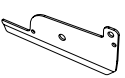
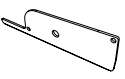

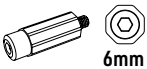
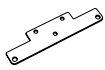









Sie können entweder über Ihren örtlichen Outlet-Store gehen oder die Anfrage direkt auf unserer Website stellen.





Werfen Sie die Verpackung nicht weg, ohne sicherzustellen, dass das Produkt ordnungsgemäß funktioniert.



KARTON 1/7 (PFOSTEN UND LOSE TEILE)

Referenz	Teile	Menge
A0		4
A0-1		2

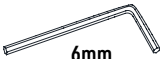



Referenz	Teile	Menge
I0		6
J0		6
K0		2
L0		44
L0-1		46
M0		90
M0-1		90
Q0		24
EO-1		2
RO		24
SO		92

Referenz	Teile	Menge	
T0	 10x80	24	
U0	 Kontermutter	136	
U0-1	 Kunststoffmutter	46	
U0-3	 M14	2	
V0		228	
W0	 4x16	 PH2	184
W0-1	 5x19	 5mm	6
X0	 6x40	 4mm	90
X0-1	 6x35	 4mm	24
X0-2	 6x20	 4mm	46
X0-3	 6x16	 4mm	4



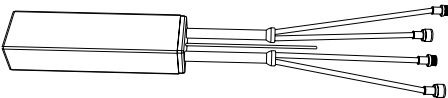

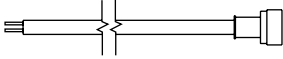
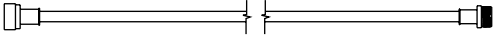
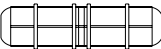
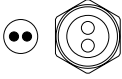
Referenz	Teile	Menge
Z0-1	 4mm	1
Z0-2	 4mm	1
Z0-3	 6mm	1
Z0-4	 6mm	1

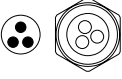
Referenz	Teile	Menge
Z0-5	 10mm	1
Z0-6	 PH2	1
Z0-7		1

Elektrische Produkte

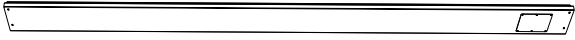
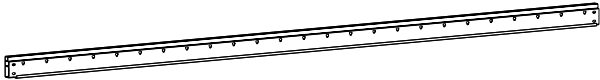
Referenz	Teile	Menge
E-C	Controller 	1
E-R	Fernbedienung 	1
E-P	Stromkabel (M15) 	1
E-P1	Motoranschlusskabel (M12) 	1
E-W2	Wasserdichte Verbindung (2)  	1
E-W3	Wasserdichte Verbindung (3)  	1

KARTON 2/7 (BALKEN)

Referenz	Teile	Menge
B1	 *enthält Motor	2
BO-1		2
CO		2
CO-1		2
FO		1



ACHTUNG!

Verbindungsstange (FO) und Bürste innen!

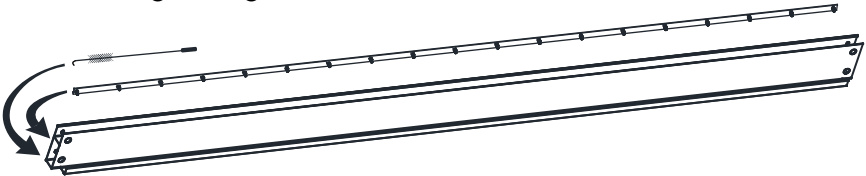



Elektrische Produkte

E-T	 <p>Transformator</p>	1
-----	--	---

KARTON 2/7 (BALKEN)

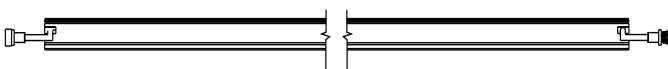
LED Produkte

Referenz	Teile	Menge
LED1		6
L-B		1

KARTON 3/7 (LAMELLEN)

Referenz	Teile	Menge
GO		9

KARTON 4/7 (LAMELLEN)

Referenz	Teile	Menge
GO		9

KARTON 5/7 (LAMELLEN)

Referenz	Teile	Menge
GO		9

KARTON 6/7 (LAMELLEN)

Referenz	Teile	Menge
GO		9

KARTON 7/7 (LAMELLEN)

Referenz	Teile	Menge
GO		10

MONTAGEANLEITUNG

Schritt 1: Rahmen & Motor

Schritt 2: Lamellen montieren

Schritt 3: Lamellen installieren & Anschluss

Schritt 1: Rahmen & Motor

Hinweise:

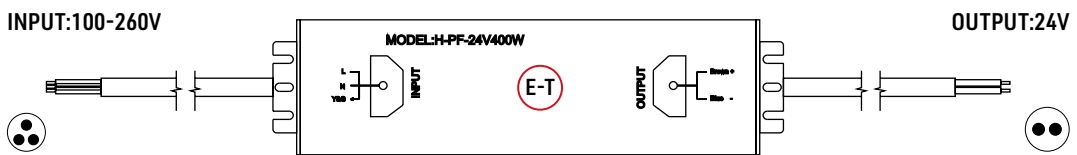

1. Bitte setzen Sie den Transformator in den Seitenträger ein, der sich in der Nähe des Motors befindet.
2. Führen Sie das Eingangskabel des Transformators durch den Pfosten und ziehen Sie dann die Leitung aus der Kerbe an der Basis des Pfostens, um den Strom anzuschließen.
3. Bitte schließen Sie die Verkabelung gemäß der folgenden Abbildung an.

E-T	 <p>Transformator</p>	1
-----	--	---

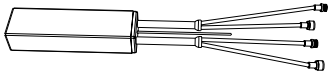

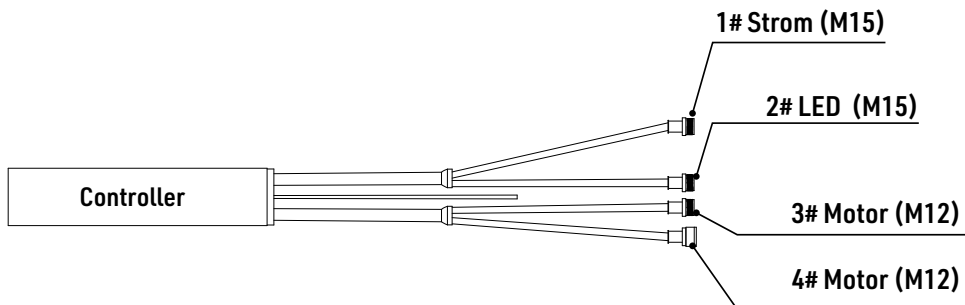
E-C	 <p>Controller</p>	1
-----	---	---

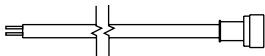
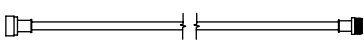

E-P		1
E-P1		1
E-W2		1
E-W3		1

Schritt 1: Rahmen & Motor

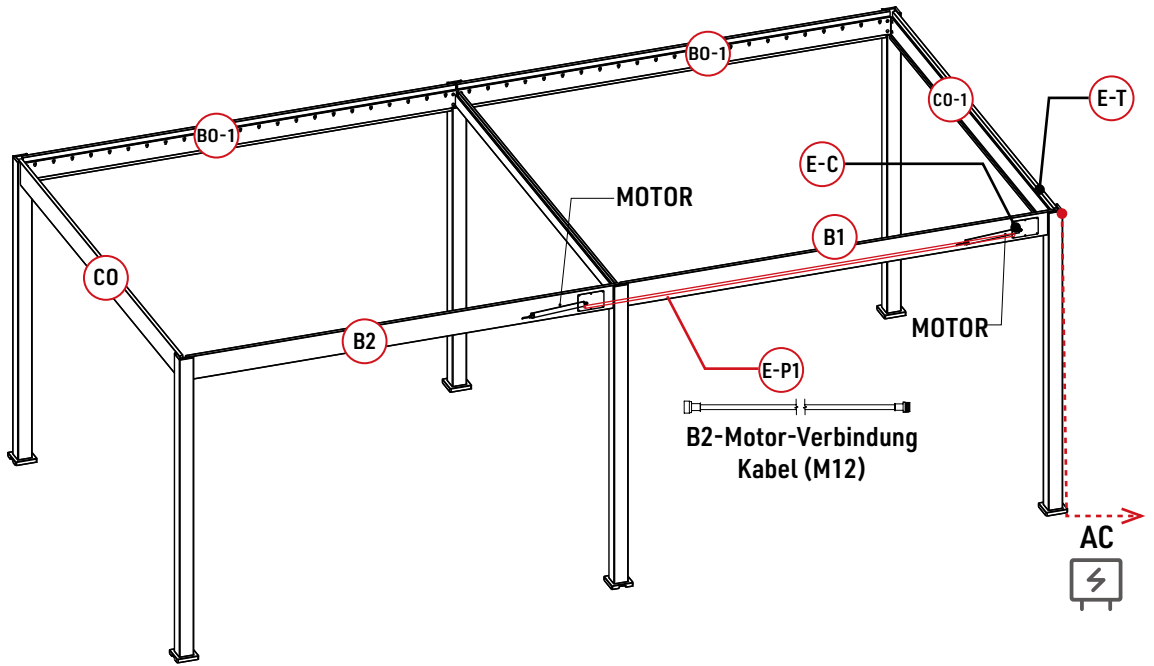

Schaltplan

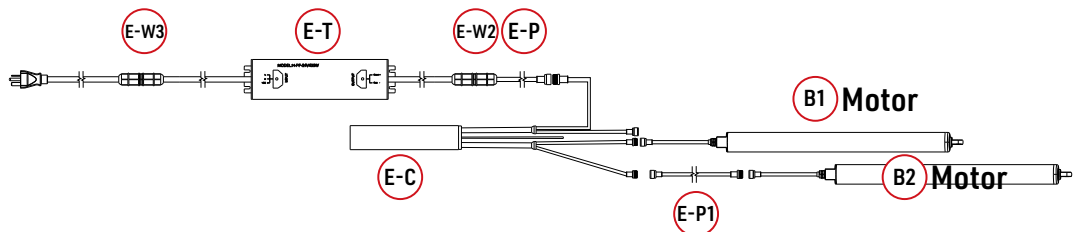

Schritt 1: Rahmen & Motor 1-1

Teile

A0		4			
A0-1		2			
E-P		1			
IO		6	XO-1		24
JO		6			
E-T		1			

Werkzeuge

Z0-1		1
Z0-2		1

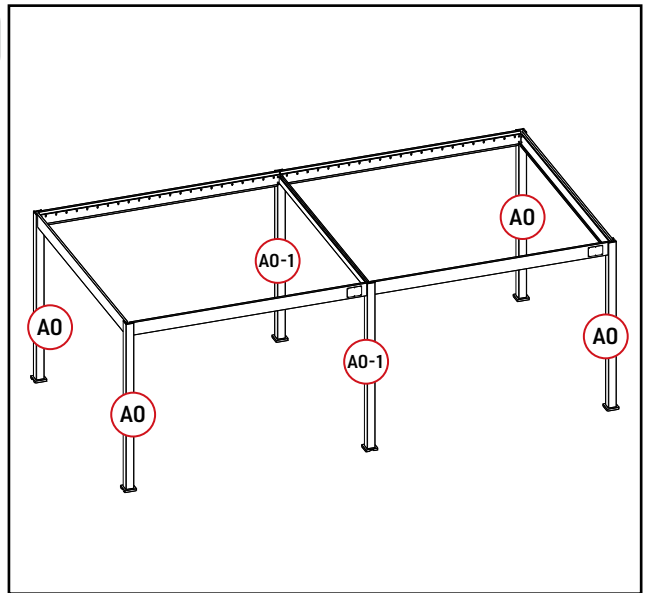

Bitte verbinden Sie die Ausgangsleitung (E-T) mit dem Stromkabel (E-P) des Transformators, indem Sie die wasserdichten Verbindungen (E-W2) verwenden.

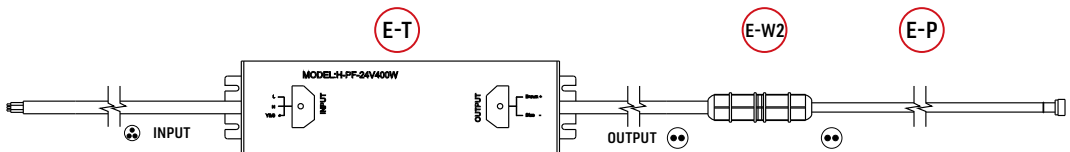

- Bitte stecken Sie die Eingangsleitung des Transformators in den Hohlraum des Pfostens.
- Ziehen Sie die Eingangsleitung aus dem Abfluss-Ausgang des Pfostens.
- Installieren Sie die Platte und den Rand des Pfostens, nachdem Sie die Eingangsleitung herausgezogen haben.

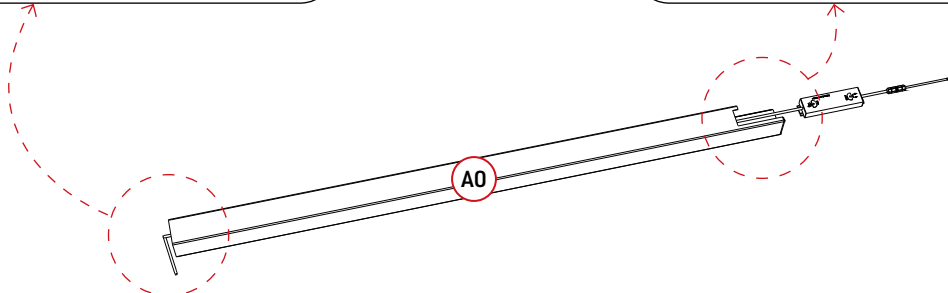
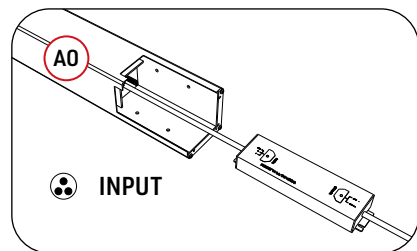
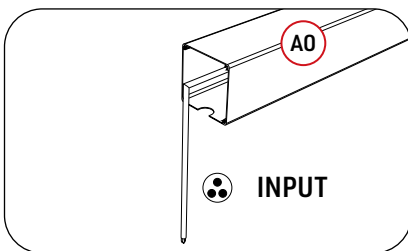

Setzen Sie die Schürze (IO) auf den Pfosten (A0). Beachten Sie dabei, dass die Kerbe an der Schürze und der Abfluss-Auslass des Pfostens aufeinander ausgerichtet sein müssen. Siehe Abbildung unten.

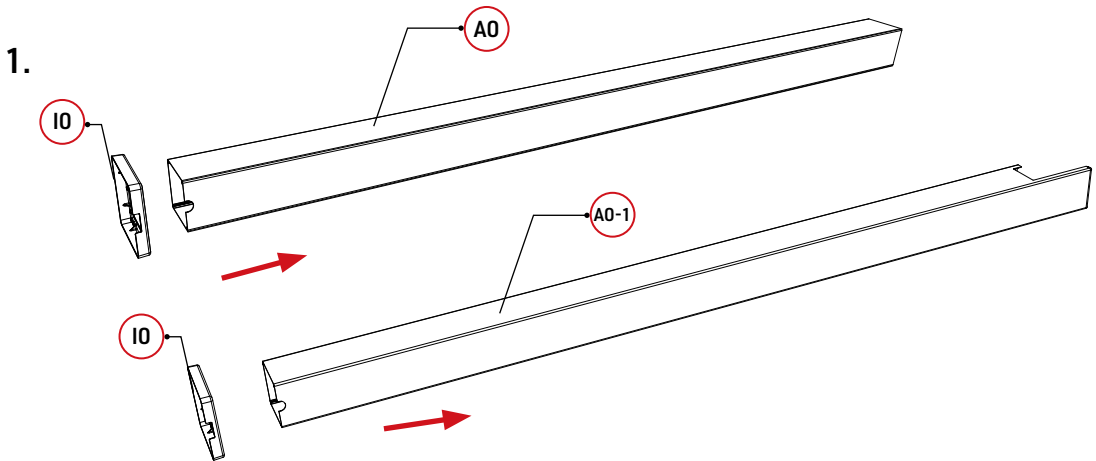

2. Installieren Sie die Platte

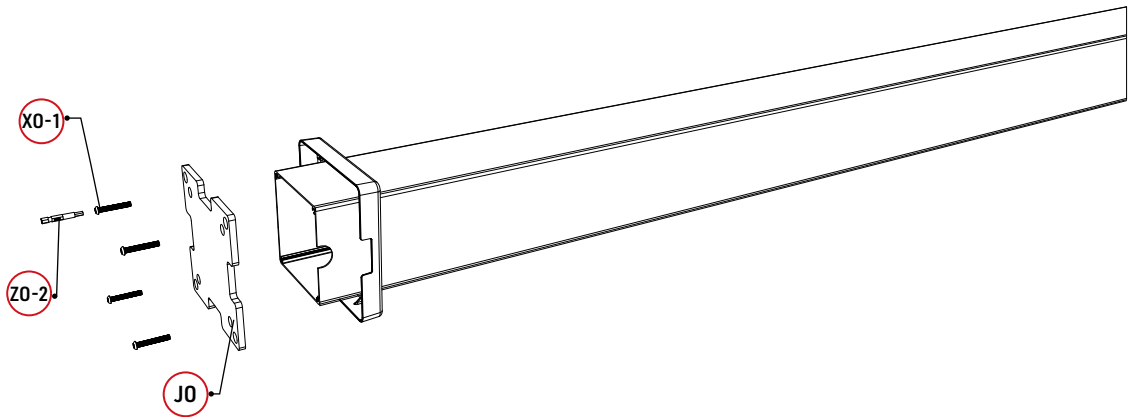

3. Festziehen

Verwenden Sie den Pistolenbohrer, um die Schrauben an der Platte zu befestigen.

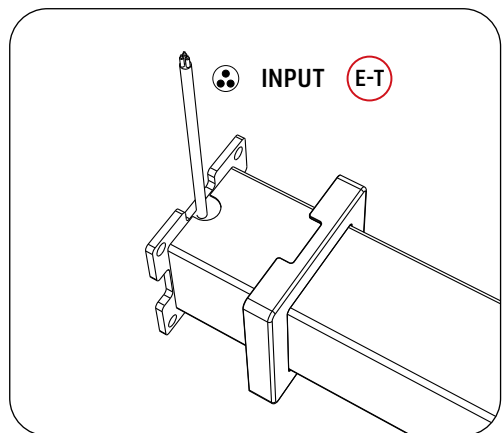
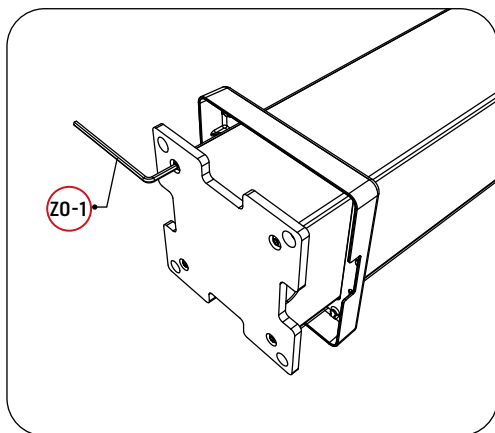

Schritt 1: Rahmen & Motor 1-2

Teile

CO		1
CO-1		1

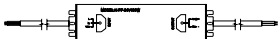
E-T		1
-----	---	---

Transformator

Q0		8
----	---	---

Werkzeuge

Z0-3		1
Z0-4		1

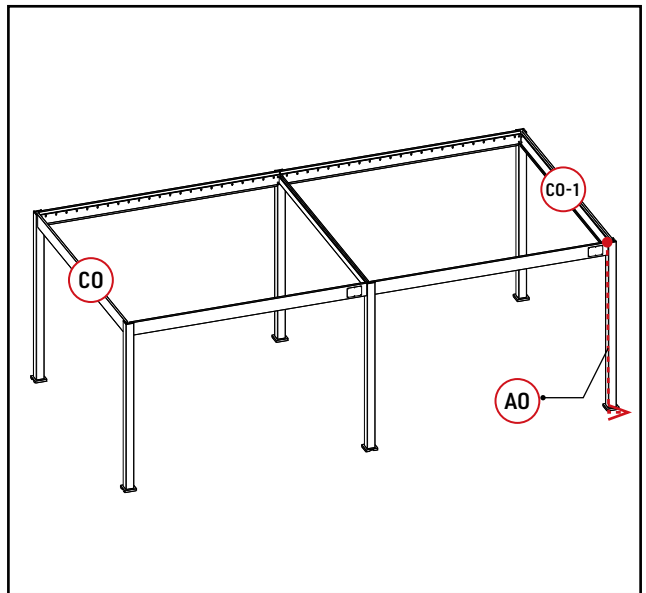

Setzen Sie den Transformator in den Hohlraum von CO-1 ein. Achten Sie darauf, genügend Länge für das Stromkabel freizuhalten.

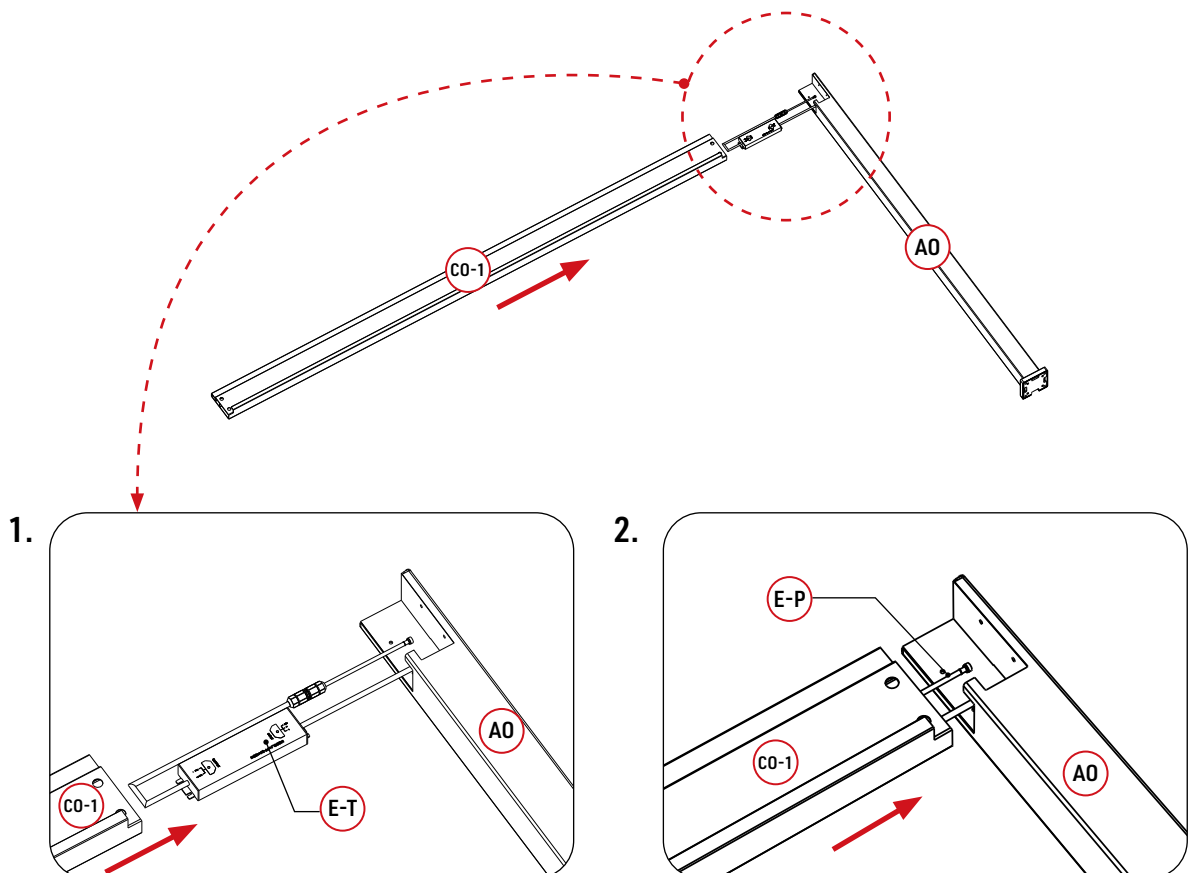

Verbinden Sie den Balken (CO-1) mit dem Pfosten (AO), wie in der Abbildung unten dargestellt.
Denken Sie daran, das Stromkabel (E-P) außerhalb des Balkens zu verlegen.

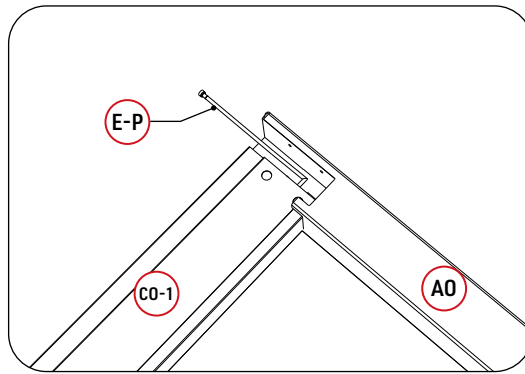

Mit dem Pistolenbohrer die Schrauben am Pfosten befestigen, dann die Schrauben mit dem Schraubenschlüssel festziehen.

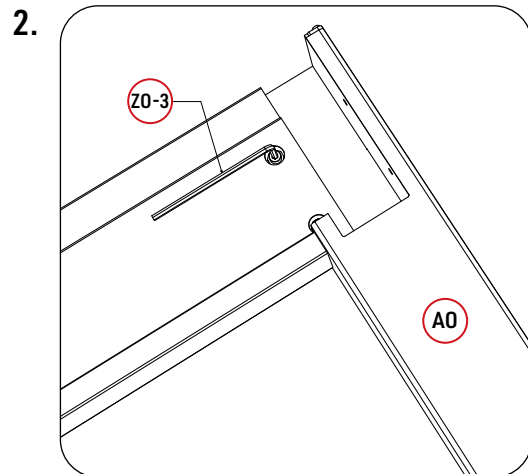
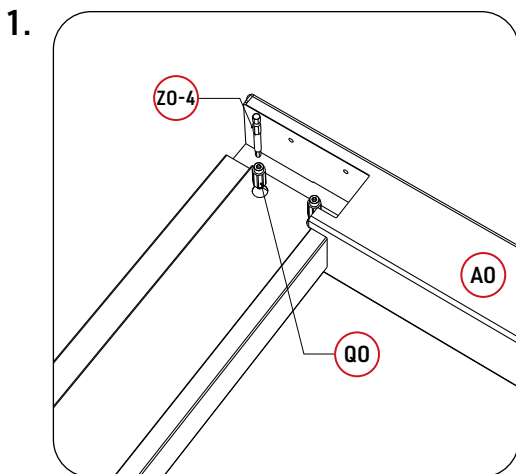
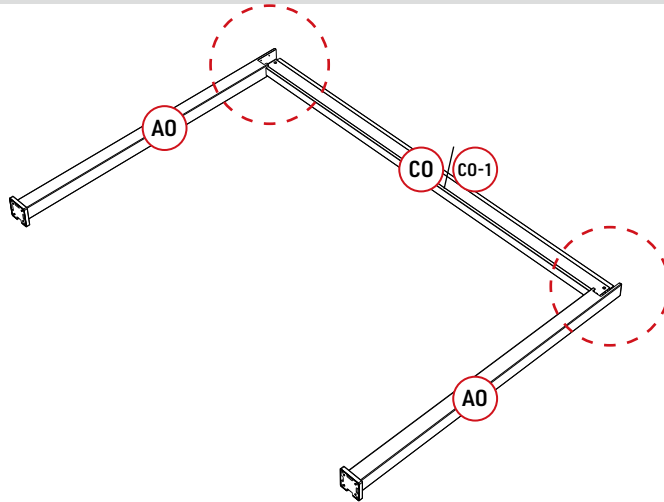



Schritt 1: Rahmen & Motor 1-3

Teile

B1		1
B0-1		1

Q0		8
----	---	---

Werkzeuge

Z0-3		1
Z0-4		1

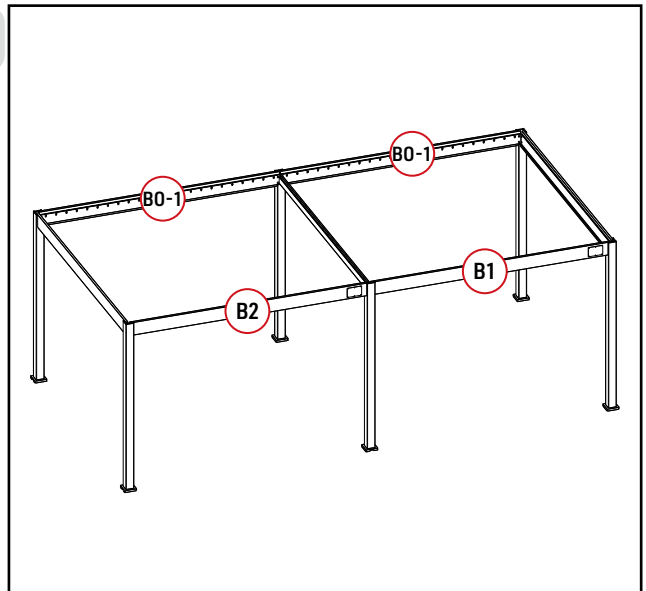

Nehmen Sie die Abdeckung vom Träger mit dem Motor ab, ziehen Sie dann das Kabel des Motors heraus und schließen Sie es an den Regler an.

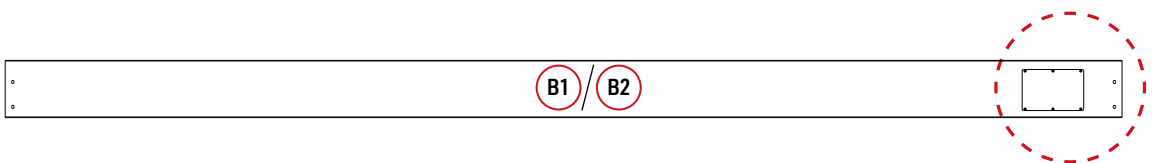

1.

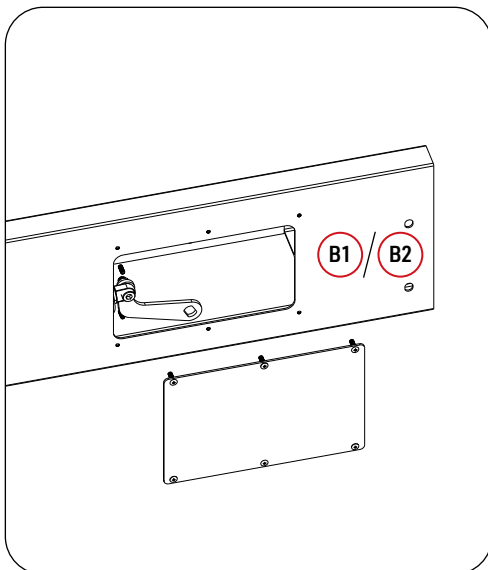

2.

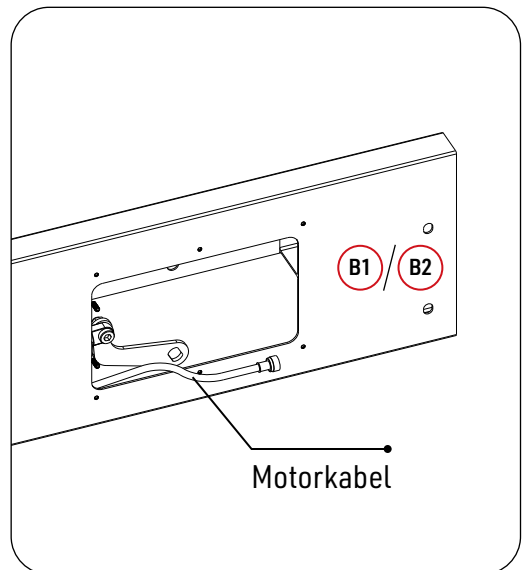

Verbinden Sie die Balken mit den Pfosten

1.

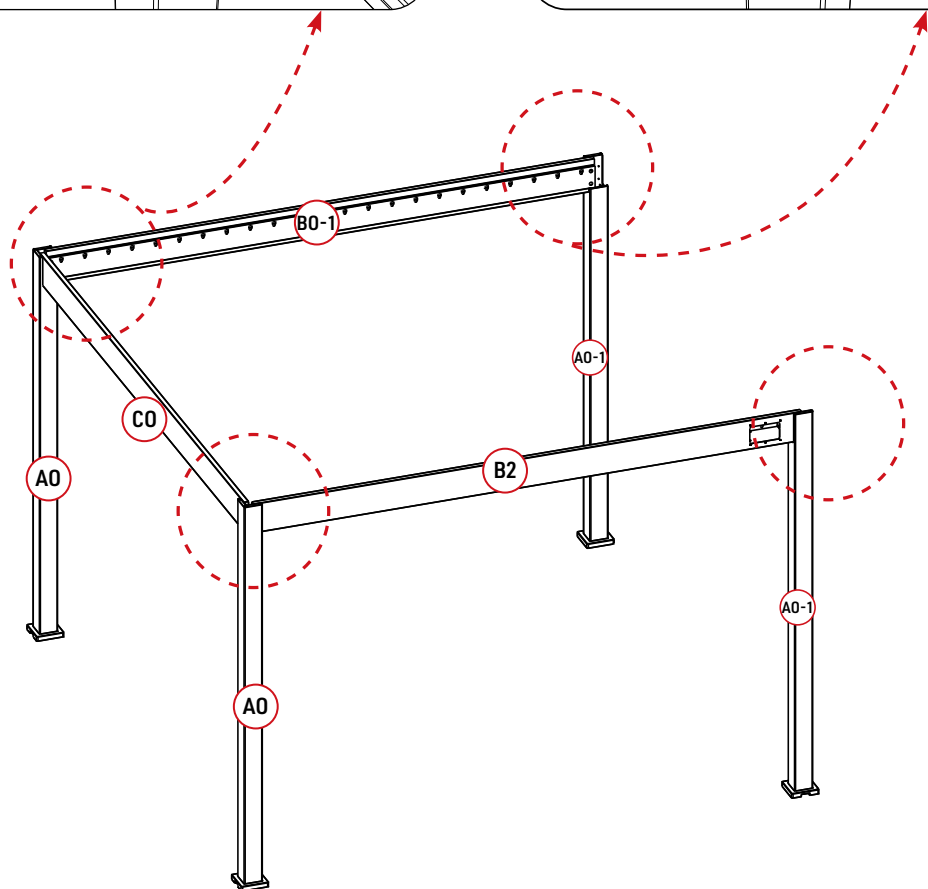
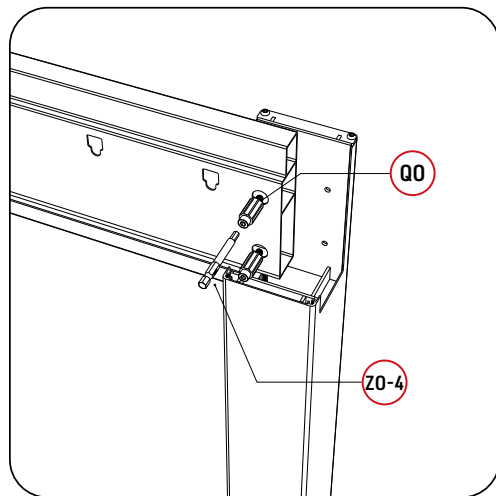
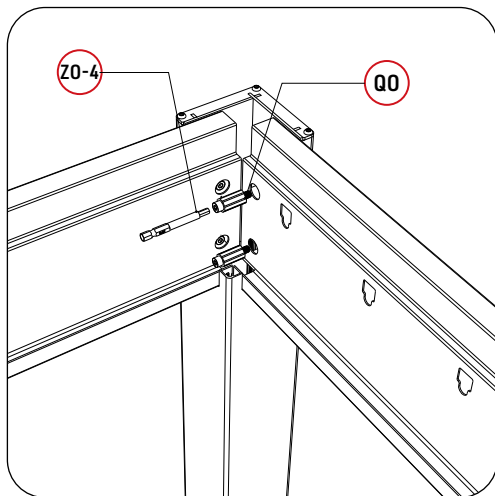

Schritt 1: Rahmen & Motor

1-3

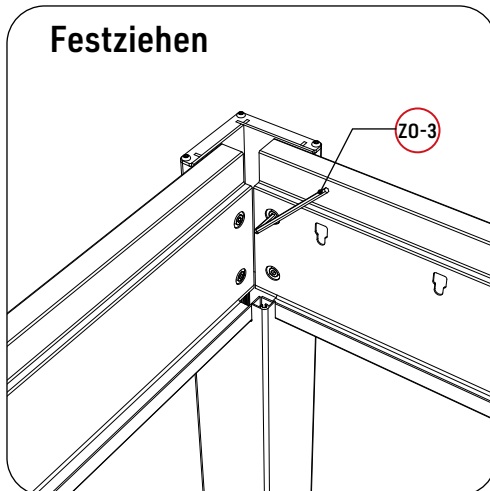
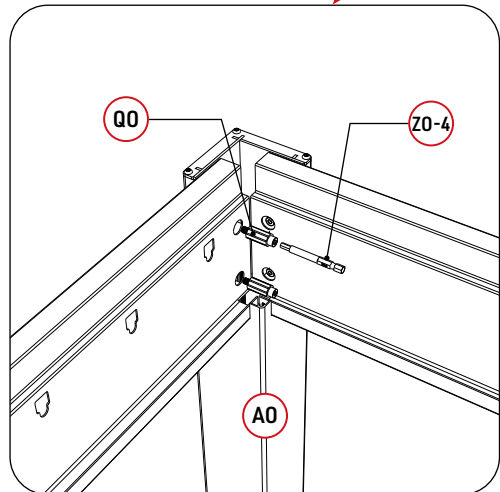
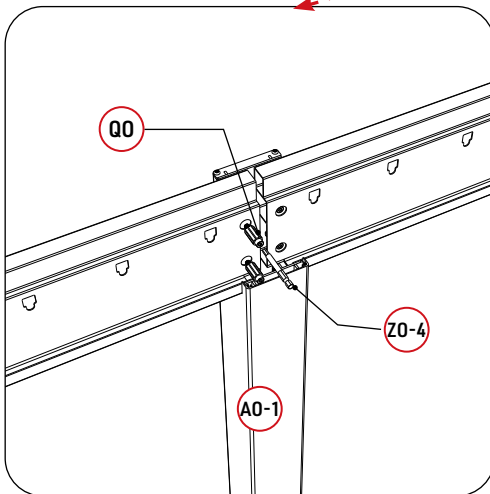
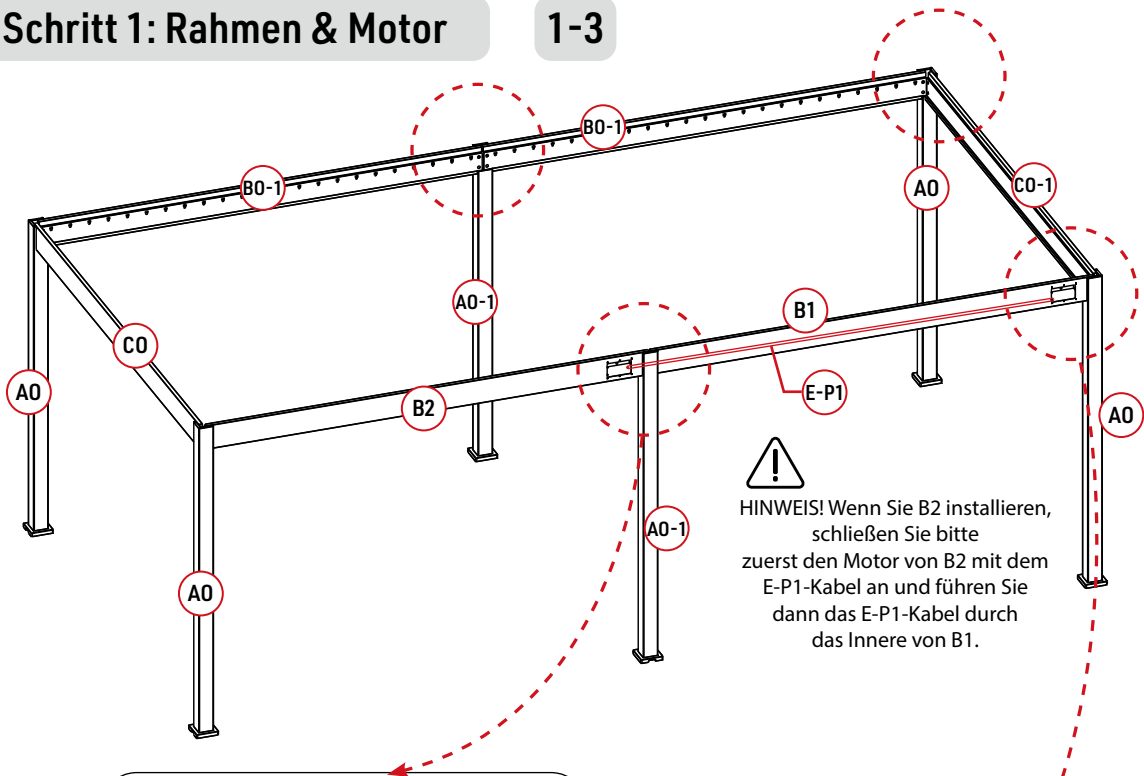

Mit dem Pistolenbohrer die Schrauben auf der Platte befestigen, dann die Schrauben mit dem Schraubenschlüssel festziehen.

Schritt 1: Rahmen & 1-4

Teile

EO		1
----	---	---

EO-1		2
------	---	---

WO-1		6
------	---	---

XO-3		4
------	---	---

Werkzeuge

ZO-1		1
------	---	---

ZO-2		1
------	---	---

ZO-7		1
------	---	---

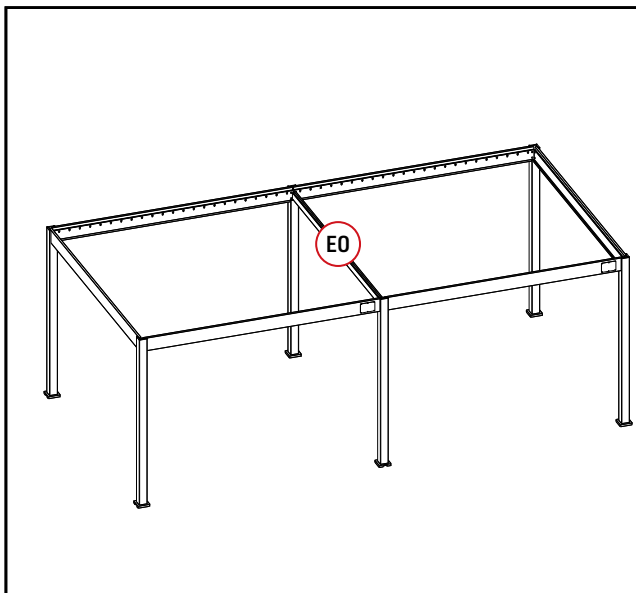

Verbinden Sie die Balken mit den Pfosten

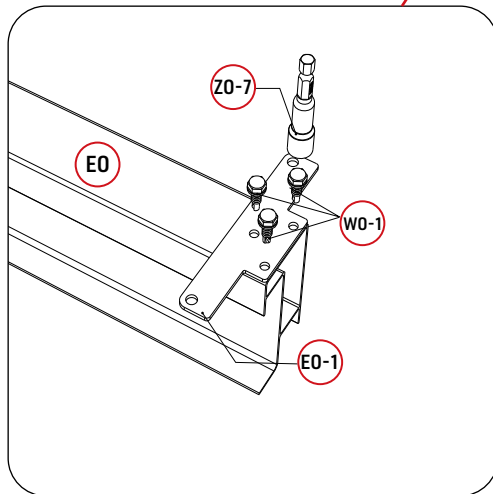
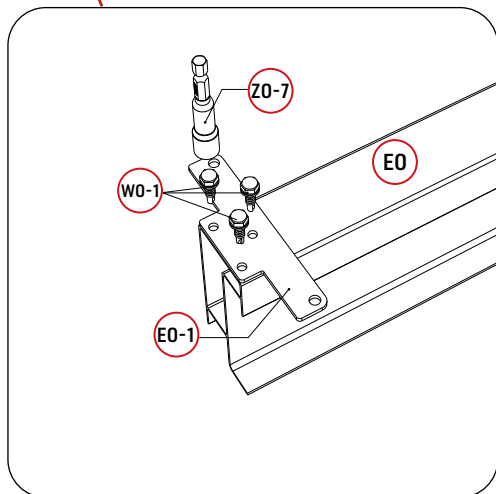
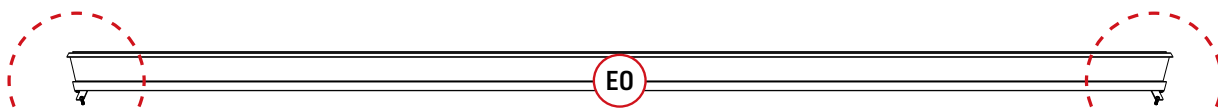

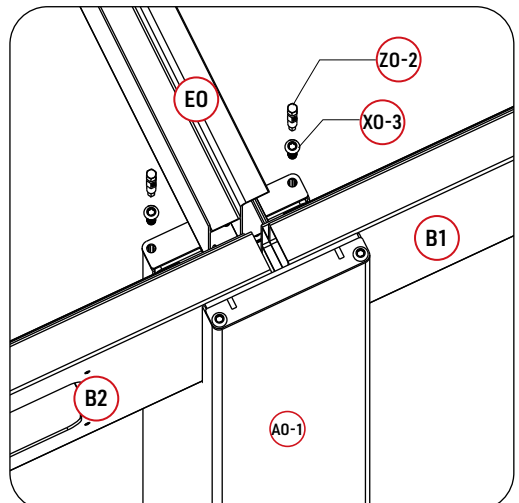
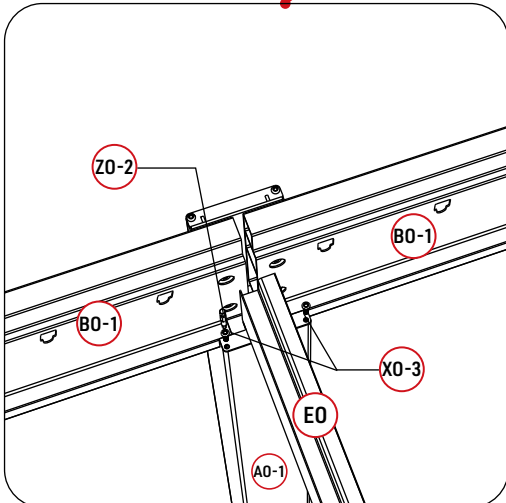
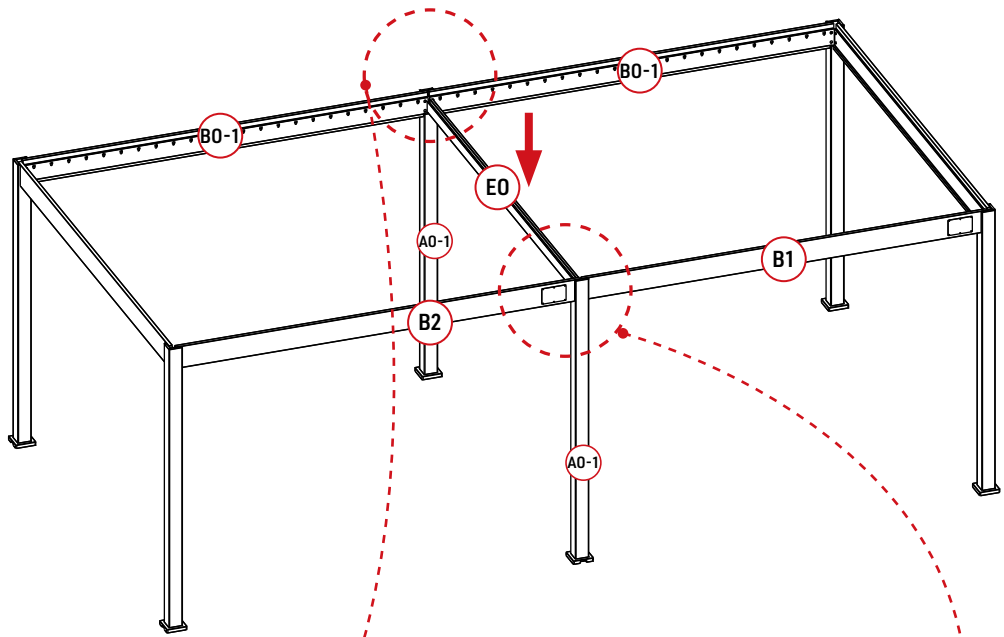



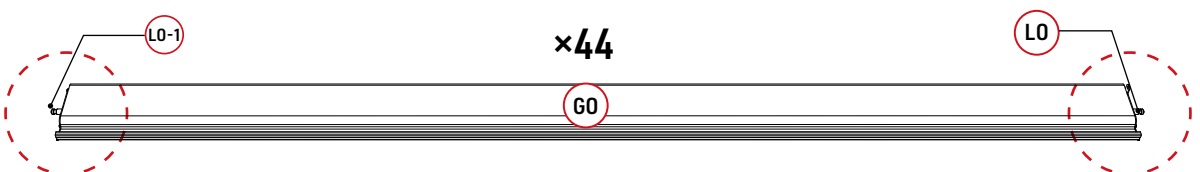
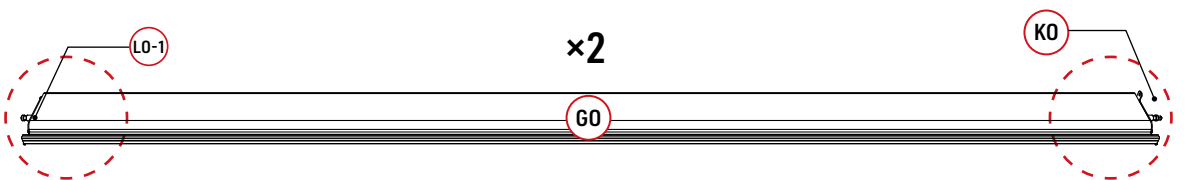
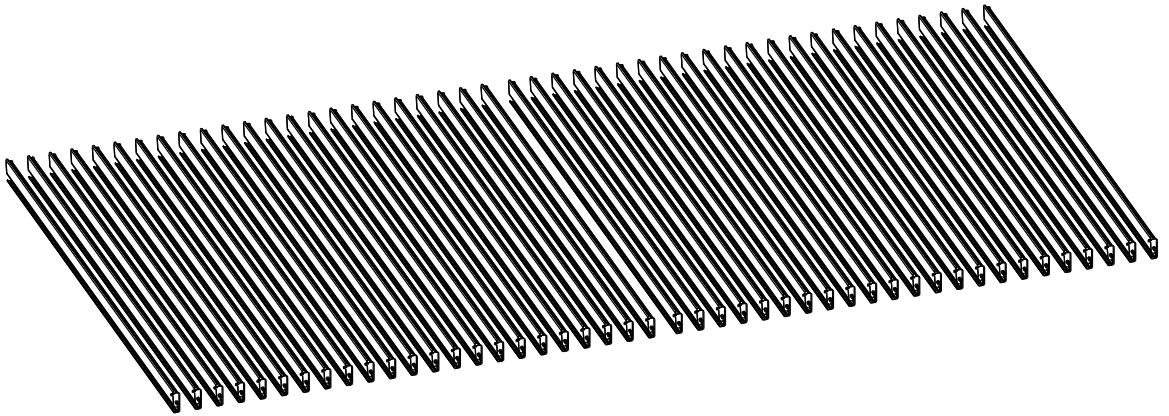



Schritt 2: Lamellen montieren





Schritt 2: Lamellen montieren

2-1

Teile

LO		44	MO-1		90	VO		90
LO-1		46	XO		90			
MO		90	UO		90			

Werkzeuge

ZO-3		1
ZO-4		1

Hinweis: Um ein Brechen der Kunststoffteile (MO) beim Einsatz der Pistolenbohrmaschine zu vermeiden, verwenden Sie bitte eine geringe Drehkraft.

Es sollte darauf hingewiesen werden, dass das Teil MO nicht zu fest angezogen werden darf, insbesondere bei der Verwendung eines Akkuschaubers.

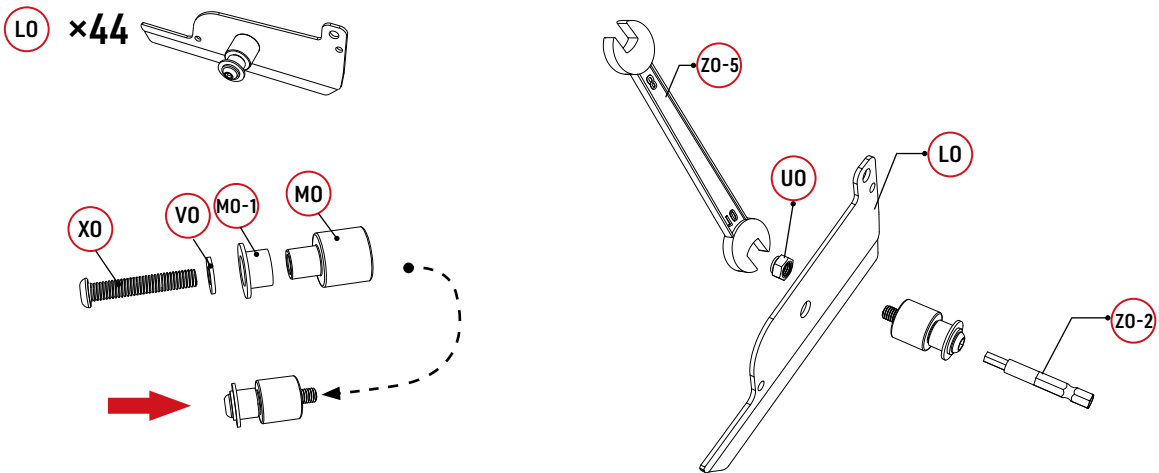



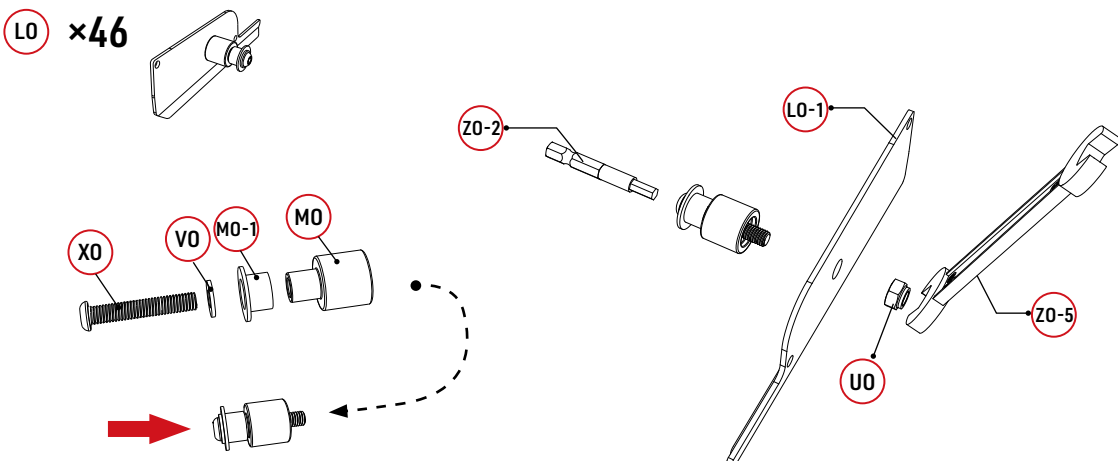



Lamellen-Dichtungsplatte





Schritt 2: Lamellen montieren 2-2

Teile

GO		46
KO		2
LO		44
LO-1		46
WO	 	184

Werkzeuge

ZO-1	 4mm	1
ZO-2	 4mm	1
ZO-6	 PH2	1

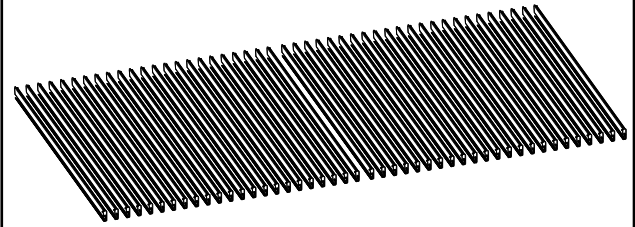

Endkappen mit den ersten Lamellen verbinden (KO)

Vervollständigungsdiagramm

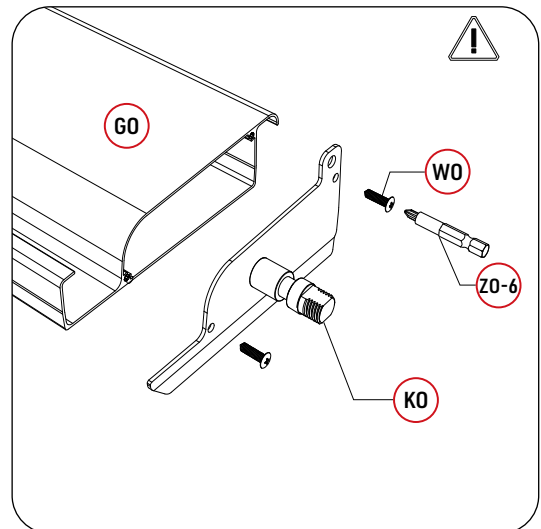
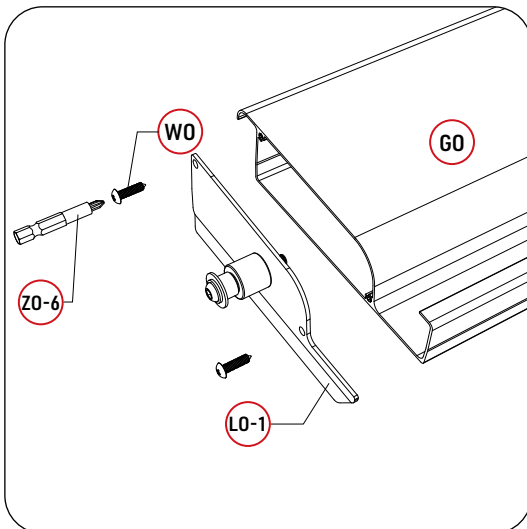
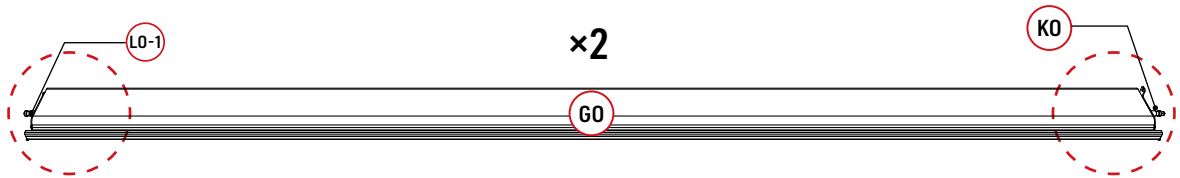

Endkappen mit den restlichen Lamellen verbinden (LO)

Vervollständigungsdiagramm

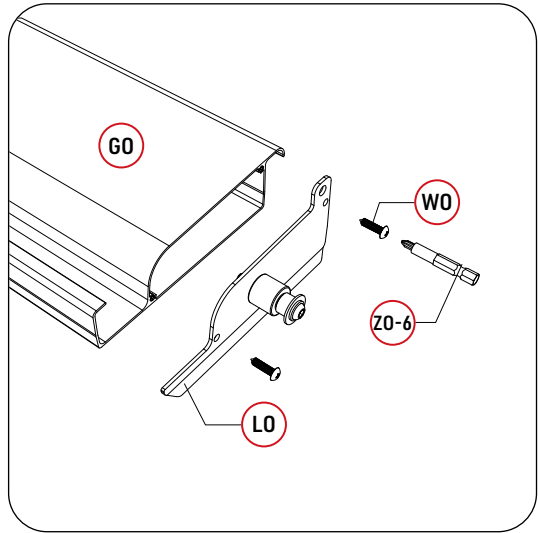
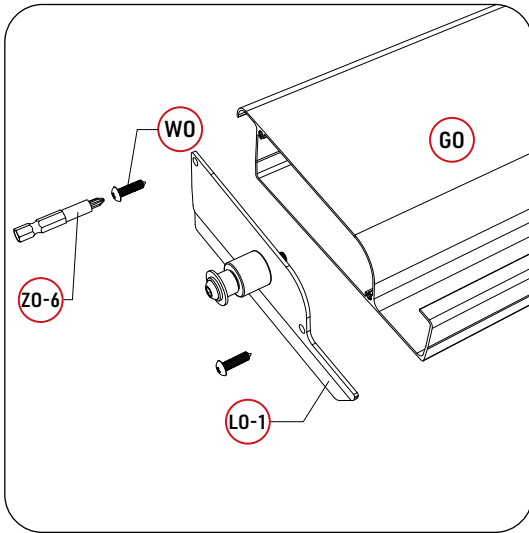
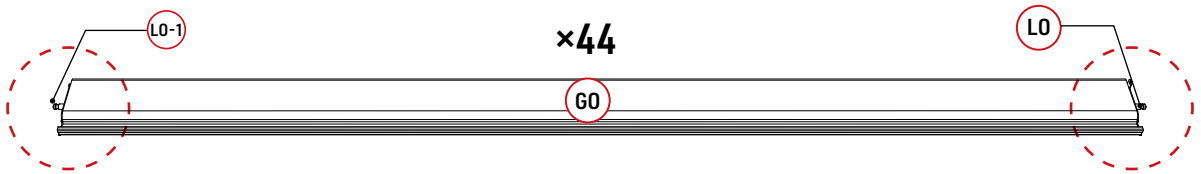

Schritt 3: Lamellen installieren & Anschluss

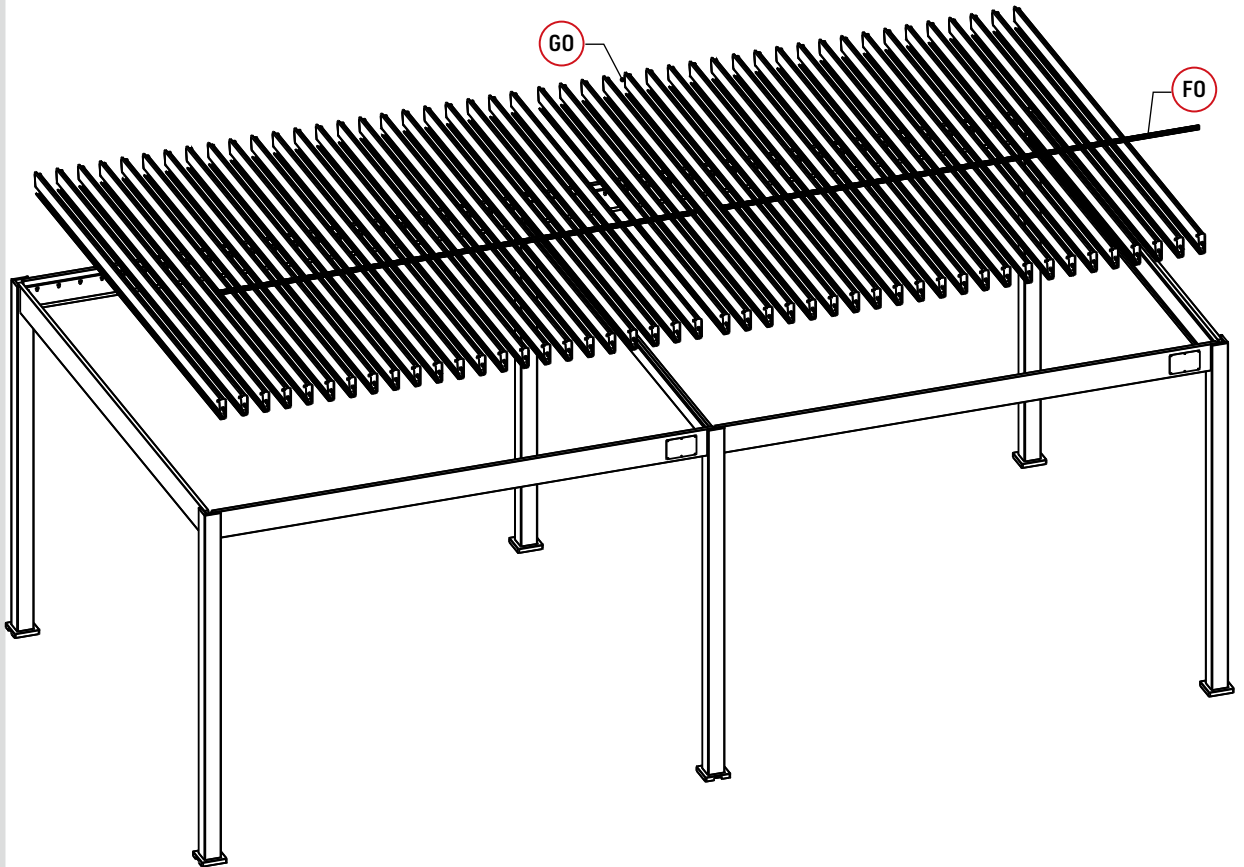

Befestigen Sie Gummistopfen an beiden Enden der Lamellen

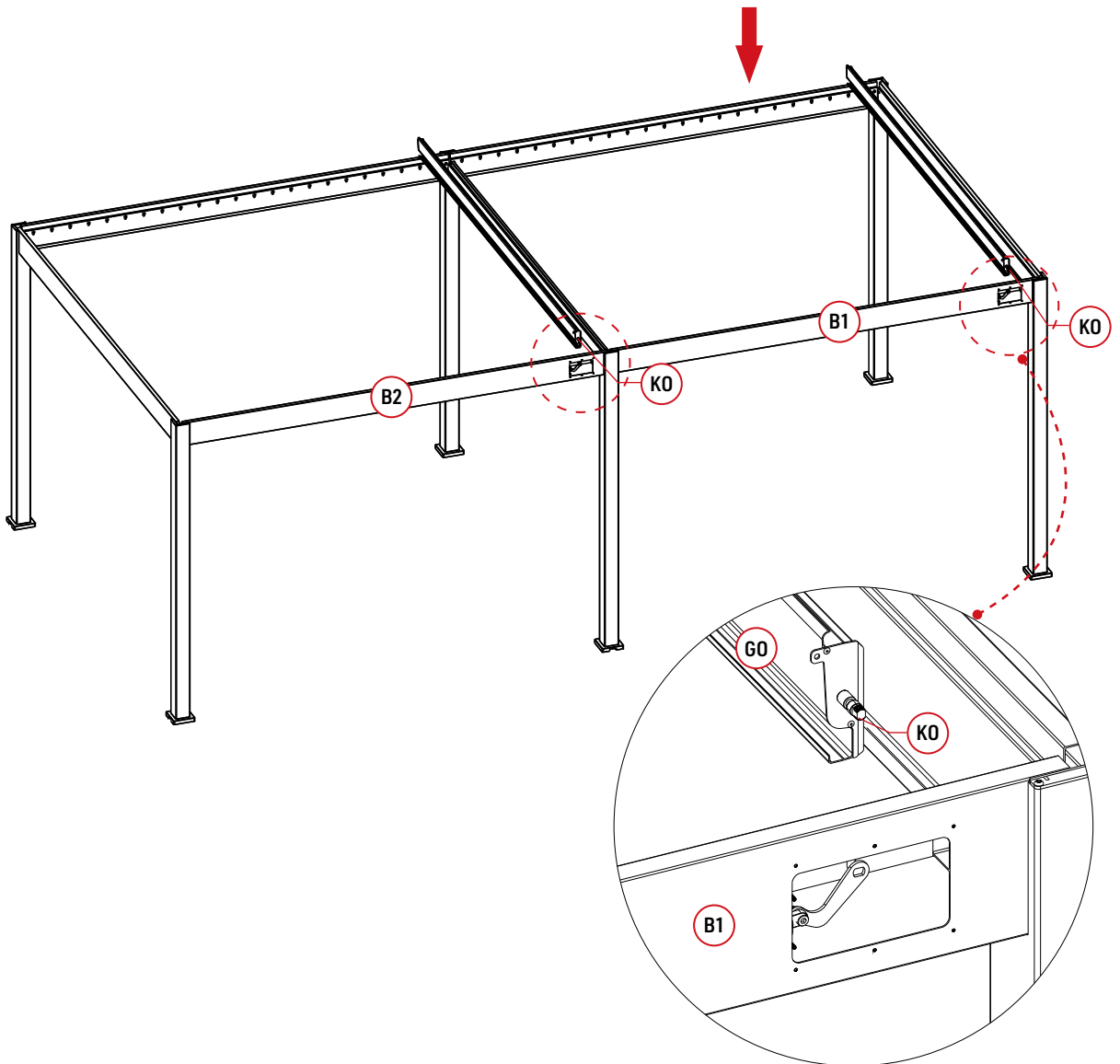

1

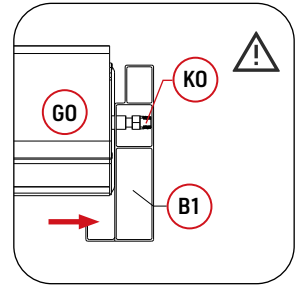
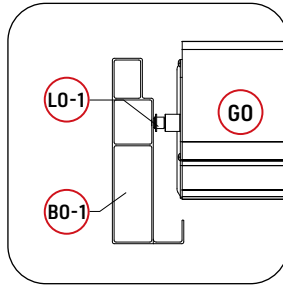
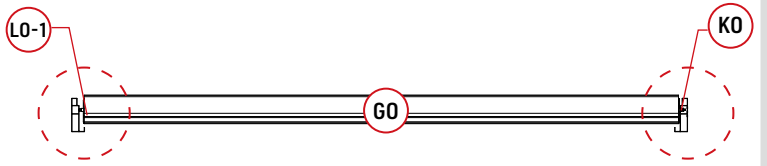
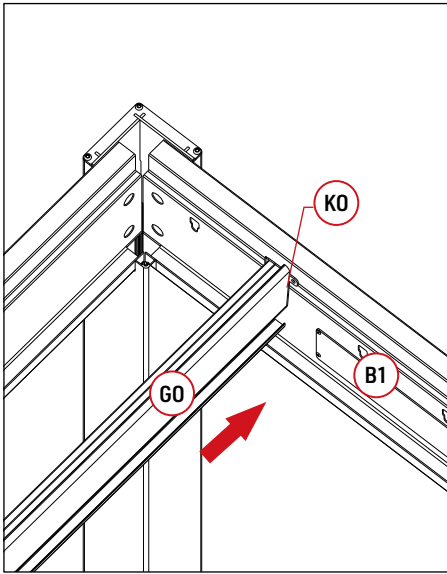

2

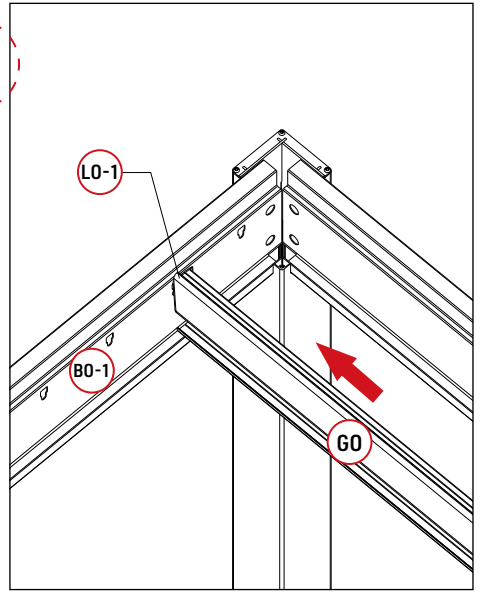
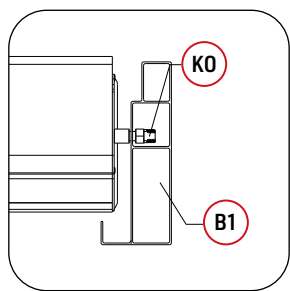
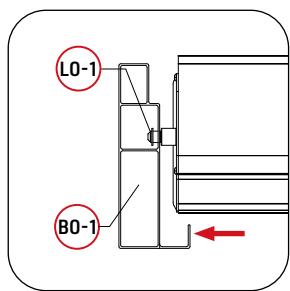
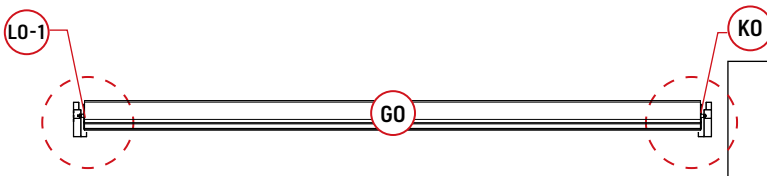

Teile

U0-3	 M14	2
------	---	---

Machen Sie die Lamellen flach und verbinden Sie dann den Motorkipphebel mit der Spindel.

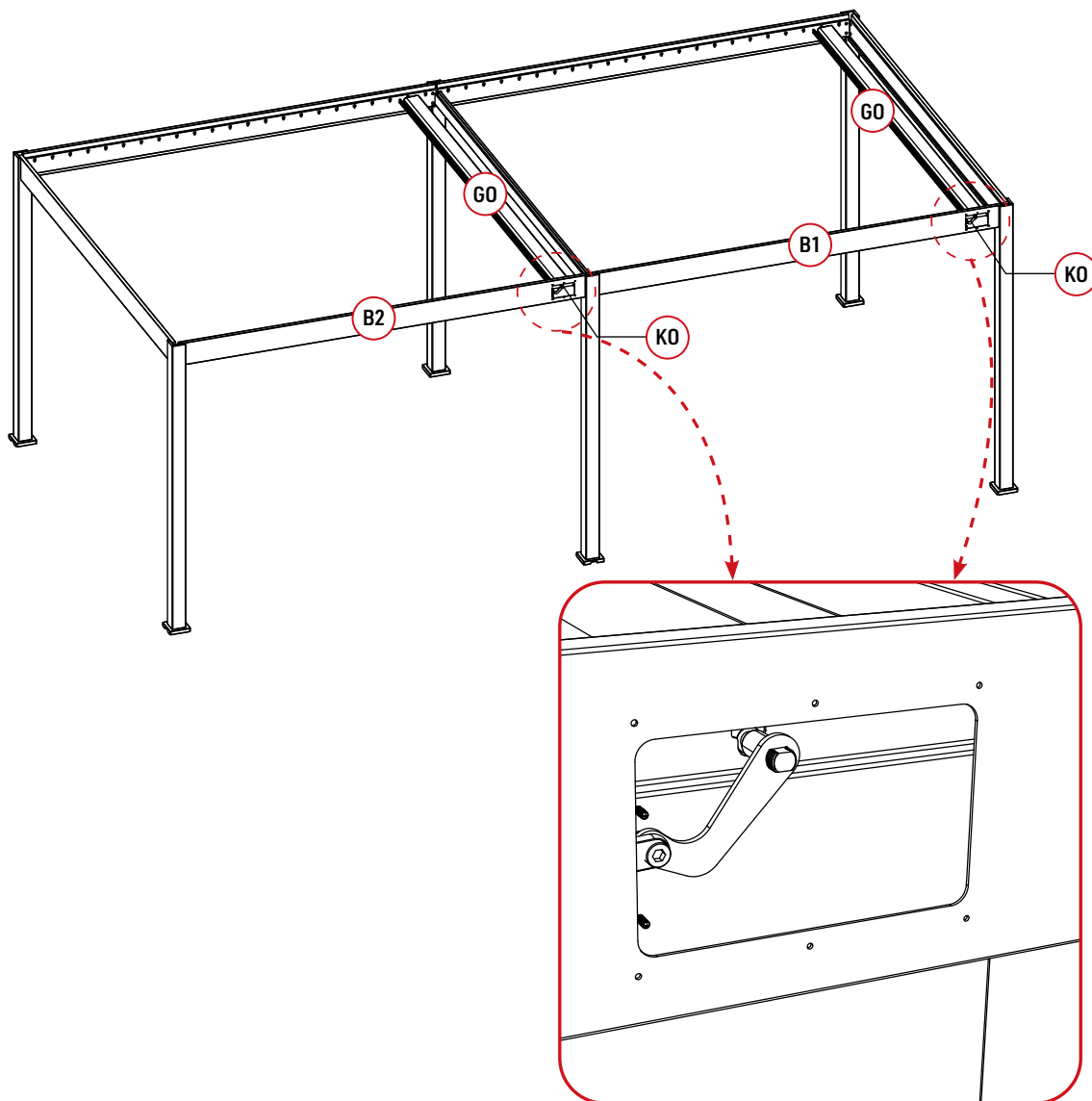

1.

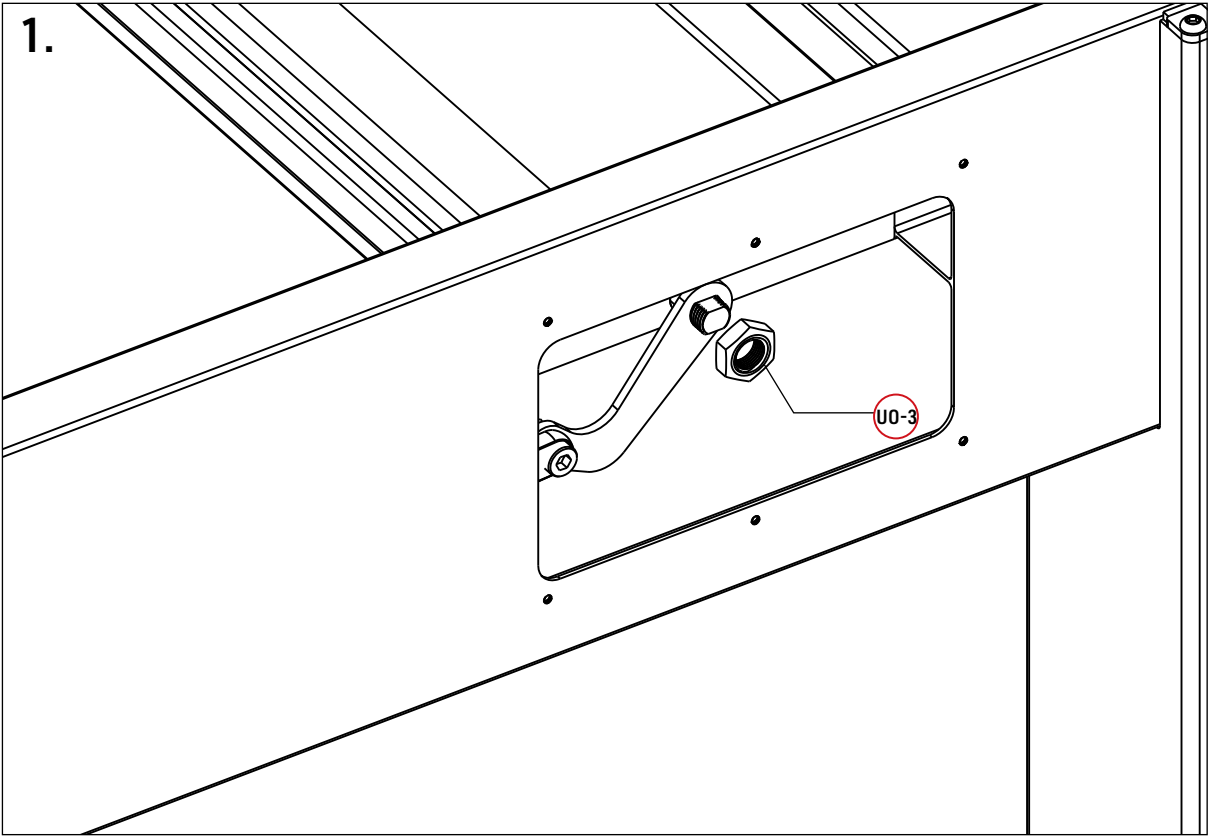

2.

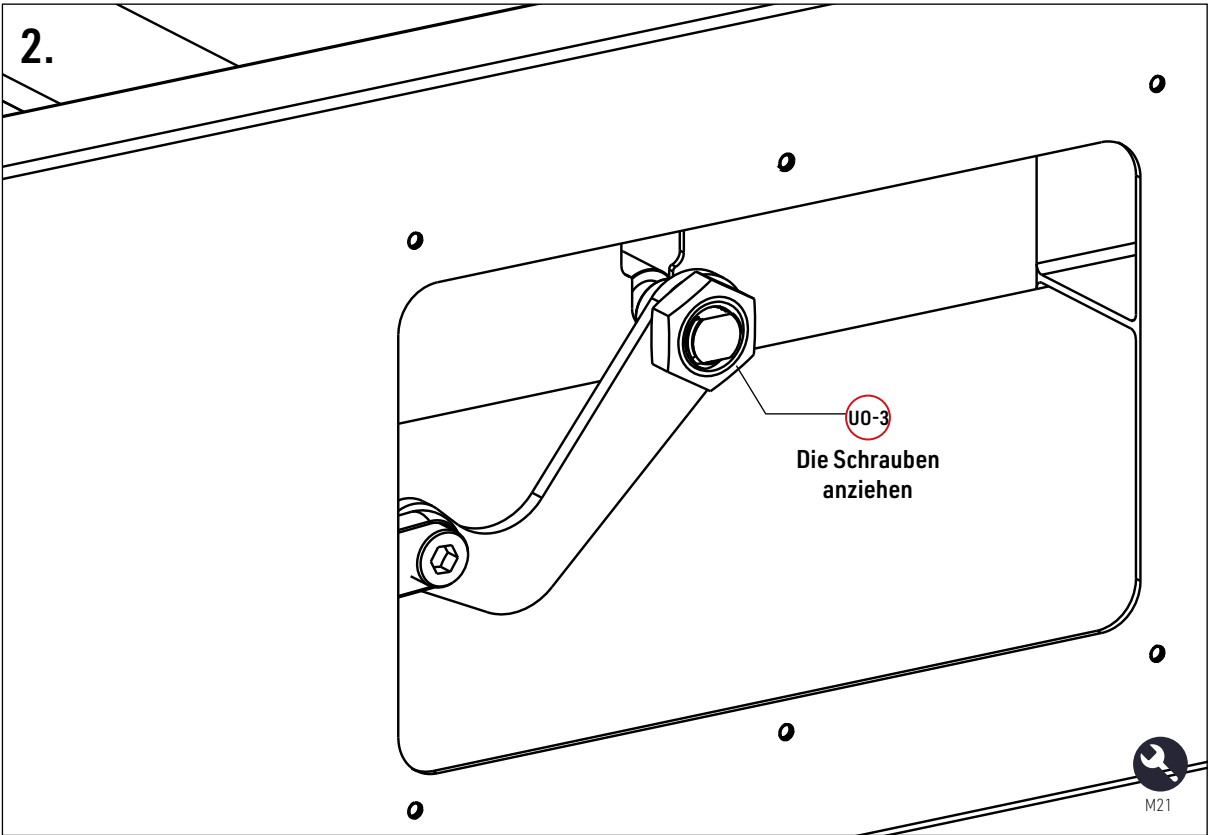

Ziehen Sie die E-P-Verlängerungsleitung wie im Diagramm unten gezeigt und verbinden Sie dann die Verlängerungsleitung mit der 1#-Leitung des E-C.

Verbinden Sie die 3#-Leitung des E-C mit dem Kabel des Motors

Verbinden Sie die Verlängerungsleitung (E-P1) mit der 4#-Leitung des E-C

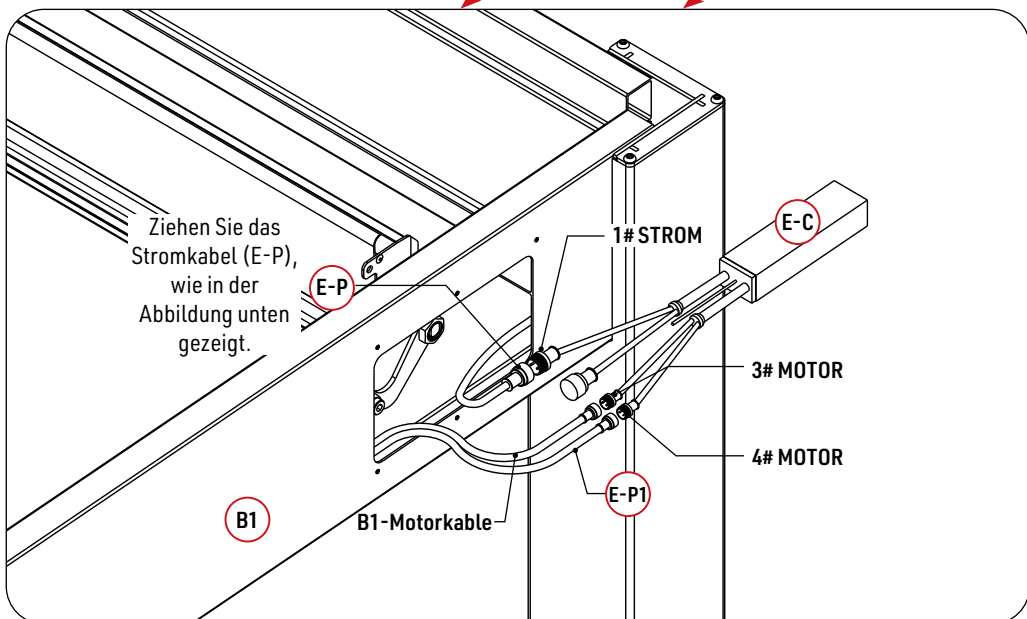
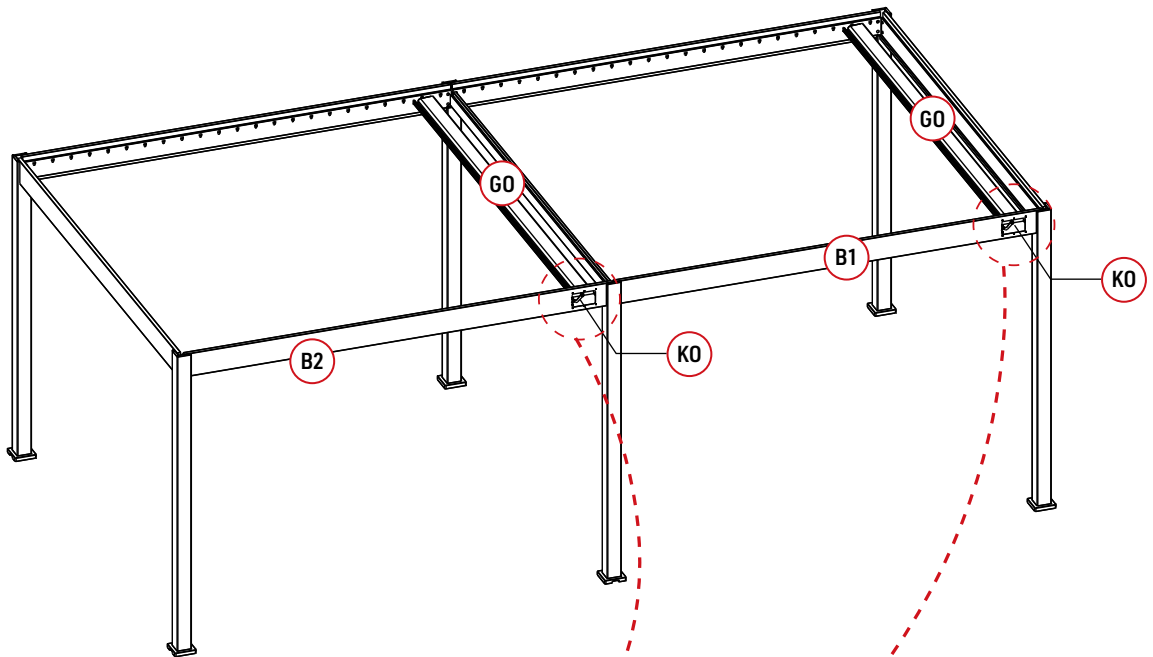

Den LED-Streifen in die Dachrinne einsetzen

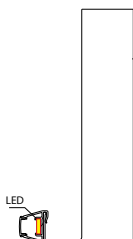

Stecken Sie die Ausgangsleitung des LED-Controllers (L-C1) in den Hohlraum des Pfostens

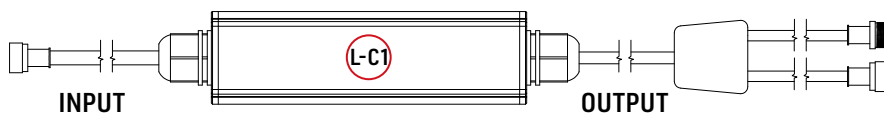

1.

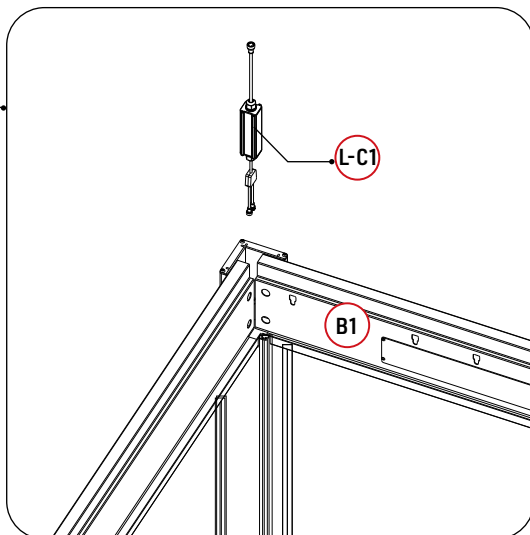
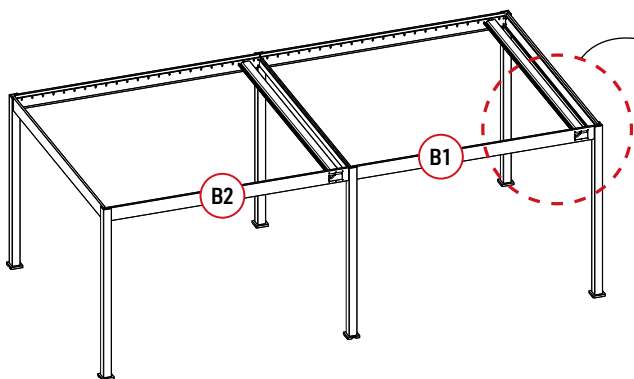

Bitte beachten Sie, dass das Eingangsende des LED-Controllers nach oben und das Ausgangsende nach unten zeigen sollte.

Ziehen Sie die beiden Kabel des Ausgangsendes mit der mitgelieferten Bürste aus der Ablaufkerbe.

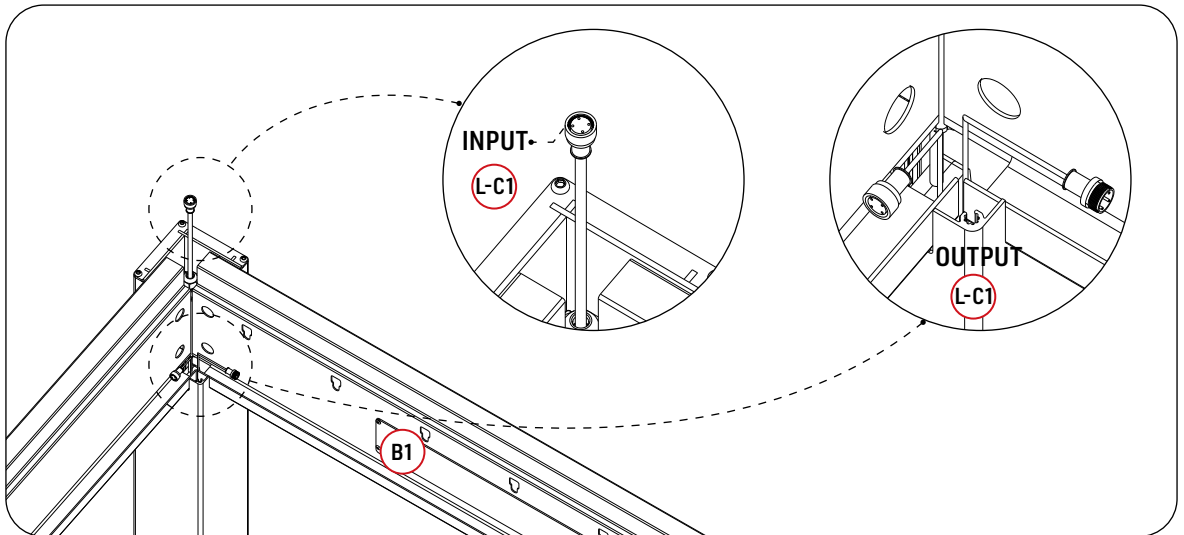

Verbinden Sie die Eingangsleitung des LED-Controllers (L-C1) mit dem 2# LED des Controllers (E-C).

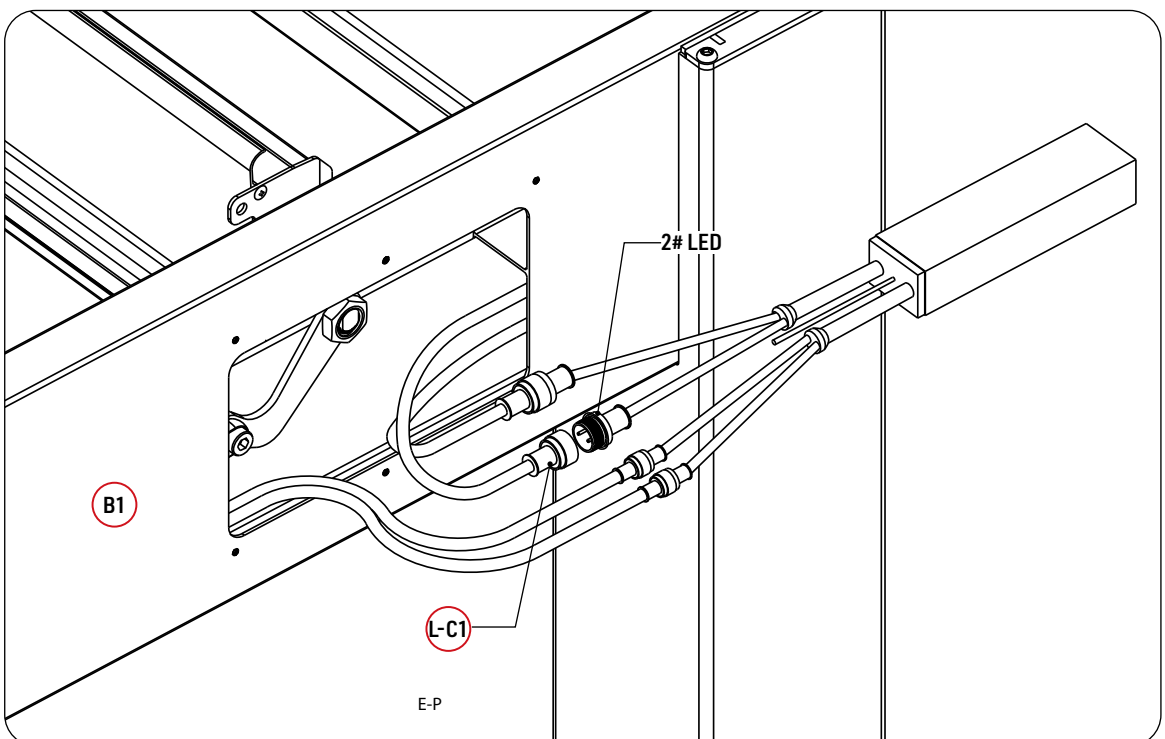

Installieren Sie alle LED-Streifen in Reihe und verbinden Sie dann die beiden Enden des LED-Streifens mit den beiden Ausgangsleitungen des LED-Controllers (L-C1).

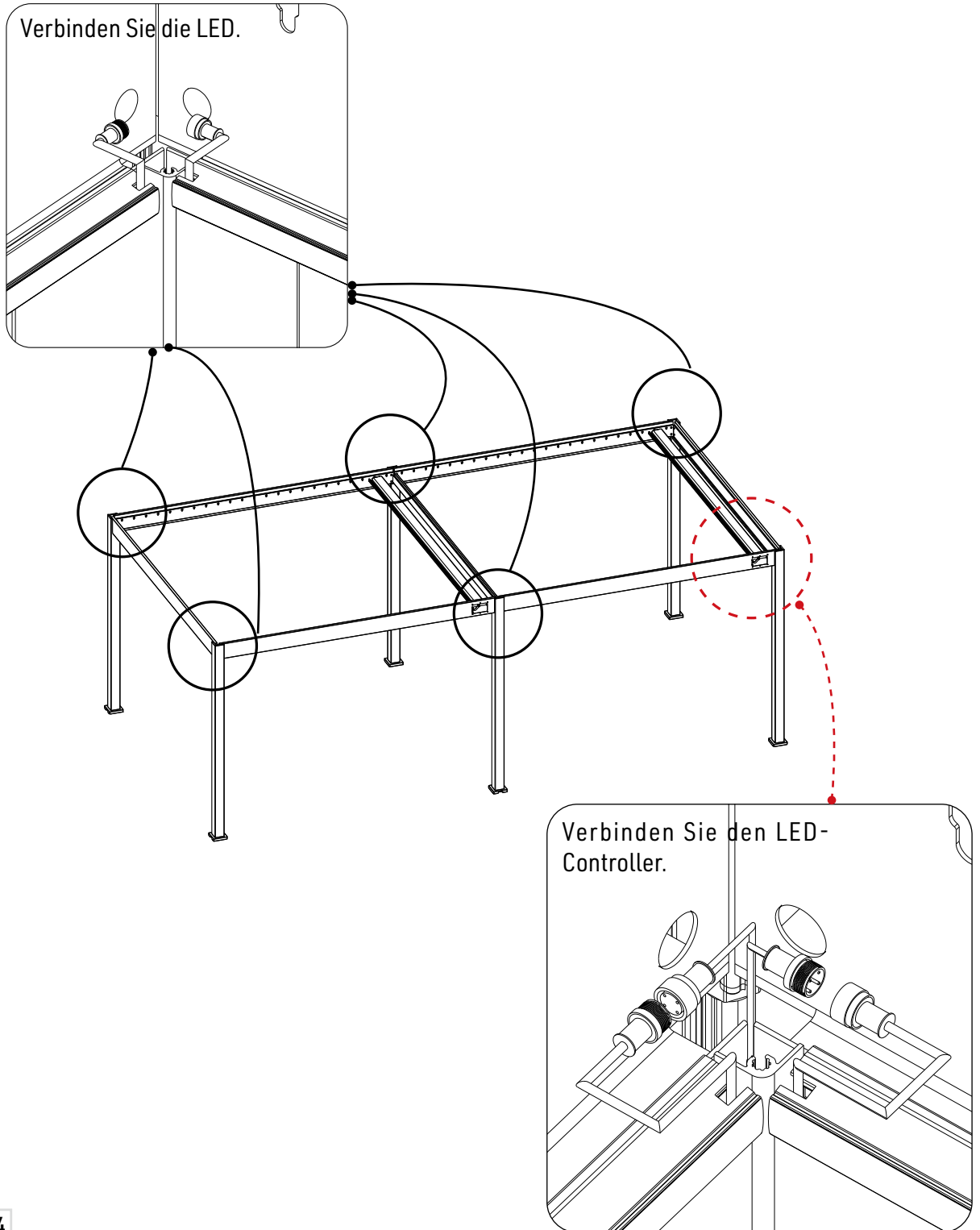

Schritt 3: Lamellen installieren & Anschluss

E-R		1
-----	---	---

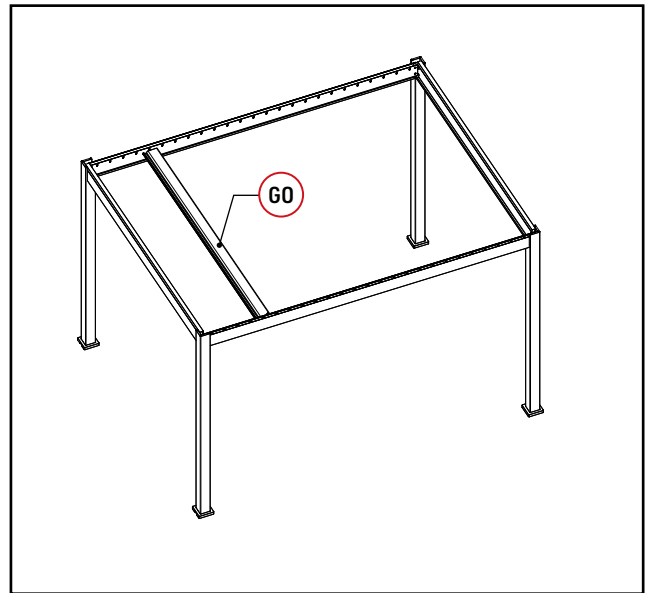

Motoranschluss



1. Drücken Sie die UP-Taste auf der Fernbedienung und halten Sie diese für 3-5 Sekunden gedrückt, bis die Kontrollleuchte dauerhaft leuchtet.
2. Halten Sie die Taste weiterhin gedrückt (wichtig).
3. Stecken Sie den Stromstecker ein, während Sie die UP-Taste weiterhin gedrückt halten. Wenn eine leichte Vibration an den Hauptlamellen spürbar ist, bedeutet dies, dass die Fernbedienung mit dem Motor gekoppelt wurde, und die Taste kann losgelassen werden.

Schritt 1

Drücken und halten Sie 3 Sekunden lang.

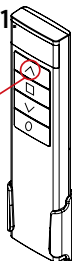

Licht

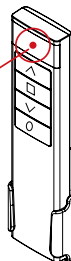

Schritt 2.

Stecken Sie den Stromstecker ein.

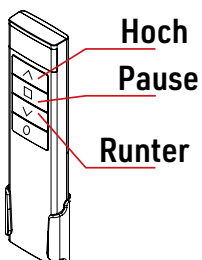
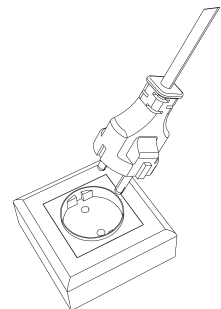

- Steuerung des An- und Ausschaltens der LED
- Steuerung der Drehung der Lamellen

Wenn Sie die LED-Farbe steuern möchten, laden Sie bitte unten abgebildete die App unten herunter.

Die LED-Farbsteuerung ist nur verfügbar, wenn Sie Zugriff auf WLAN haben



Tuya Smart

Tuya APP Netzwerk-Verbindung

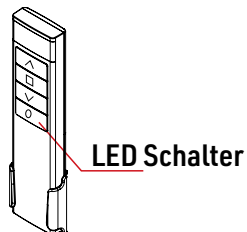

Wenn die LED beim Einschalten nicht verbunden werden kann, setzen Sie bitte den Controller der LED zurück.

Schalten Sie die LED 5 Mal hintereinander ein und aus.

Löschen Sie auch die vorherige Netzwerkverbindung. Wechseln Sie in den Smart Cong-Modus, die Ausgangs-LED blinkt dann 10 Mal.

Nachdem Sie alle Kabel angeschlossen und die LED-Leiste sowie die Lamellenrotation eingestellt haben, legen Sie den Controller (E-C) in den Hohlraum des Balkens (B1), wie in der Abbildung unten gezeigt. Um Schädigungen der Kabel zu vermeiden, stellen Sie bitte sicher, dass sich der Controller (E-C) sowie alle Kabel außerhalb des Bewegungsbereichs vom Motor-Schwingarm befinden.

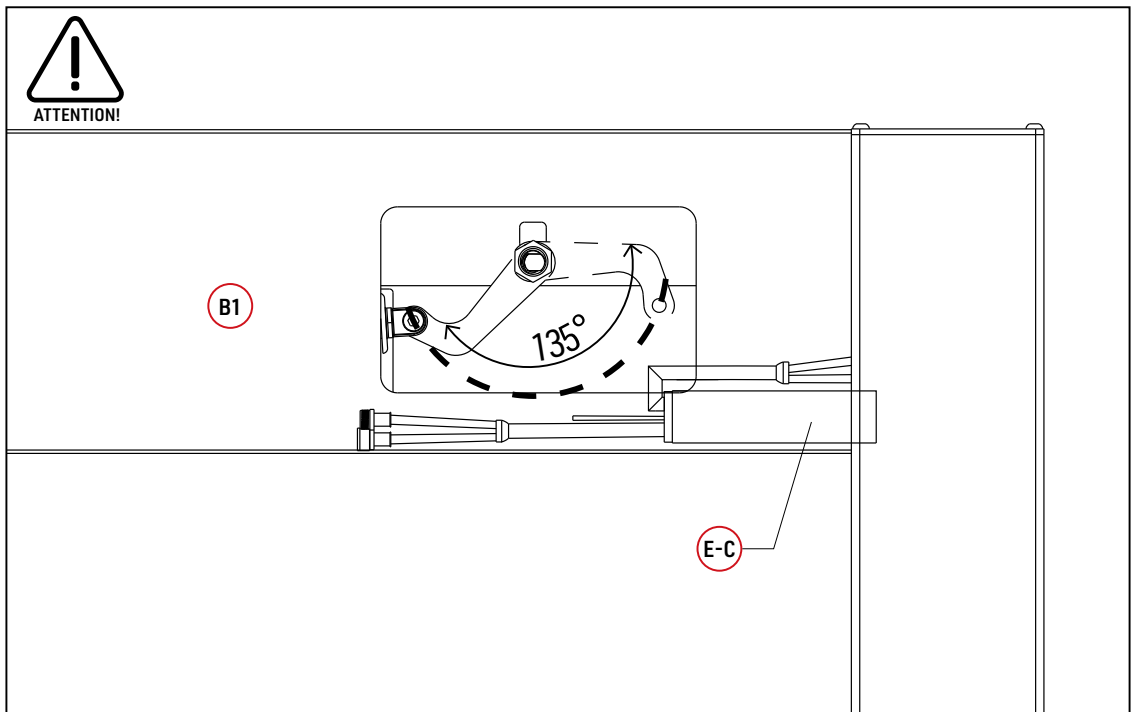

Teile

S0		92
----	---	----

1. Montieren Sie weitere Lamellen am Balken und machen Sie die Lamelle flach.
2. Decken Sie den Schraubenkopf mit Kunststoffkappen ab

1

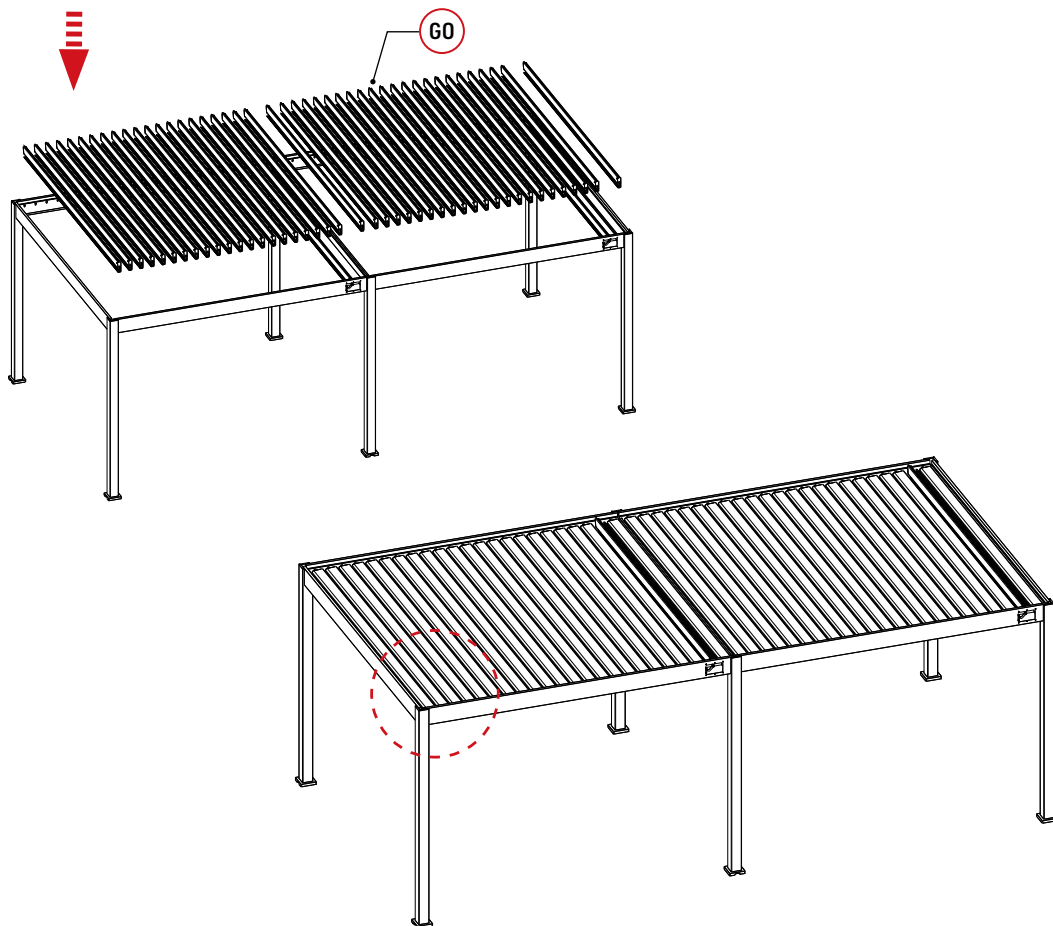



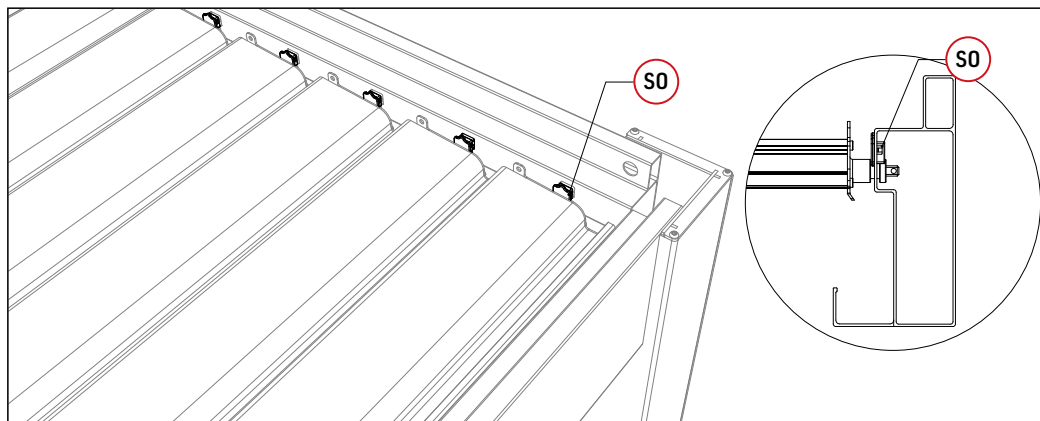

2



Schritt 3: Lamellen installieren & Anschluss 3-7

Teile

F0		2
X0-2		46
V0		138
U0		46
U0-1		46

Werkzeuge

Z0-1		1
Z0-2		1
Z0-5		1

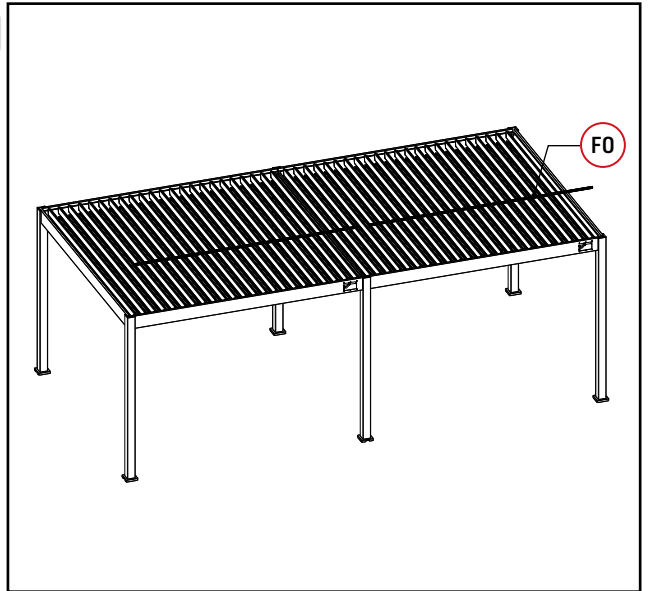

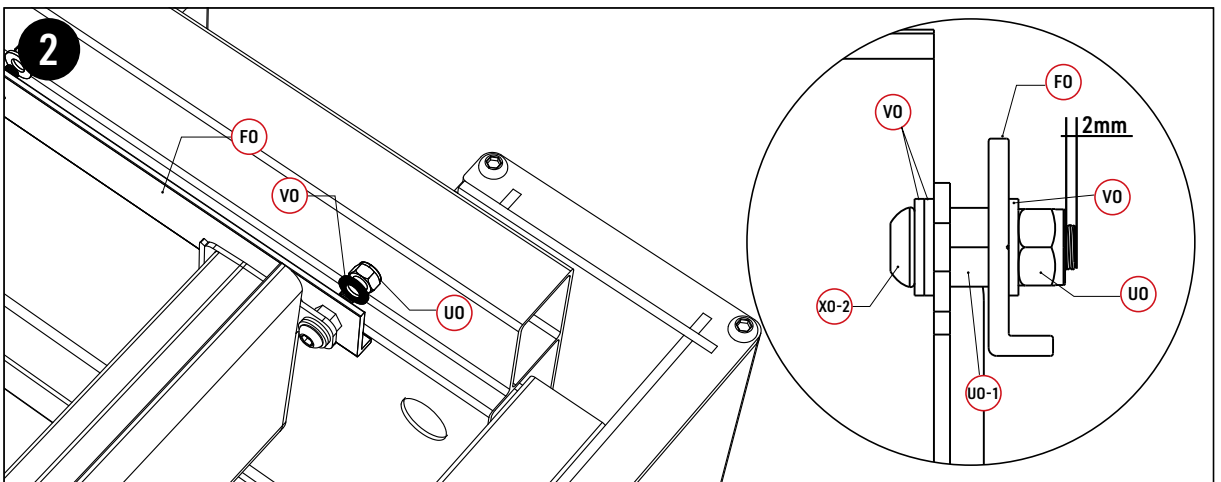
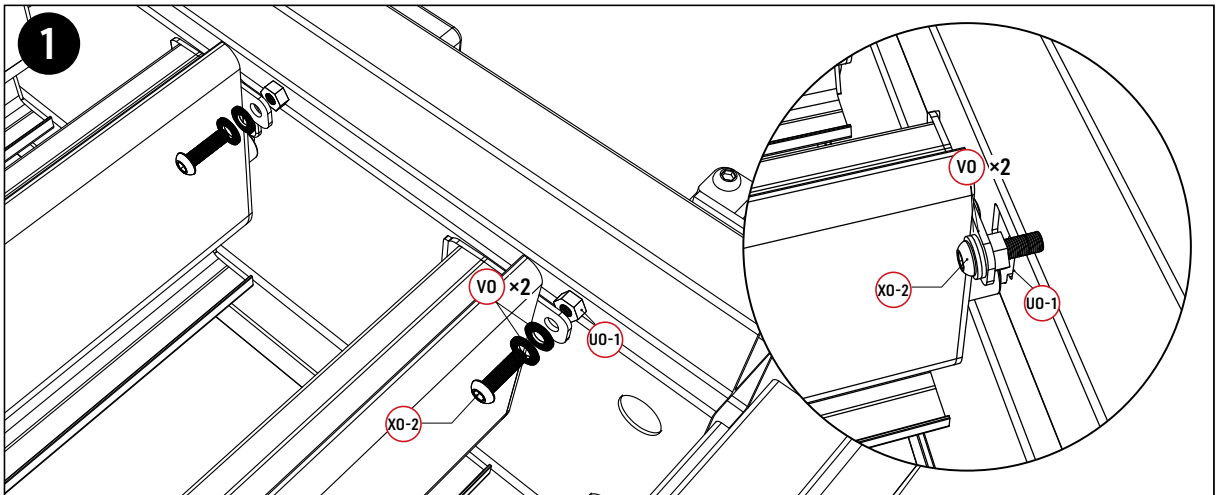

Installieren Sie den Verbindungsbalgen



Schritt 3: Lamellen installieren & Anschluss 3-8

Teile

RO		24
TO	 10x80	24

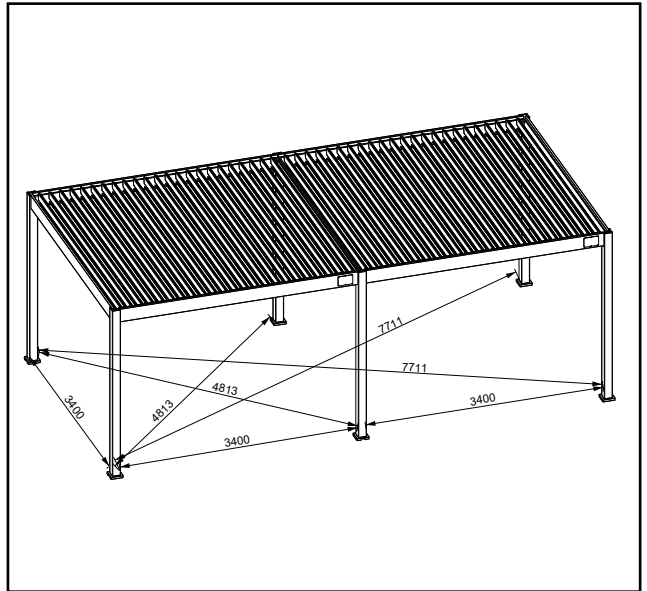

Decken Sie den Schraubenkopf mit Kunststoffkappen ab

1

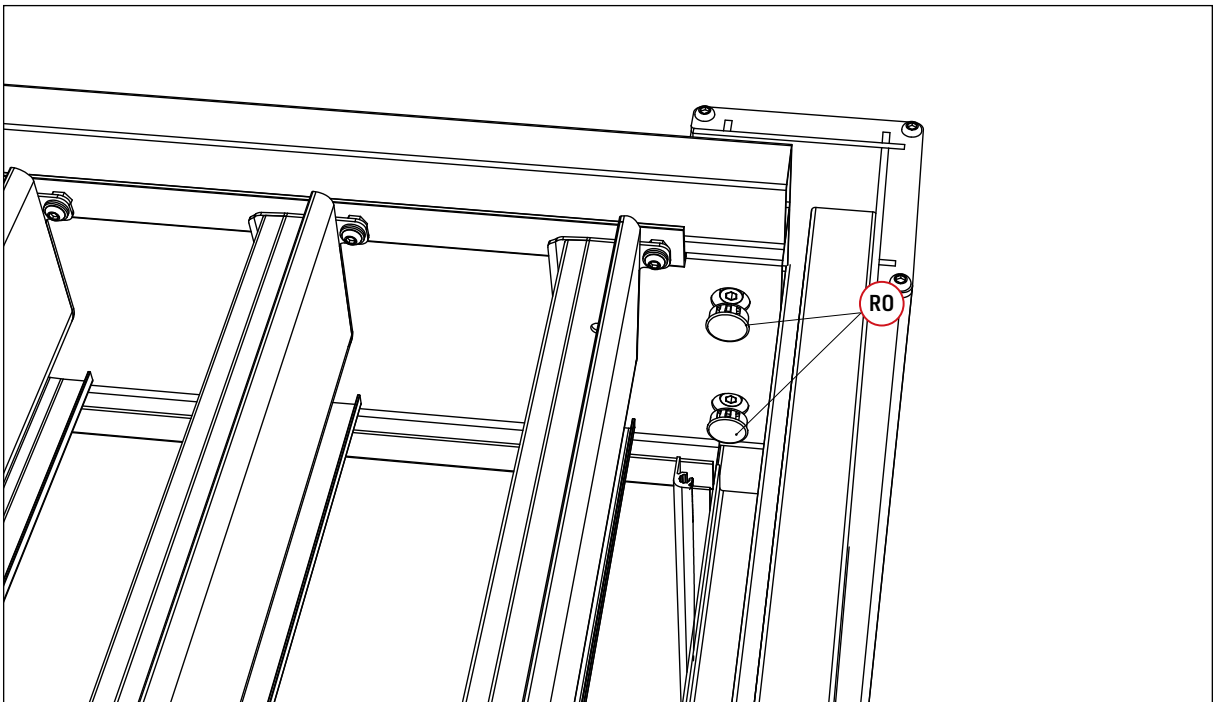

2

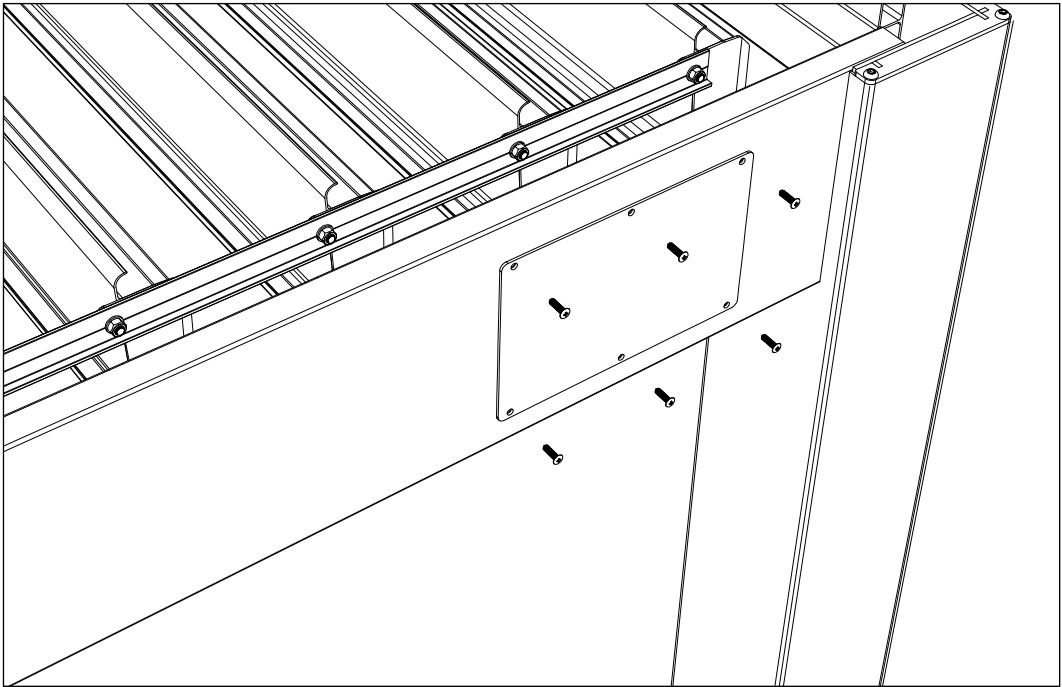

3



Bitte überprüfen Sie, ob alle Fundamentmaße korrekt sind, und befestigen Sie dann alle Grundplatten.

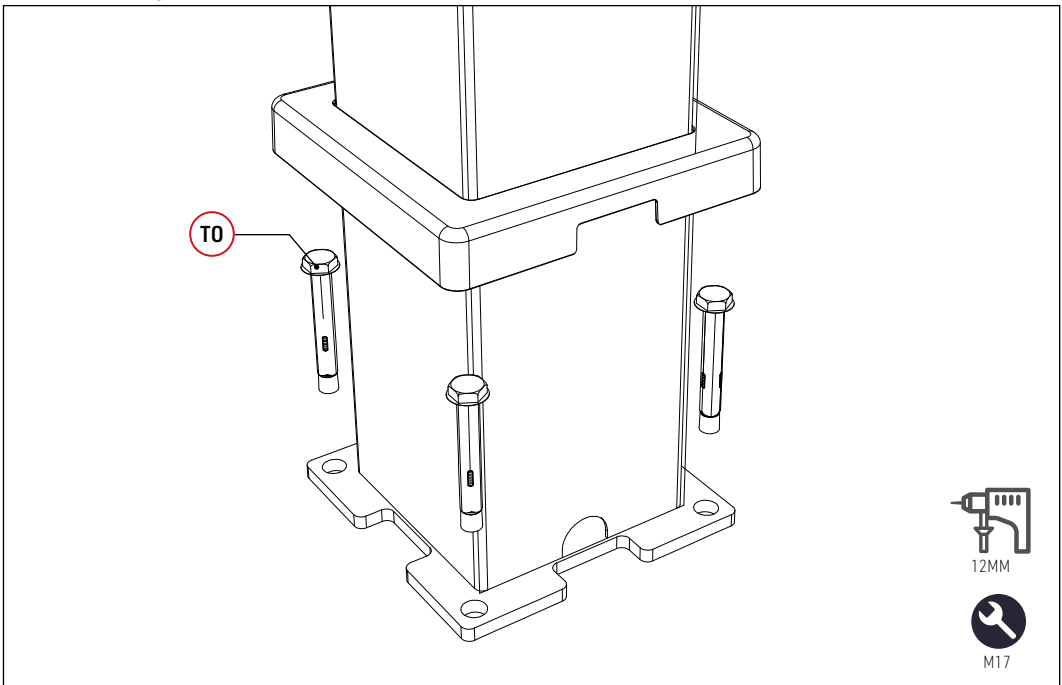

Kabelinstallation Montageanleitung

Elektrisch+LED

Plug-in

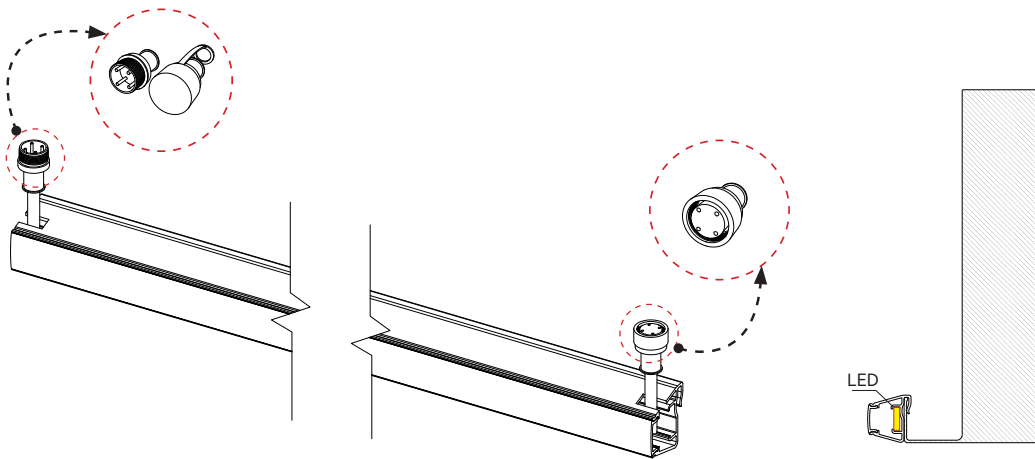

Referenz	Teile	Menge
L-C1	 LED Controller	1

FÜR LED



Den Anschluss der elektrischen Steuerung entnehmen Sie bitte der Montageanleitung der elektrischen Pergola

im Innenraum des horizontalen Balkens platziert

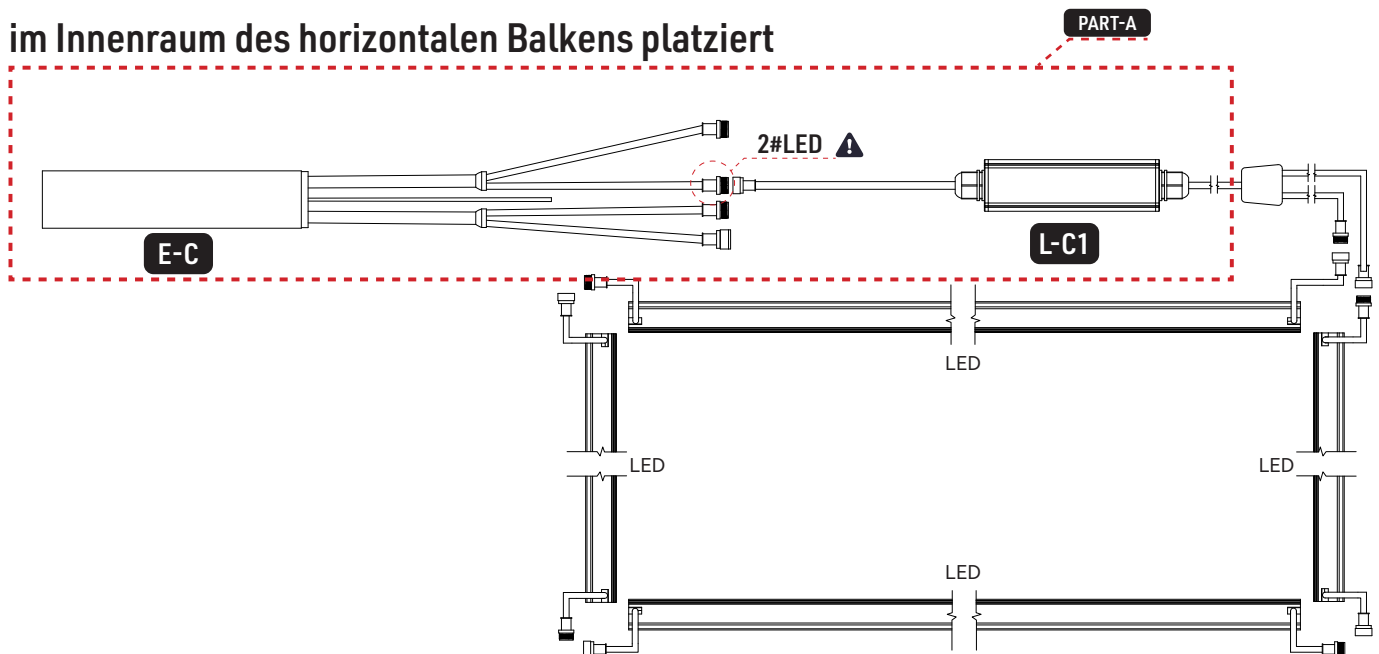



Bitte beachten Sie die Installationsanleitung der motorisierten Pergola und stellen Sie sicher, dass der Transformator und der Stecker korrekt positioniert sind.

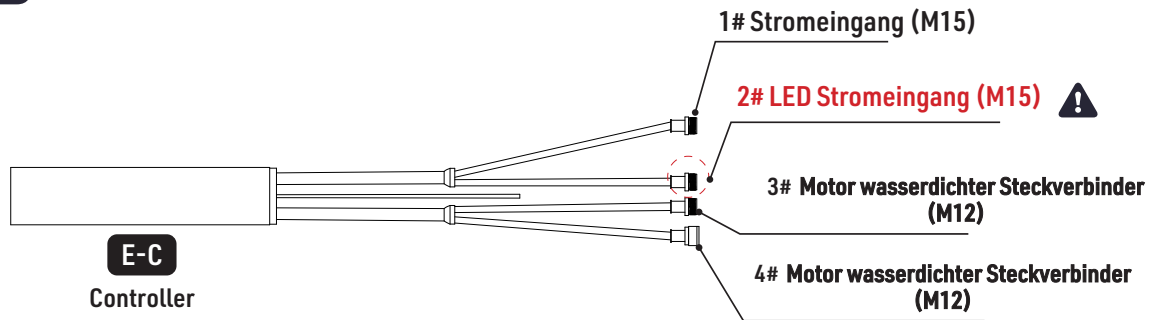

Schließen Sie zuerst den LED-Controller an den Transformator (TEIL-A) an und platzieren Sie ihn dann in der Aussparung des Balkens.

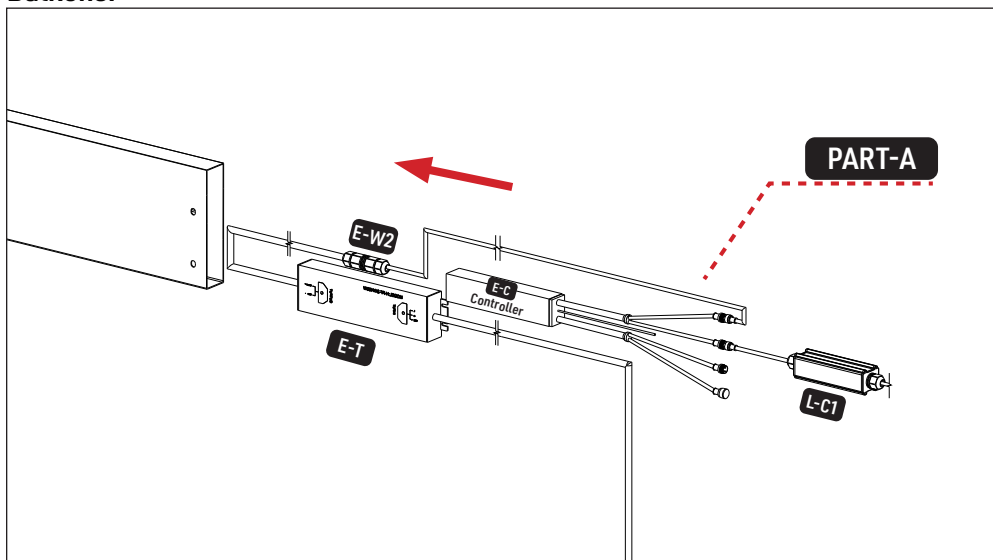

Das Kabel des Transformators verläuft durch den Pfosten und das Kabel tritt aus dem Ablauf aus. "EINGANG" verbinden Sie mit der Hausstromversorgung, "AUSGANG" verbinden Sie mit der LED.

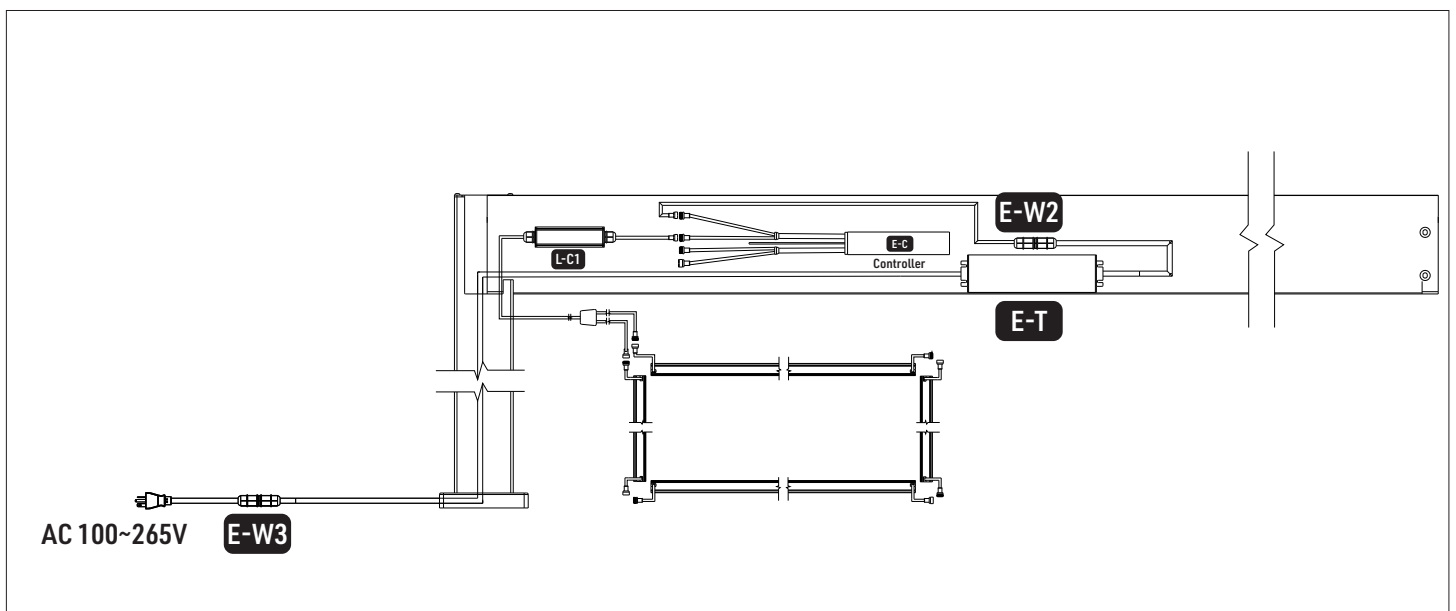

Tuya APP Netzwerkverbindung

Bitte laden Sie die entsprechende Tuya Smart/Smart Life App gemäß Ihrer Region herunter. Drücken und halten Sie die Match/Set-Taste für 2 Sekunden oder drücken Sie die Match/Set-Taste zweimal schnell hintereinander.

Löschen Sie die vorherige Netzwerkverbindung, geben Sie den Smart Config-Modus ein, die lila LED-Anzeige blinkt schnell, die Ausgangs-LED blinkt 10 Mal.

Wiederholen Sie das Ein- und Ausschalten 5 Mal hintereinander,

löschen Sie ebenfalls die vorherige Netzwerkverbindung, geben Sie den Smart Config-Modus ein, die Ausgangs-LED blinkt 10 Mal.

Wenn die Tuya APP Netzwerkverbindung erfolgreich ist, hört die RUN LED-Anzeige auf, lila zu blinken, und ändert sich zu rot. In der Tuya APP können Sie das RGB-Gerät finden.



Smart life APP



Tuya Smart

Tuya APP Schnittstelle

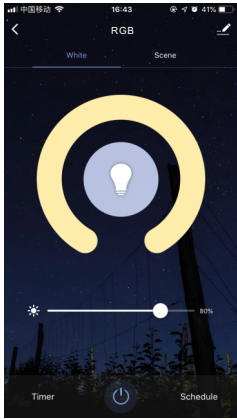

Weiß Schnittstelle

Berühren Sie den Helligkeitsschieberegler, erhalten Sie zuerst ein Rad von weißer Farbe und passen Sie dann die Helligkeit an.

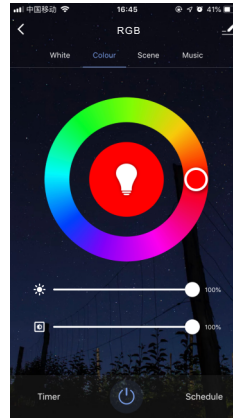

Farbschnittstelle

Berühren Sie das Farbrad, um die statische RGB-Farbe anzupassen. Berühren Sie den Helligkeitsschieberegler, um die Farbhelligkeit anzupassen. Berühren Sie den Sättigungsschieberegler, um die Farbsättigung anzupassen, nämlich den Übergang von der aktuellen Farbe zu Weiß (gemischtes RGB).

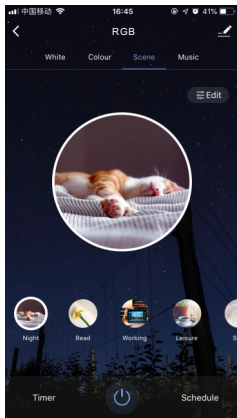

Szenen-Schnittstelle

Die Szenen 1-4 sind eine statische Farbe für alle Lichttypen. Die innere Farbe dieser Szenen kann bearbeitet werden.

Die Szenen 5-8 sind dynamische Modi, wie z.B. Grün einblenden und ausblenden, RGB-Sprung, 6 Farbsprung, 6 Farbverlauf.

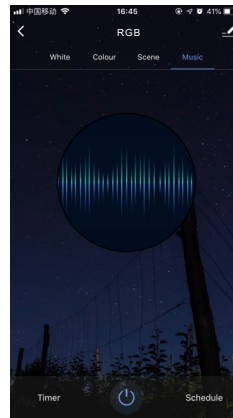

Musik, Timer, Zeitplan

Die Musikwiedergabe kann den Musikplayer des Smartphones oder das Mikrofon als Musiksignal-Eingang verwenden.

Die Timer-Taste kann das Licht in den nächsten 24 Stunden ein- oder ausschalten.

Die Zeitplan-Taste kann mehrere Timer hinzufügen, um das Licht zu verschiedenen Zeitpunkten ein- oder auszuschalten.

Fernbedienung anlernen (Optional)

Der Endbenutzer kann die passenden Anlern-/Löschmethoden wählen. Zwei Optionen stehen zur Auswahl:

Verwenden Sie die Match-Taste

Anlernen:

Kurzes Drücken der Match-Taste, anschließend sofort die Ein/Aus-Taste (Einzonen-Fernbedienung) oder die Zonentaste (Mehrzonen-Fernbedienung) auf der Fernbedienung drücken.
Das schnelle Blinken der LED-Anzeige einige Male bedeutet, dass das Anlernen erfolgreich war.

Löschen:

Drücken und halten Sie die Match-Taste für 20 Sekunden, Das schnelle Blinken der LED-Anzeige einige Male bedeutet, dass alle angelernten Fernbedienungen gelöscht wurden.

Verwenden Sie den Power-Neustart

Anlernen:

Schalten Sie die Stromversorgung aus, schalten Sie dann die Stromversorgung wieder ein und wiederholen Sie dies. Drücken Sie sofort dreimal kurz die Ein/Aus-Taste (Einzonen-Fernbedienung) oder die Zonentaste (Mehrzonen-Fernbedienung) auf der Fernbedienung.
Das Licht blinkt 3 Mal, was bedeutet, dass das Anlernen erfolgreich war.

Löschen:

Schalten Sie die Stromversorgung aus, schalten Sie dann die Stromversorgung wieder ein, und wiederholen Sie dies. Drücken Sie sofort fünfmal kurz die Ein/Aus-Taste (Einzonen-Fernbedienung) oder die Zonentaste (Mehrzonen-Fernbedienung) auf der Fernbedienung.
Das Licht blinkt 5 Mal, was bedeutet, dass alle angelernten Fernbedienungen gelöscht wurden.

Dynamik-Modus Liste

No.	Name	No.	Name
1	RGB-Sprung	6	RGB ein- und ausblenden
2	RGB-Verlauf	7	Rot ein- und ausblenden
3	6-Farben-Sprung	8	Grün ein- und ausblenden
4	6-Farben-Verlauf	9	Blau ein- und ausblenden
5	Gelb, Cyan, Lila Verlauf	10	Weiß ein- und ausblenden

Installationsvorsichtsmaßnahmen

1. Die Produkte sollten nicht gestapelt werden, der Abstand sollte ≥ 20 cm betragen, um die Lebensdauer der Produkte durch schlechte Wärmeableitung nicht zu beeinträchtigen.
2. Das Produkt sollte nicht in der Nähe des Schaltnetzteils installiert werden, mit einem Abstand von ≥ 20 cm, um Strahlungsstörungen des Schaltnetzteils zu vermeiden.
3. Die Installationshöhe sollte ≥ 1 m vom Boden betragen, um zu verhindern, dass die Fernbedienungsdistanz aufgrund eines zu schwachen Empfangssignals verkürzt wird.
4. Die Produkte dürfen sich nicht in der Nähe von oder unter metallischen Gegenständen befinden - mit einem Abstand von ≥ 20 cm, um Signalabschwächung zu vermeiden und die Fernbedienungsreichweite zu verkürzen.
5. Vermeiden Sie die Installation an der Ecke der Wand oder der Ecke des Balkens, mit einem Abstand von ≥ 20 cm, um Signalstörungen zu vermeiden.

3,6x7,2 meter Pergola Electric, Aluminum, LED

Assembly Instructions - EN

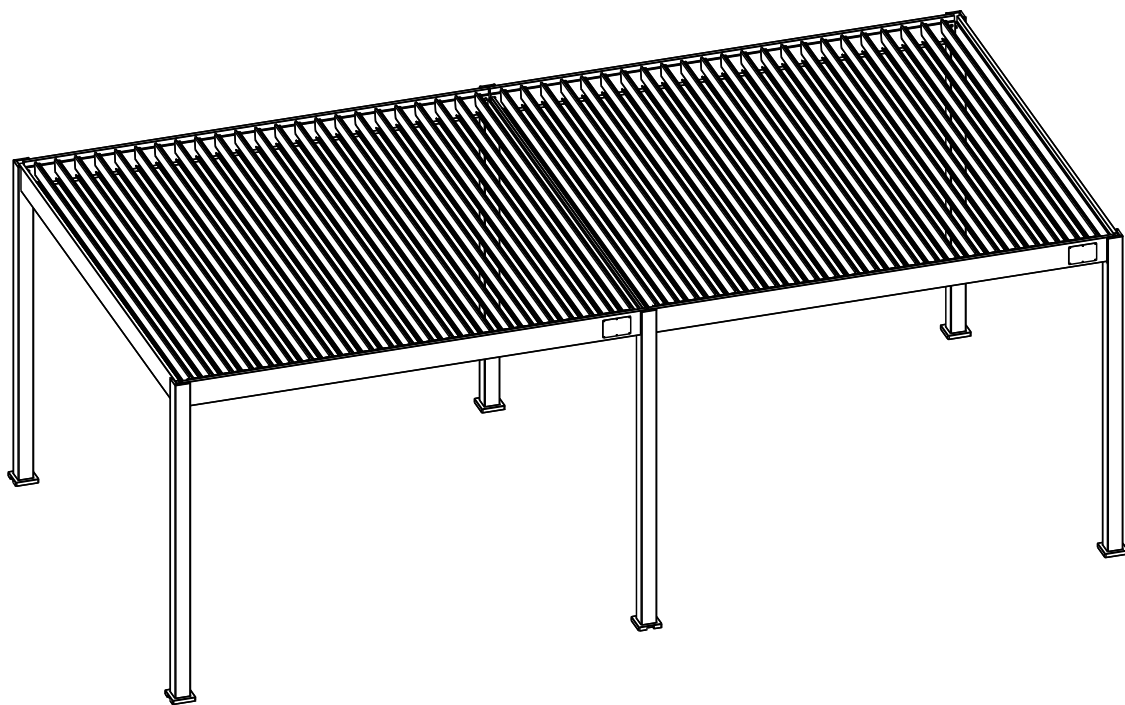

E-Deluxe Plus Aluminum Pergola 3,6×7,2 meter

These instructions have to be saved during the whole product life cycle. We advise you to read these very carefully before proceeding to the assembly. The user will be reliable for any damages or injuries caused due to incorrect or improper installation.

NECESSARY TOOLS AND SAFETY GEAR (NOT SUPPLIED)

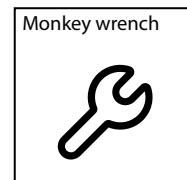
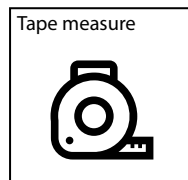
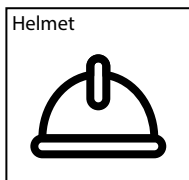
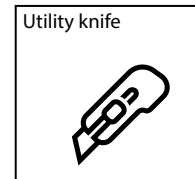
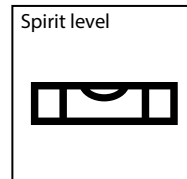
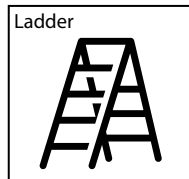

2D FOOTING MEASUREMENT (dimensions in mm)

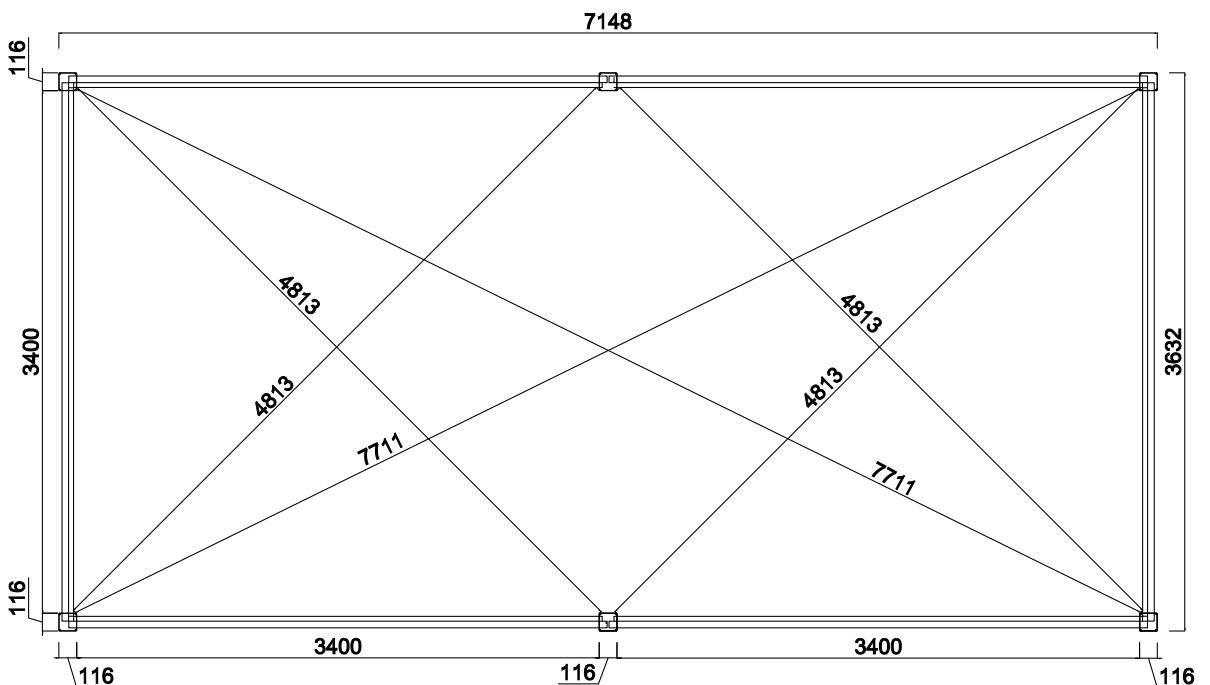

3D FOOTING MEASUREMENT (dimensions in mm)

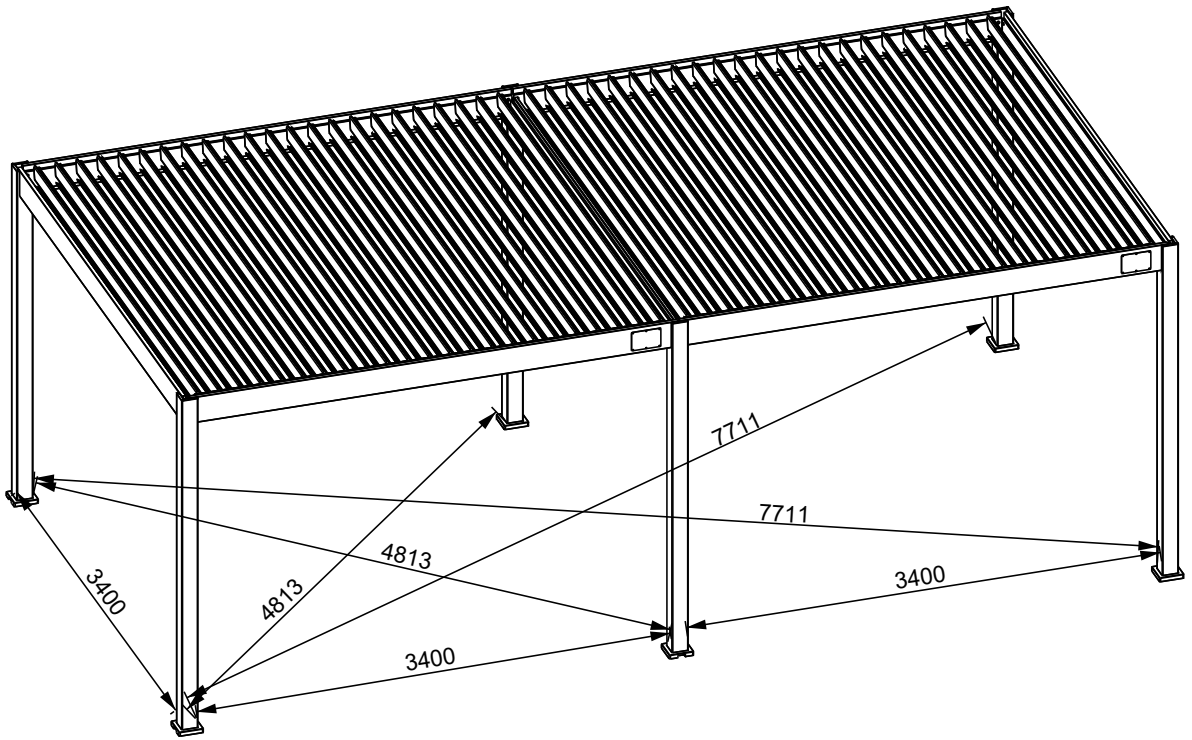

PRECAUTION OF USE

This product should not be used in extreme weather: storms, violent winds, hail, and snow. We guarantee the resistance of the pergola for winds up to 88 km/h and a maximum snow weight of 50kg/m².

As in the case of strong winds or snow, we highly recommend leaving the louvers open. To maintain good working conditions of your louvers, please clear any snow on them.

Our pergola can withstand heavy rain, but we cannot guarantee it will be 100% waterproof due to some extreme weather conditions.

Exceptional climatic events may compromise the perfect sealing of the product.

To avoid any damages and injuries, we do not recommend climbing on the roof or the structure of the pergola.

TIPS AND SAFETY INSTRUCTIONS

Depending on the location and surface area, construction may be subject to building permits. Make sure you have checked with your local authorities to obtain the needed information before the assembly.

Product assembly :

- At least 2/3 people required
- Remove protective film (around 1 hour needed)
- Do not keep children near the assembly area
- Beware of the risk of pinching
- Do not tighten the screws before assembling the whole product
- All assembly steps must be carefully followed
- Check the level of the structure on all sides
- Do not anchor the pergola before assembling the whole product

No changes can be made to the product. Products tampered with by the user are not covered by the warranty, thus being declared as void.

The location should be chosen carefully. It is recommended to avoid mounting your pergola on a rainy day, facing the prevailing winds, and under an overhanging tree.

The pergola must be mounted on a flat-level foundation. It is recommended to install it on a concrete slab or 25x25 cm concrete pads at each post. Please, anchor the pergola properly to the ground using expansion screw.

If you would like to mount your pergola near your house or a building, please check the presence of gutters for water drainage.

Should these instructions not be followed or only partially, the warranty will be voided by the seller.

MAINTENANCE

Regular maintenance is necessary to ensure its longevity and aesthetic appearance.

We recommend to :

- Clean your pergola once or twice a year with fresh water using a sponge or cloth.
- Do not use detergent or an abrasive material.
- Check the tightness of the screws regularly (at least once a year).
- Oil fastening regularly (at least once a year).
- Make sure that nothing hinders the water flow in the gutters (leaves, branches...).
- Remove any water that might stagnate around the legs of the pergola (lift the posts skirts).

WARRANTY

This warranty does not cover :

- Normal wear and tear inherent from the products.
- Loss or breakage of any part during unpacking or installation.
- Lack of care, neglect, vandalism, impact with foreign body, force, contact with a abrasives material, product aesthetics, disassembly, rebuilding or relocation.
- Force majeure: hail, high winds, storms, snow, floods, lightning etc...
- Product tampered with by the user.

The warranty only takes in account the replacement of spare parts or the provided product, no refund will be issued.

All warranty claims must be made at the sales outlet (store or website) where the product has been purchased.

PARTS LISTS (PER CARTON)

Before proceeding with the assembly of your louvered pergola, it is necessary to check that all parts listed are supplied and not damaged.







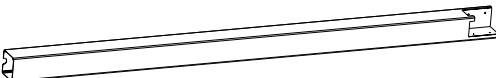
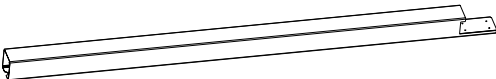

Any missing part must be reported within 10 days of delivery.



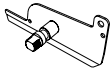
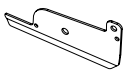
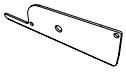

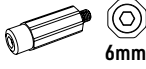





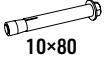





You can either go through your local outlet store or make the request directly on our website.





Do not discard the packaging without ensuring that the product is functioning properly.



CARTON 1/7 (POSTS AND LOOSE PARTS)

Reference	Parts	Quantity
A0		4
A0-1		2

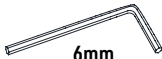



Reference	Parts	Quantity
I0		6
J0		6
K0		2
L0		44
L0-1		46
M0		90
M0-1		90
Q0		24
EO-1		2
RO		24
SO		92

Reference	Parts	Quantity	
T0	 10x80	24	
U0	 lock nut	136	
U0-1	 plastic nut	46	
U0-3	 M14	2	
V0		228	
W0	 4x16	 PH2	184
W0-1	 5x19	 5mm	6
X0	 6x40	 4mm	90
X0-1	 6x35	 4mm	24
X0-2	 6x20	 4mm	46
X0-3	 6x16	 4mm	4



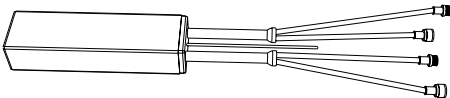

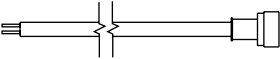
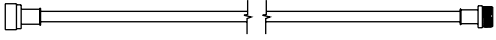
Reference	Parts	Quantity
ZO-1	 4mm	1
ZO-2	 4mm	1
ZO-3	 6mm	1
ZO-4	 6mm	1

Reference	Parts	Quantity
ZO-5	 10mm	1
ZO-6	 PH2	1
ZO-7		1

Electrical products

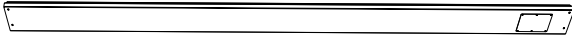
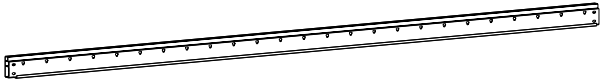
Reference	Parts	Quantity
E-C	Controller 	1
E-R	Remote control 	1
E-P	Power cable(M15) 	1
E-P1	Motor connection cable(M12) 	1
E-W2	Waterproof joint(2) 	1
E-W3	Waterproof joint(3) 	1

CARTON 2/7(BEAMS)

Reference	Parts	Quantity
B1	 *Motor inside	2
BO-1		2
CO		2
CO-1		2
FO		1



ATTENTION!

Connecting Bar(FO) & Brush Inside!

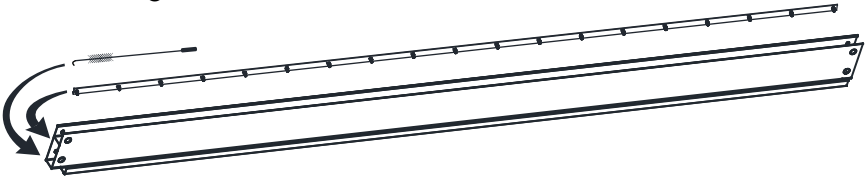

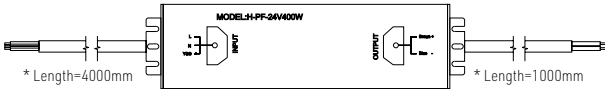

Electrical products

E-T	 <p>* Length=4000mm * Length=1000mm</p> <p>Transformer</p>	1
-----	--	---

CARTON 2/7 (BEAMS)

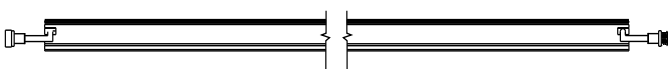
LED products

Reference	Parts	Quantity
LED1		6
L-B		1

CARTON 3/7 (LOUVERS)

Reference	Parts	Quantity
GO		9

CARTON 4/7 (LOUVERS)

Reference	Parts	Quantity
GO		9

CARTON 5/7 (LOUVERS)

Reference	Parts	Quantity
GO		9

CARTON 6/7 (LOUVERS)

Reference	Parts	Quantity
GO		9

CARTON 7/7 (LOUVERS)

Reference	Parts	Quantity
GO		10

ASSEMBLY GUIDELINES

Step 1: Frame & Motor

Step 2: Assembling louvers

Step 3: Install louvers & Connection

Step 1: Frame & Motor

Notes:



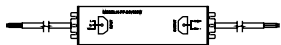

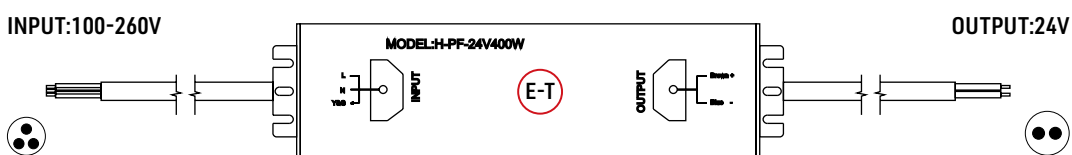
1. Please put the transformer into the side beam where is close to the motor.
2. Put the input wire of the transformer through the post, then pull the line from the notch at the base of post, to connect the power.
3. Please connect wiring in accordance with the diagram below.

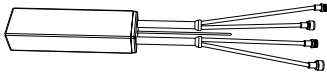
E-T	 <p>Transformer</p>	1
-----	--	---

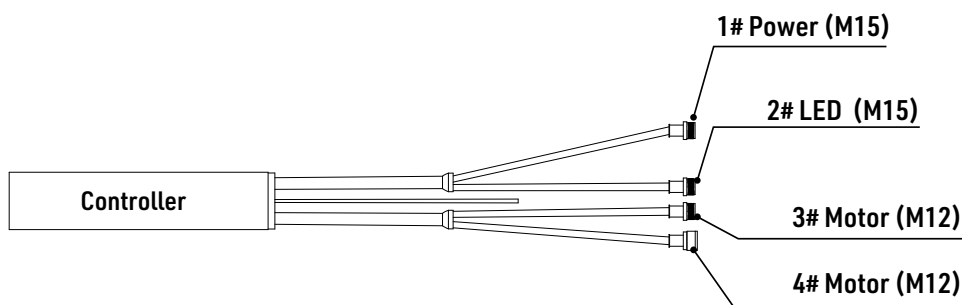

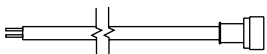
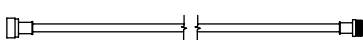
E-C	 <p>Controller</p>	1
-----	---	---



E-P		1
E-P1		1
E-W2	 	1
E-W3	 	1

Step 1: Frame & Motor

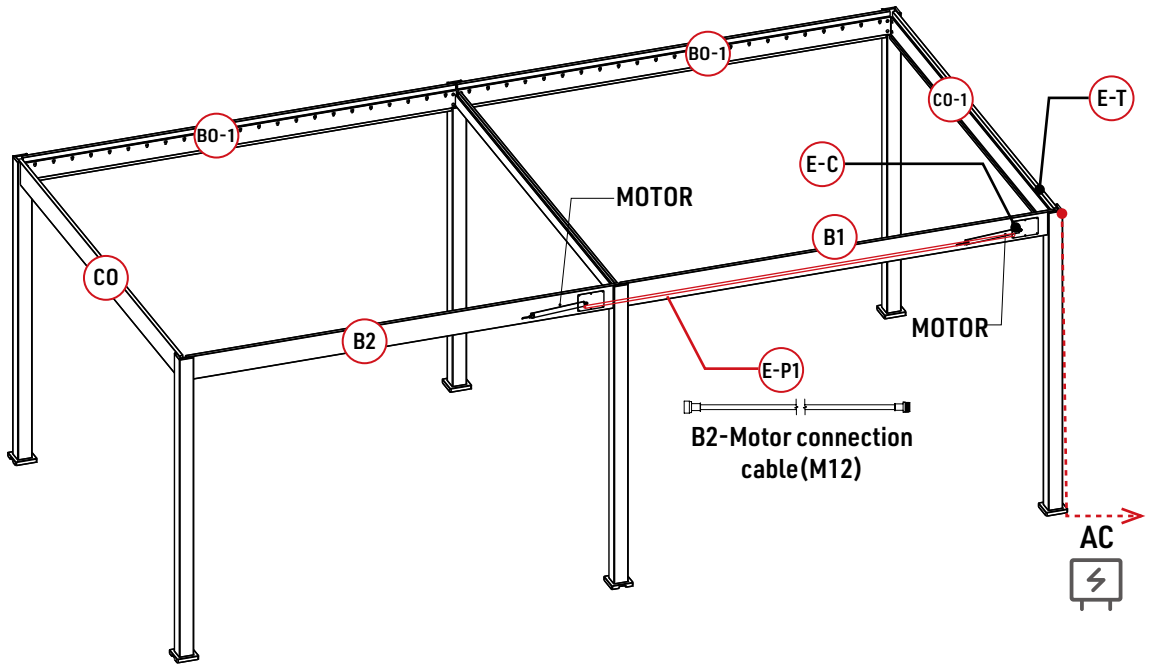



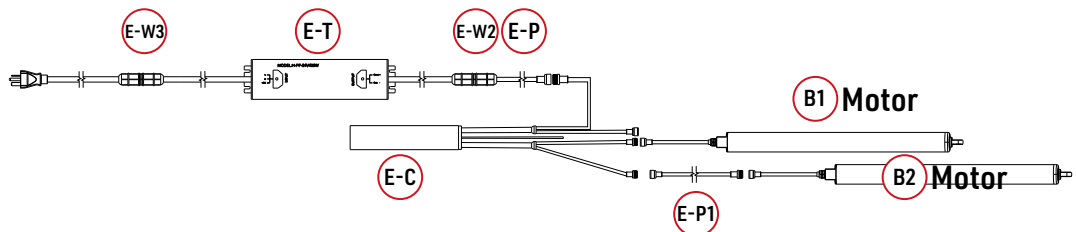





Wiring Diagram



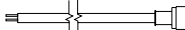

Step 1: Frame & Motor

1-1

Parts

A0		4		
A0-1		2		
E-P		1		
IO		6	X0-1  6x35  4mm	24
JO		6		
E-T		1		

Tools

Z0-1		4mm	1
Z0-2		4mm	1

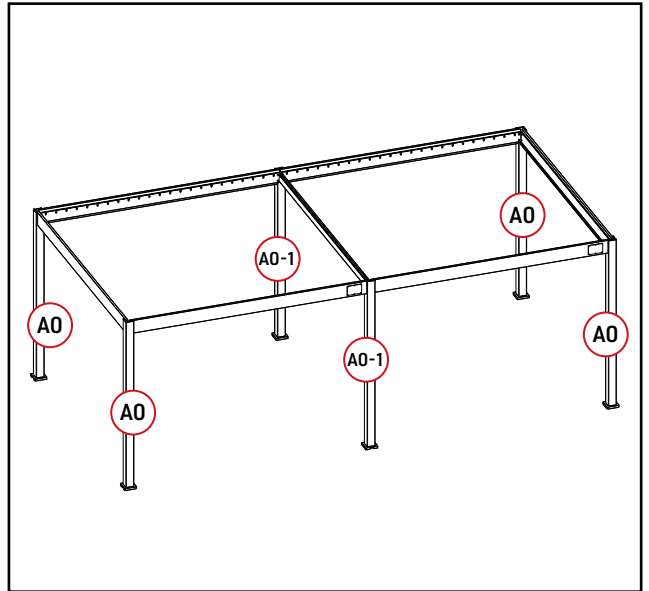

Please connect the output line (E-T) with power cable (E-P) of the transformer by using the waterproof points (E-W2).

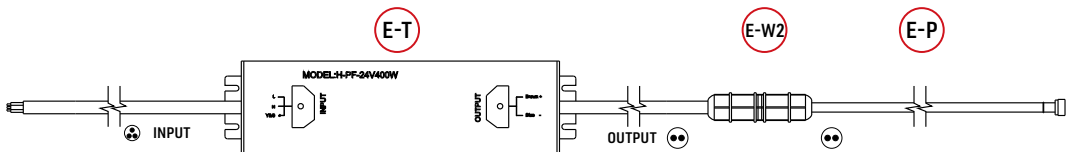

- Please insert the input line of the transformer into the cavity of the post
- Pull the input line from the drainage outlet of the post
- Install the plate and skirt of the post after pulling out the input line

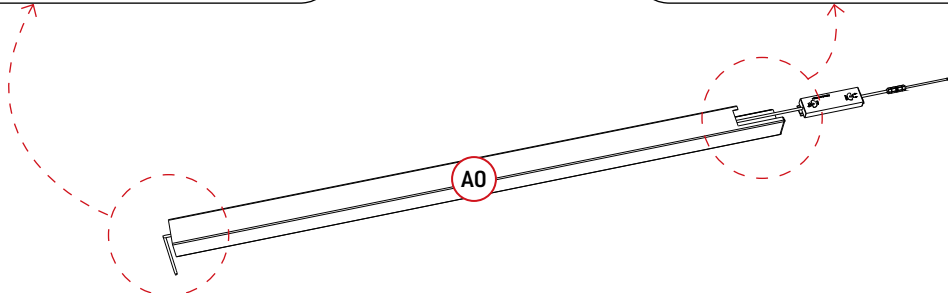
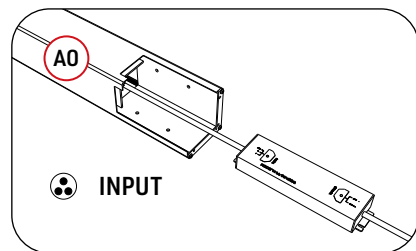
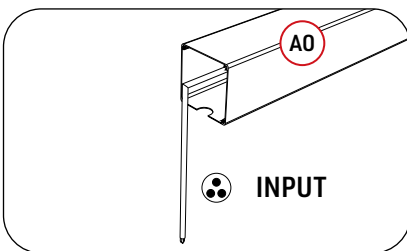

Put the skirt(IO) on the post(A0), please note that notch on the skirt and the drainage outlet of the post should be align as the diagram shows below.

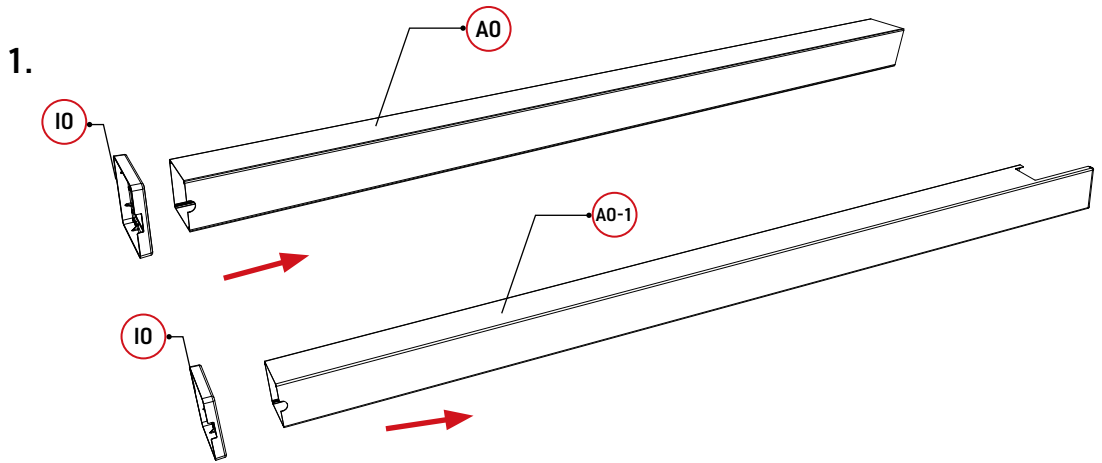

2. Install the plate

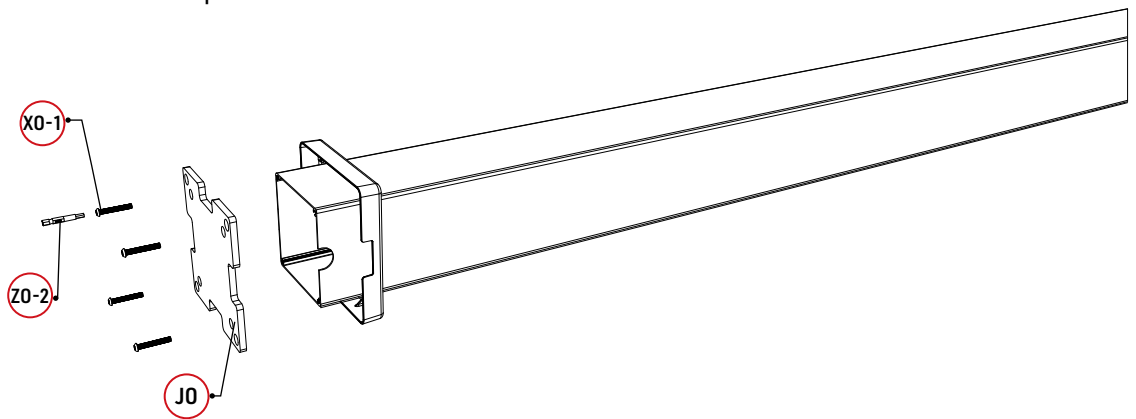

3. Tighten

Using the pistol drill to fix screws on the plate,
please tighten screws with the spanner.

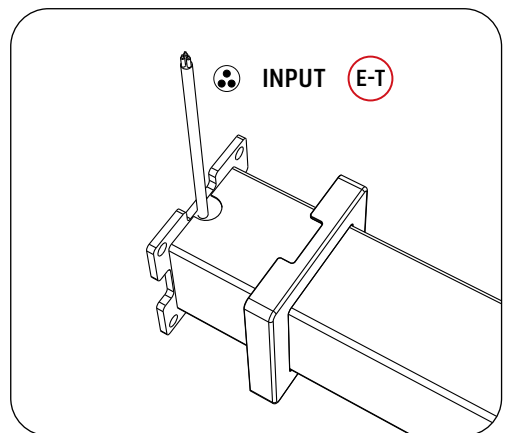
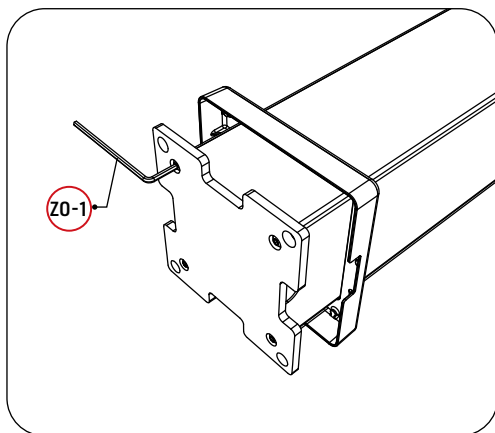



Step 1: Frame & Motor

1-2

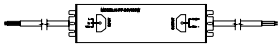

Parts

CO		1
CO-1		1

E-T	 Transformer	1
-----	--	---

Q0	 6mm	8
----	---	---

Tools

Z0-3	 6mm	1
Z0-4	 6mm	1

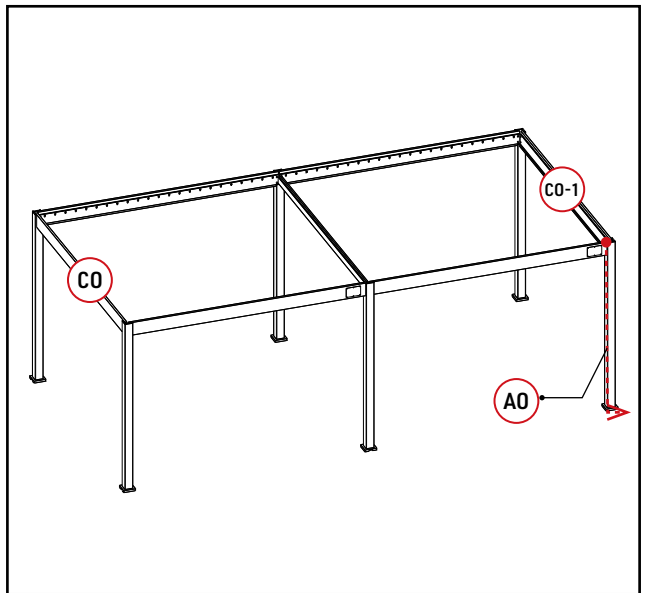

Insert the transformer into the cavity of CO-1, please note to reserve enough length of the power cable(E-P)

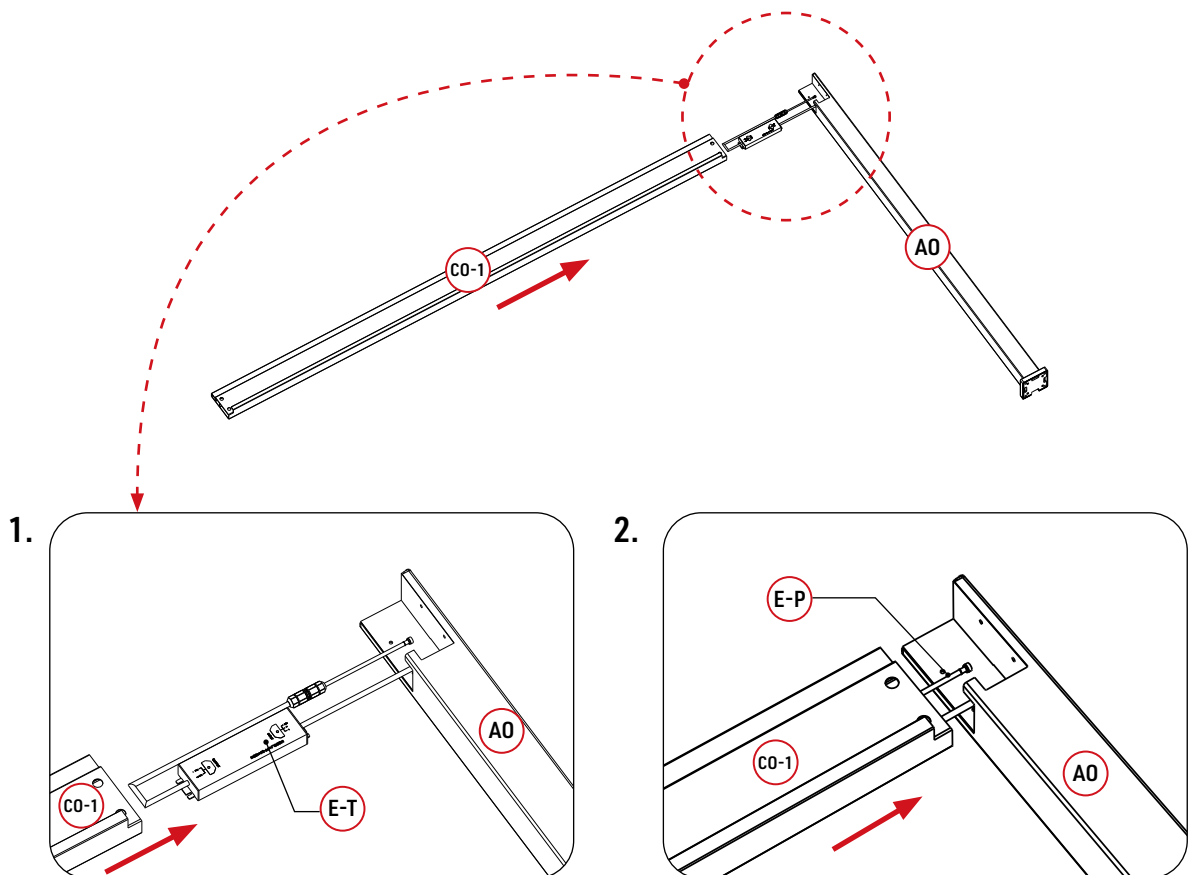

Connect the beam(CO-1) with the post(AO) as the diagram shown below.
Please remember to keep the power cable(E-P) outside of beam

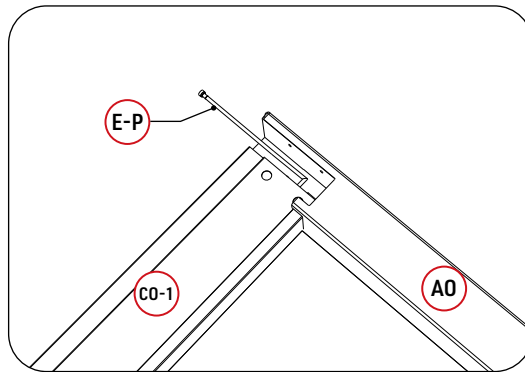

Using the pistol drill to fix screws on the post, then tighten screws with the spanner.

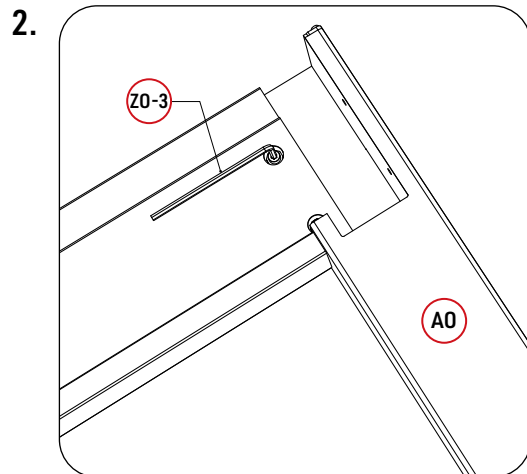
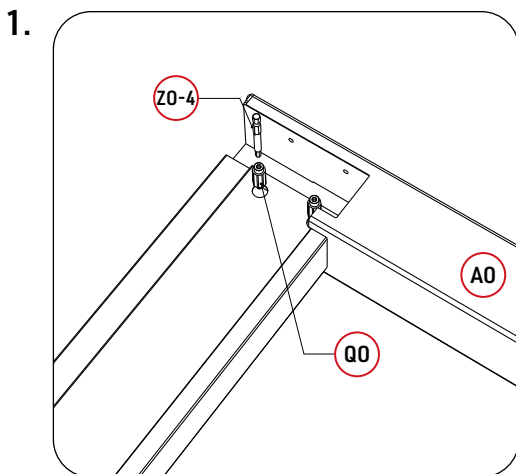
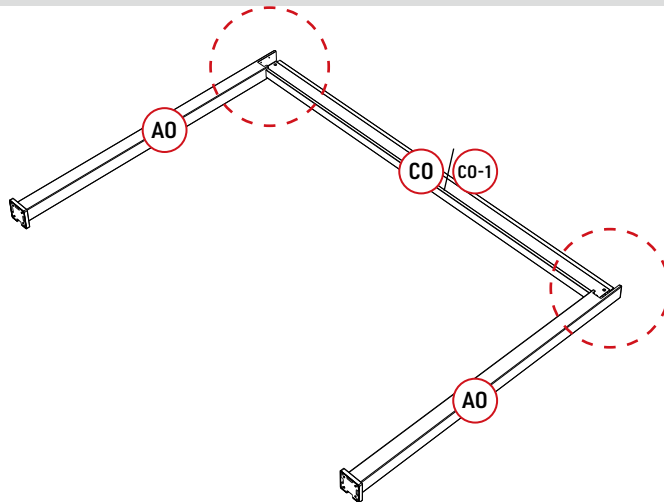

Step 1: Frame & Motor



1-3

Parts

B1		1
B0-1		1

Q0		8
----	---	---

Tools

Z0-3		1
Z0-4		1

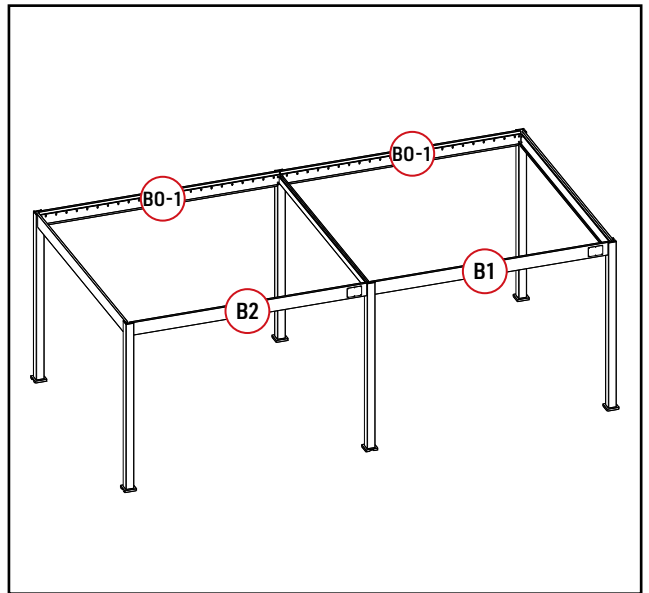

Take down the cover from the beam with the motor, then pull out the cable of the motor, and connect it to the controller

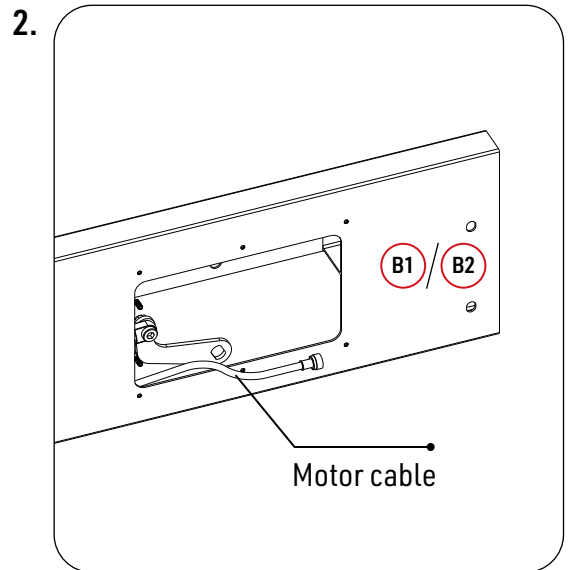
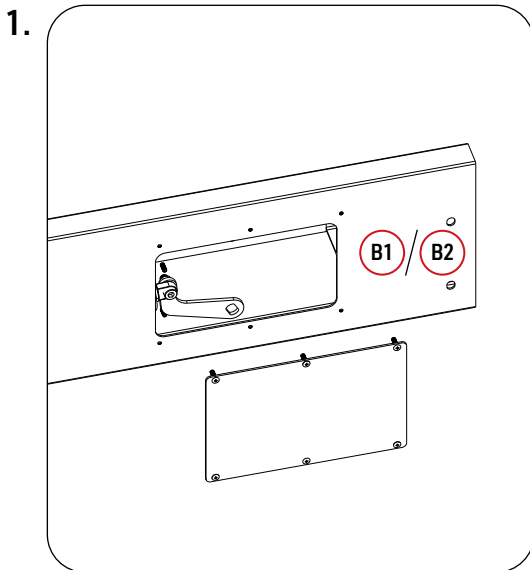
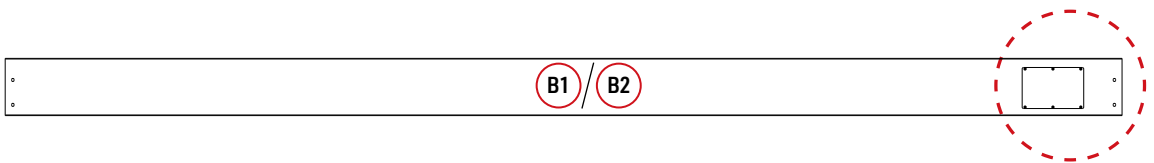

Connect beams to posts

1.

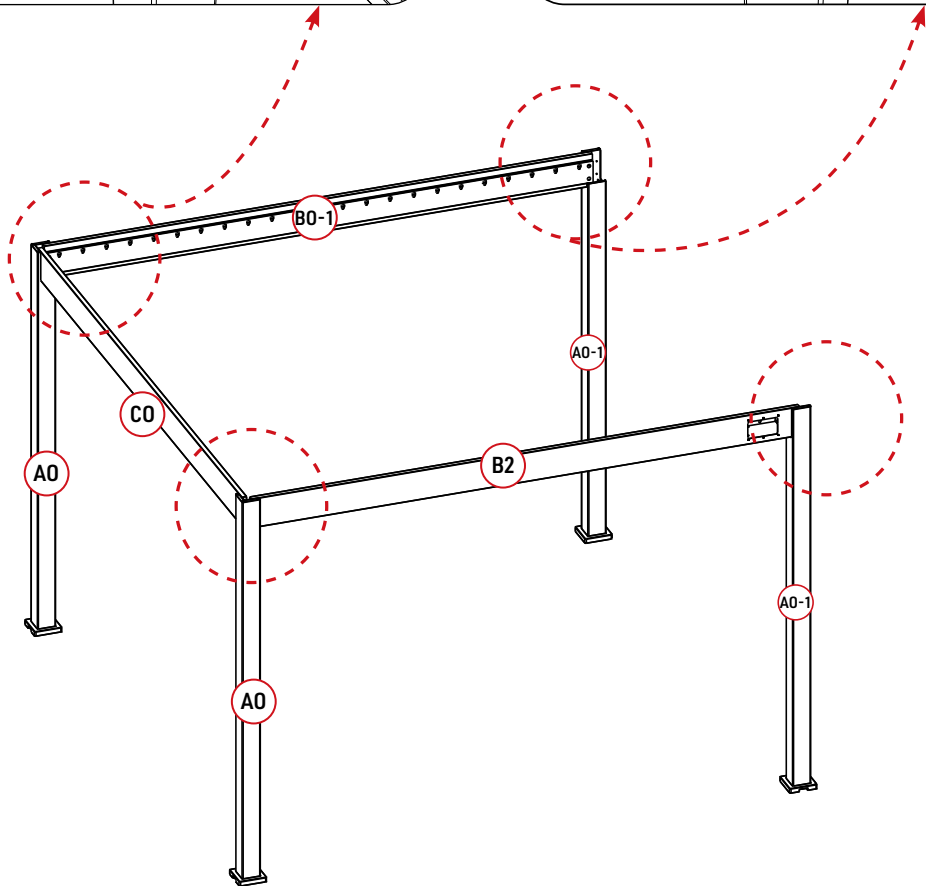
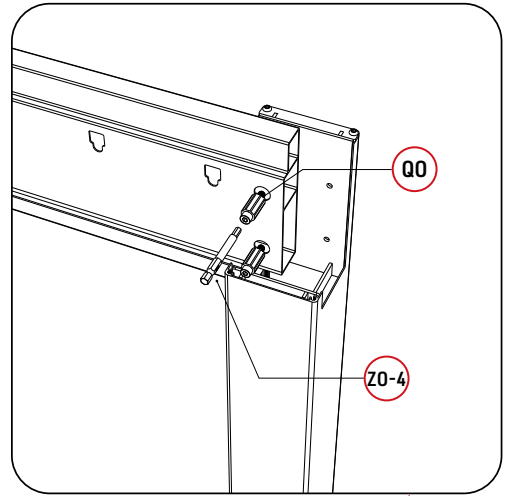
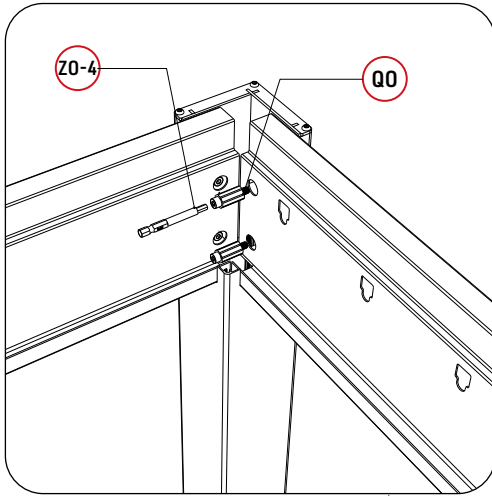

Step 1: Frame & Motor

1-3

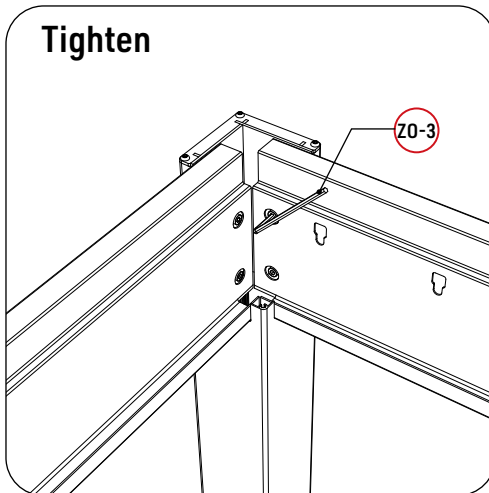
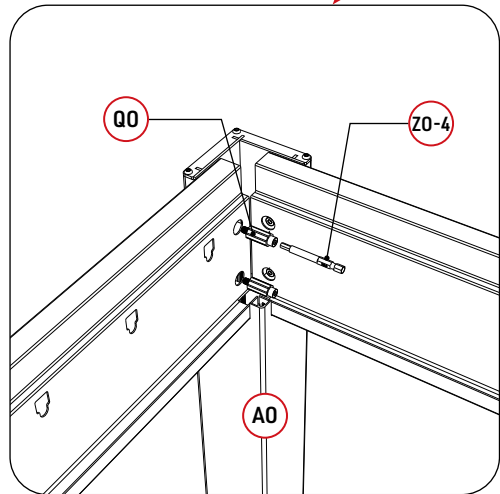
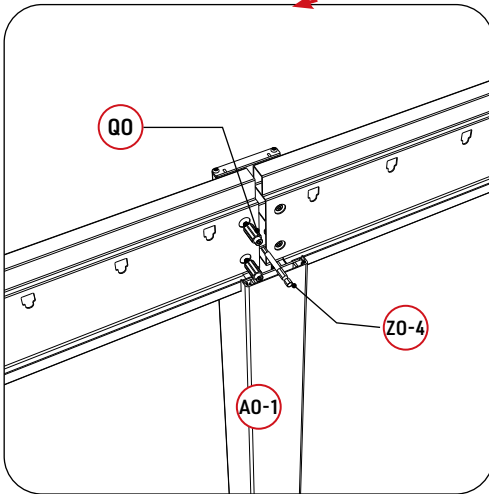
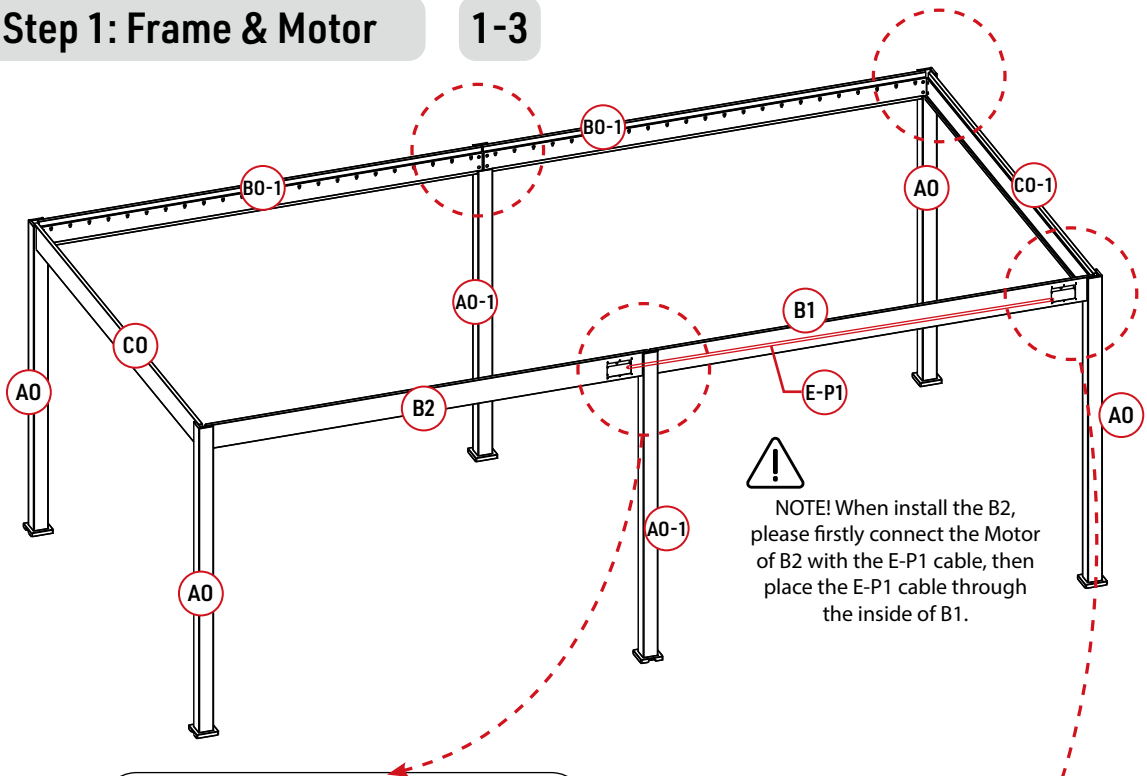





Using the pistol drill to fix screws on the plate, please tighten screws with the spanner.



Step 1: Frame & Motor

1-4

Parts

EO		1
EO-1		2
WO-1		6
XO-3		4

Tools

ZO-1		1
ZO-2		1
ZO-7		1

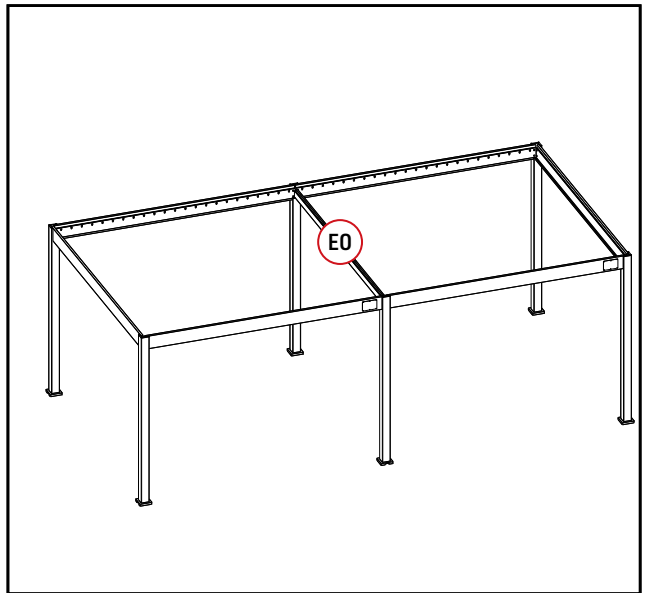

Connect beams to columns

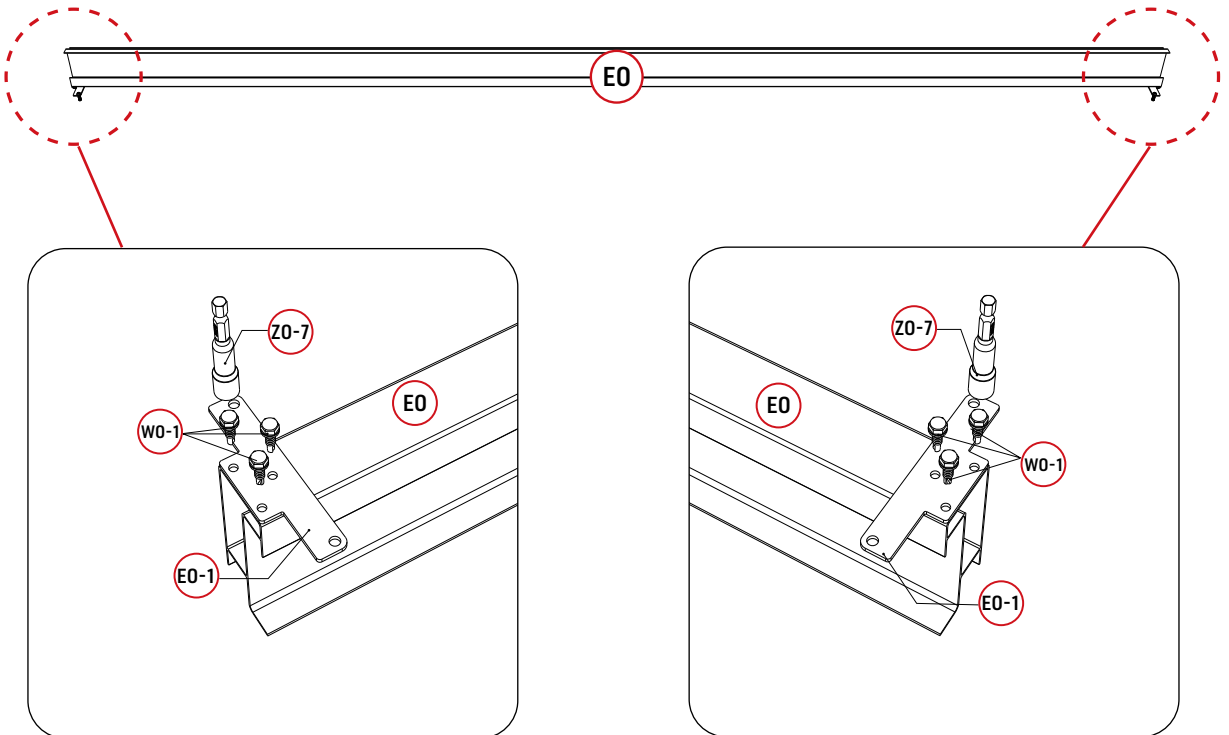

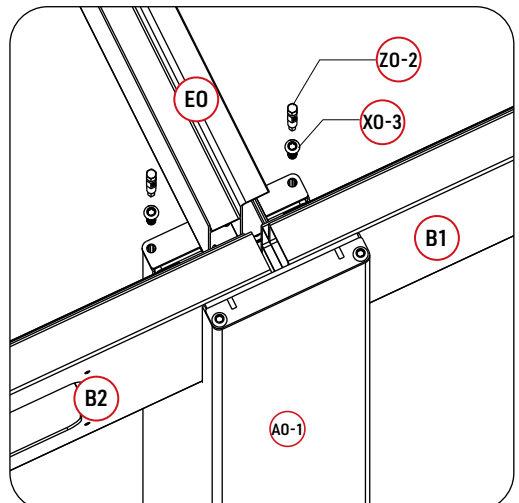
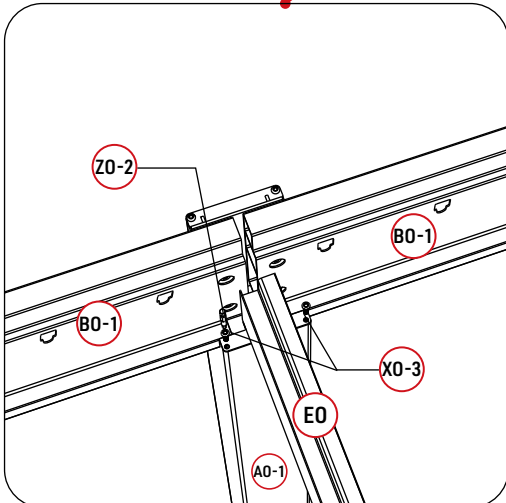
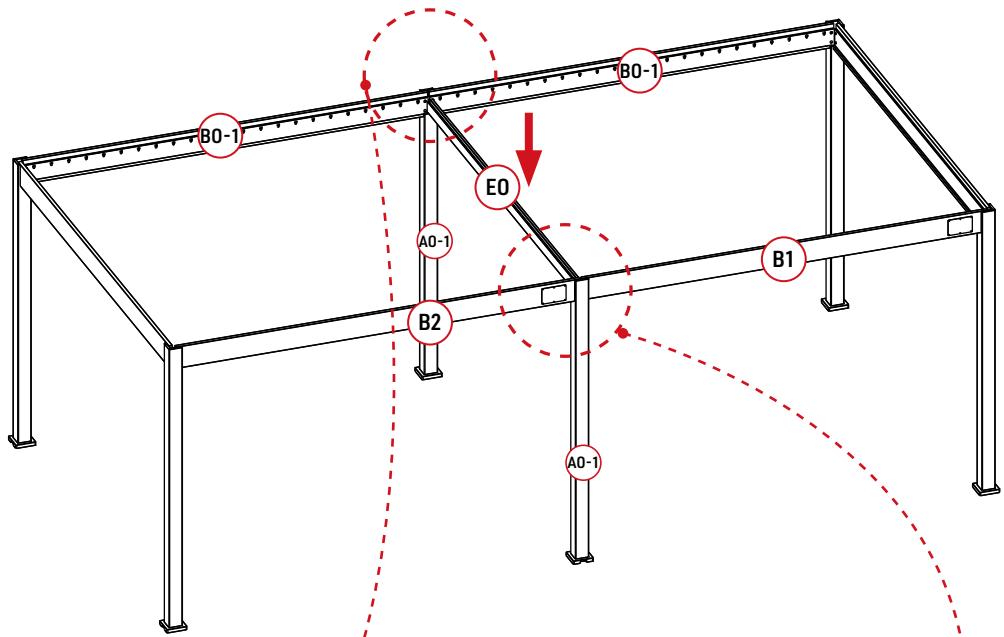



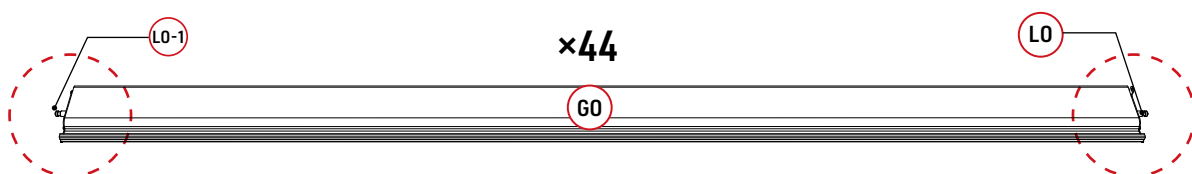
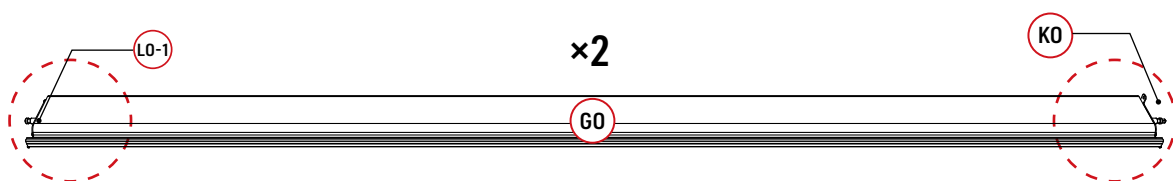
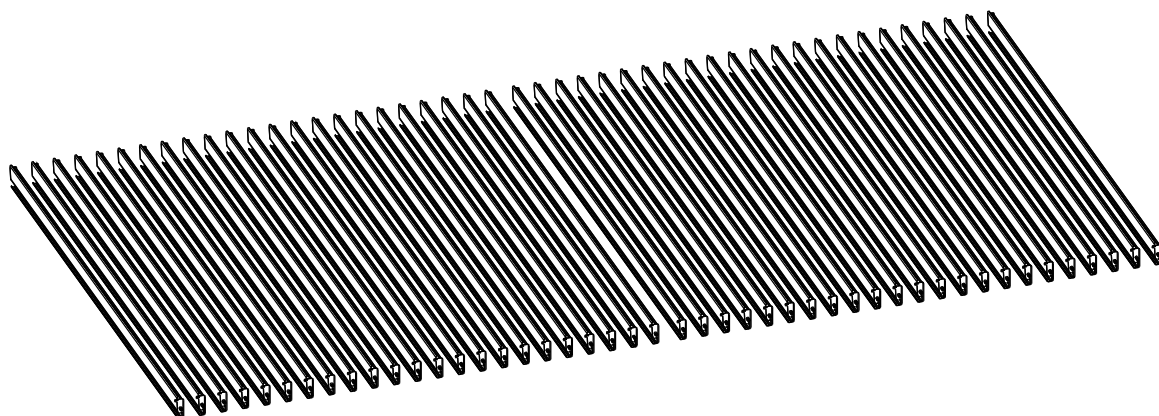

Step 2 : Assembling louvers





Step 2 : Assembling louvers 2-1

Parts

LO		44	MO-1		90	VO		90
LO-1		46	XO		90			
MO		90	UO		90			

Tools

ZO-3		1
ZO-4		1

Note: To avoid any broken of the plastic parts(MO), when use the pistol drill, please reduce the twisting force of it .

It should be noted that part MO should not be tightened too much, especially when using a cordless screwdriver.

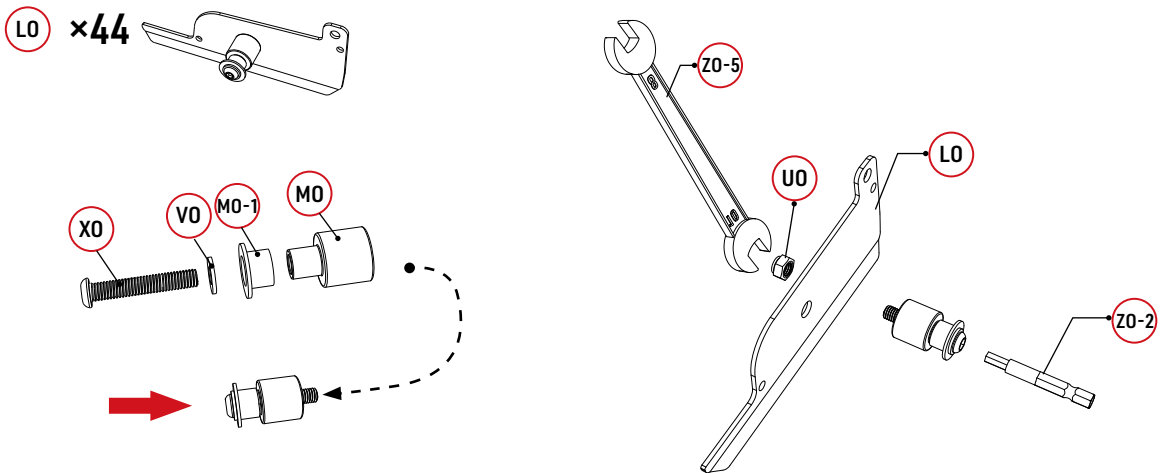



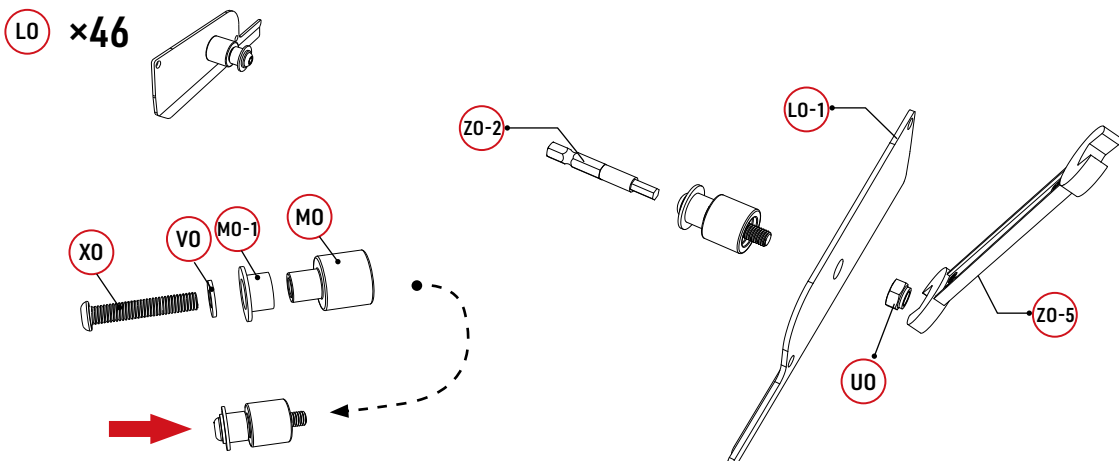



Louver sealing plate





Step 2 : Assembling louvers 2-2

Parts

GO		46
KO		2
LO		44
LO-1		46
WO	 	184

Tools

ZO-1	 4mm	1
ZO-2	 4mm	1
ZO-6	 PH2	1

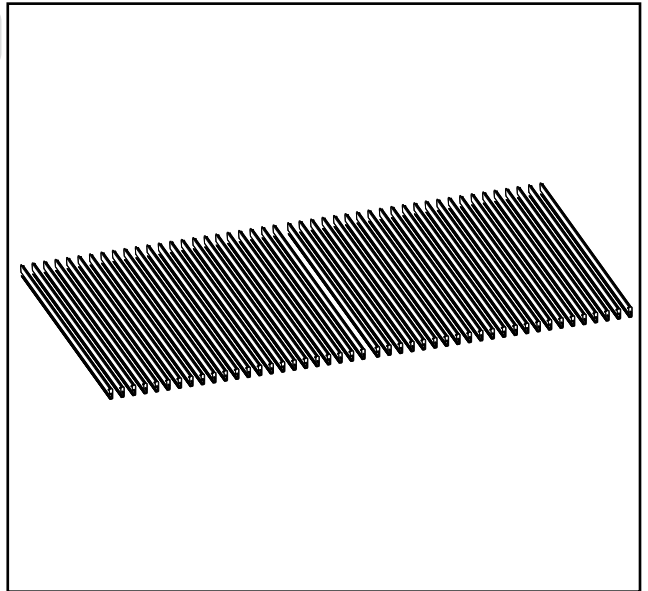

Connect end caps with the first louvers (KO)

Completion Diagram

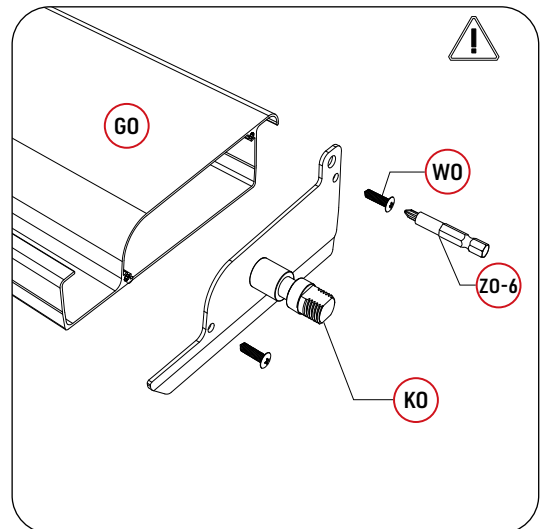
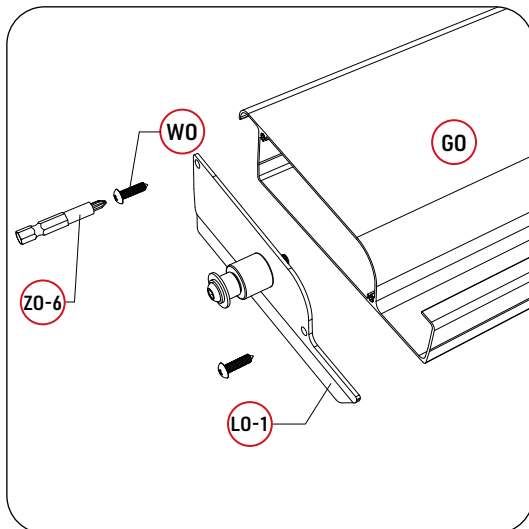
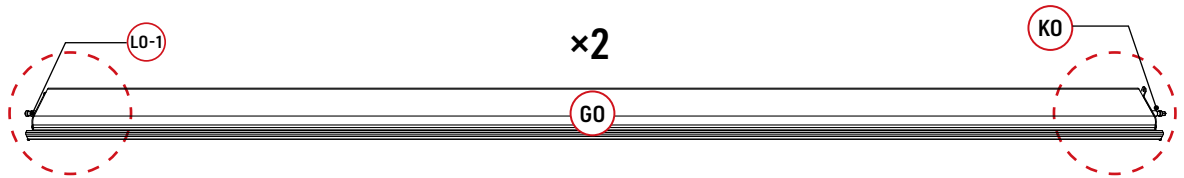

Connect end caps with the rest louvers (LO)

Completion Diagram

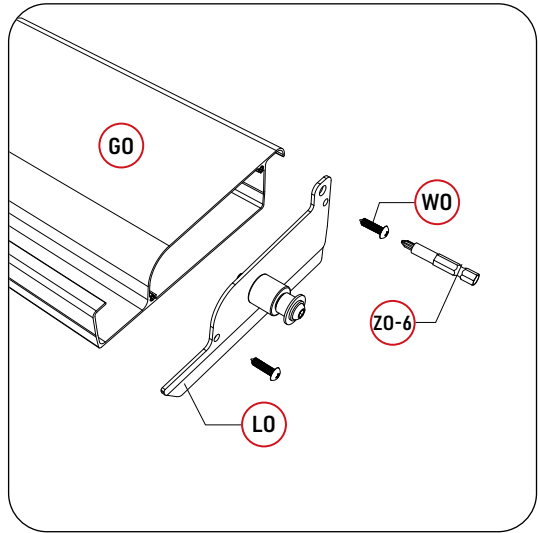
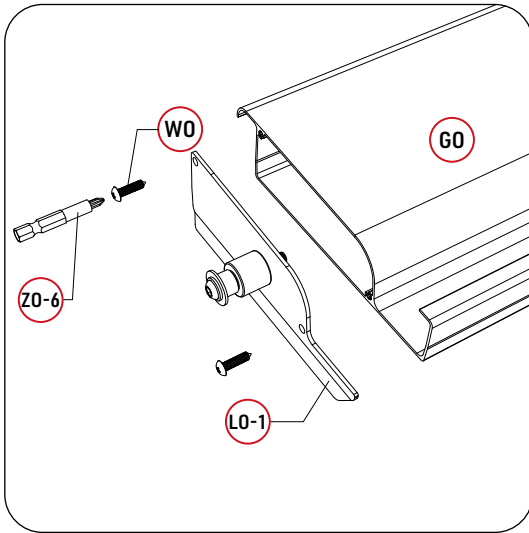
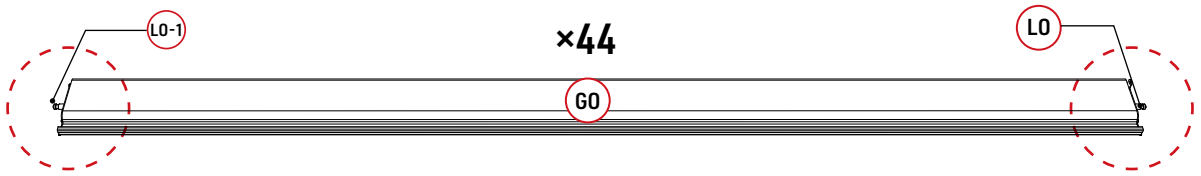

Step 3: Install louvers & Connection

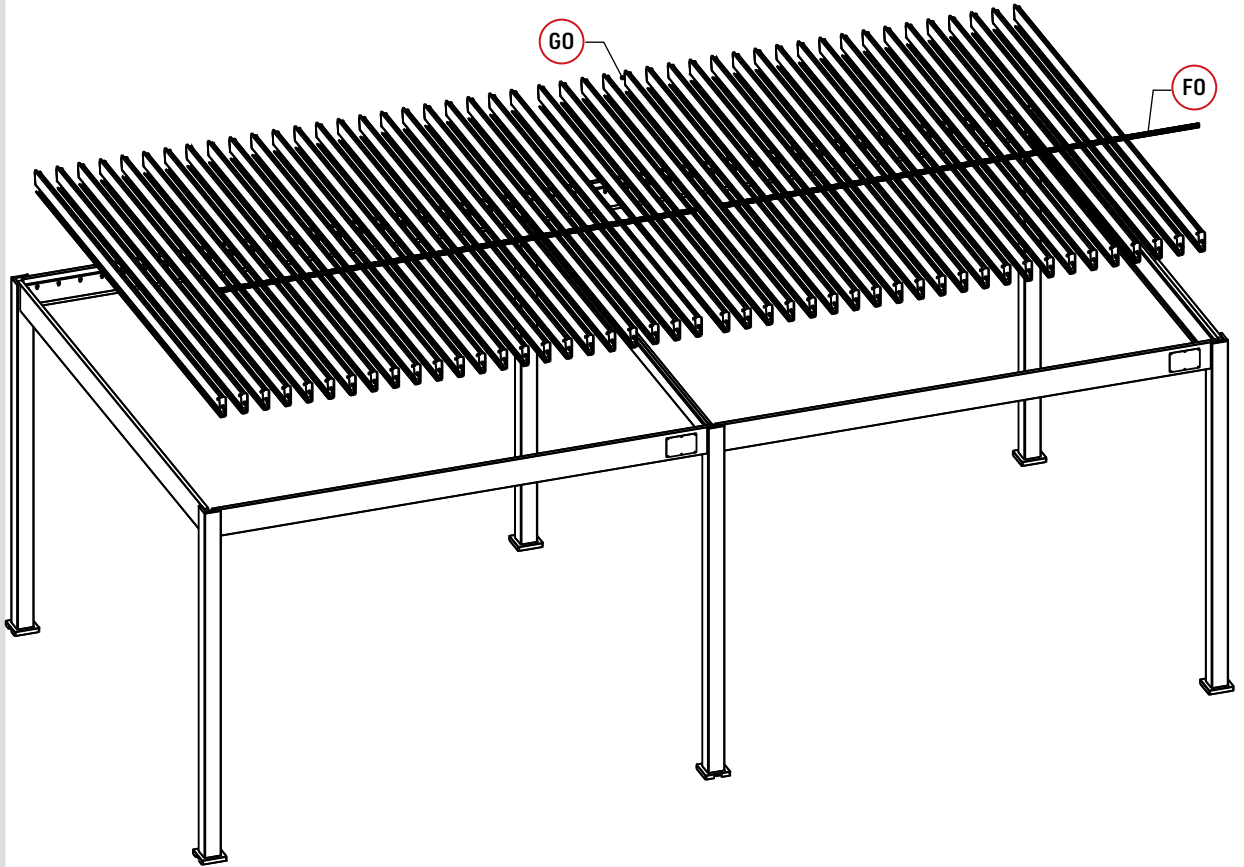

Fasten rubber plugs on both ends of the louvers

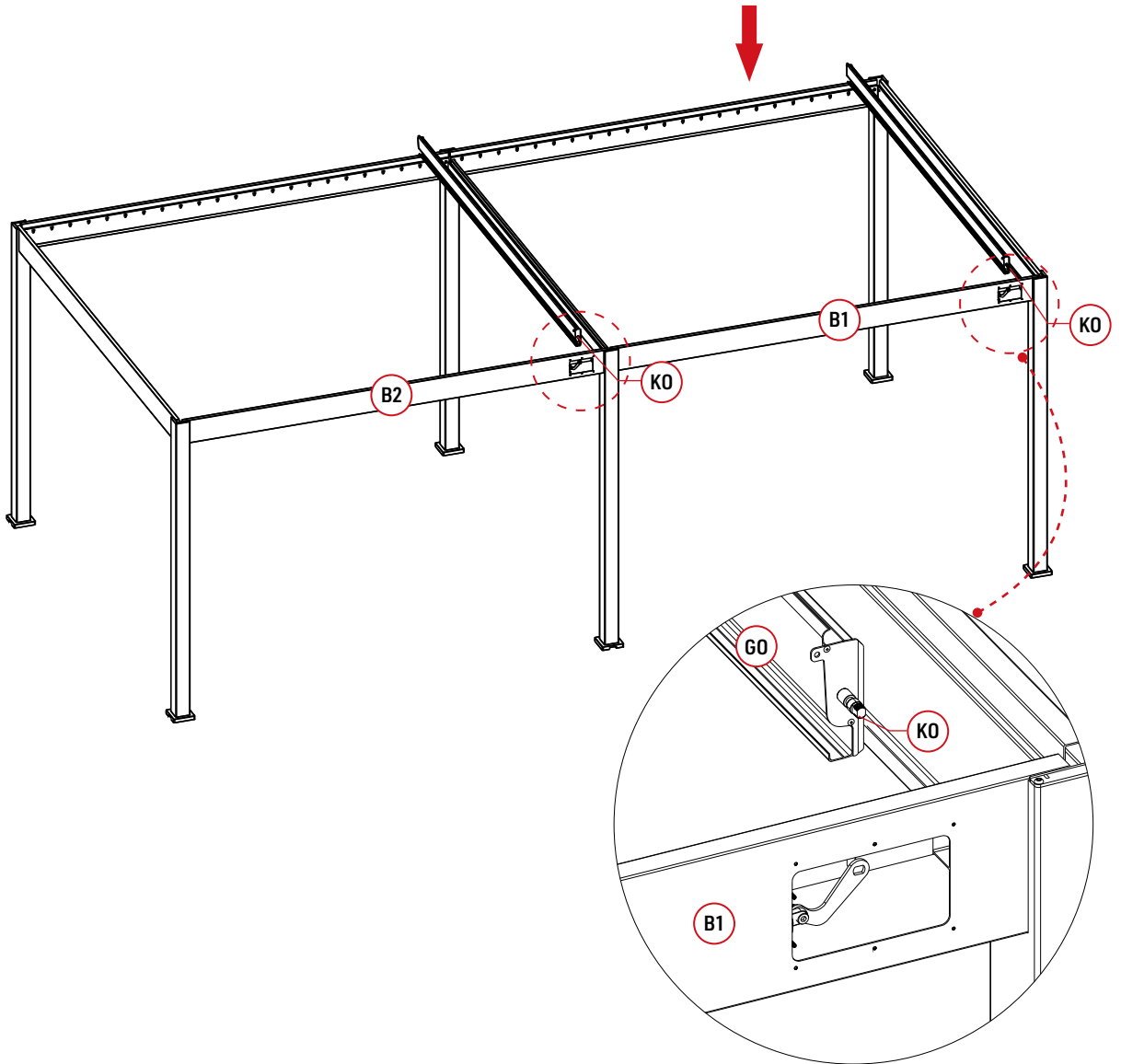

1

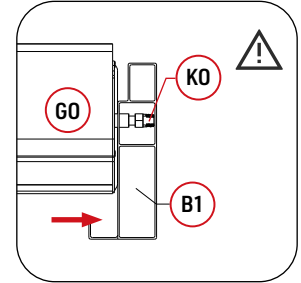
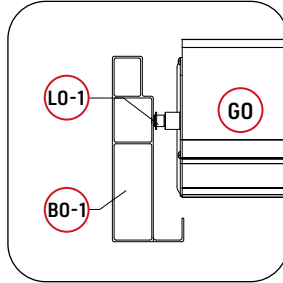
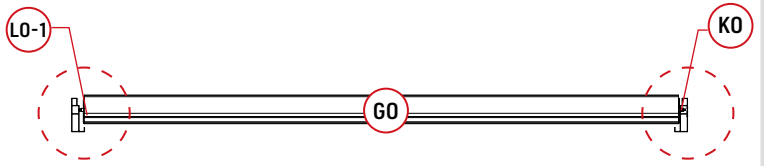
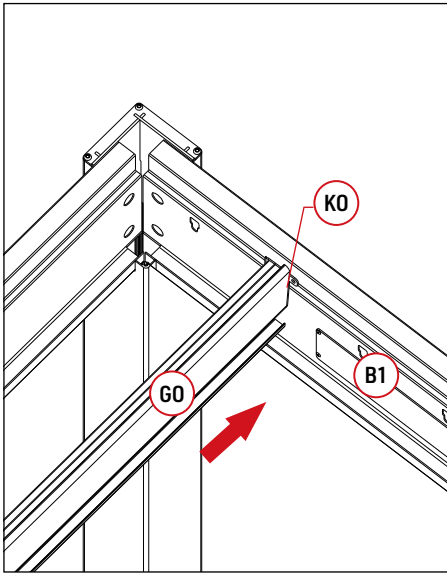

2

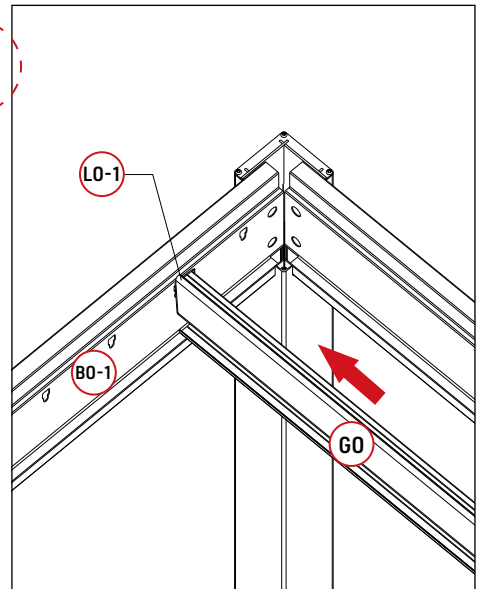
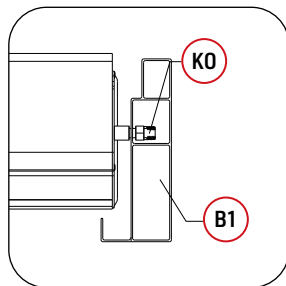
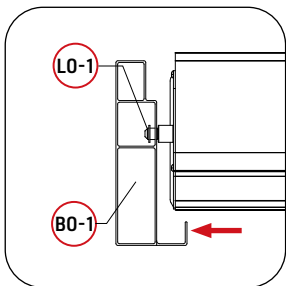
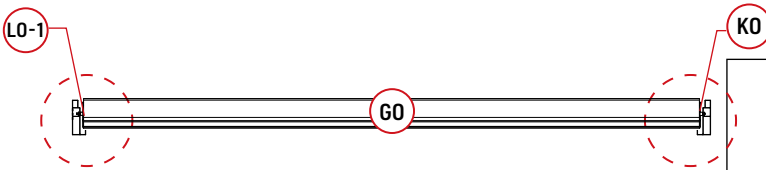

Step 3: Install louvers & Connection

3-2

Parts

U0-3	 M14	2
------	---	---

Make the louver flat, then connect the motor rocker arm to the spindle

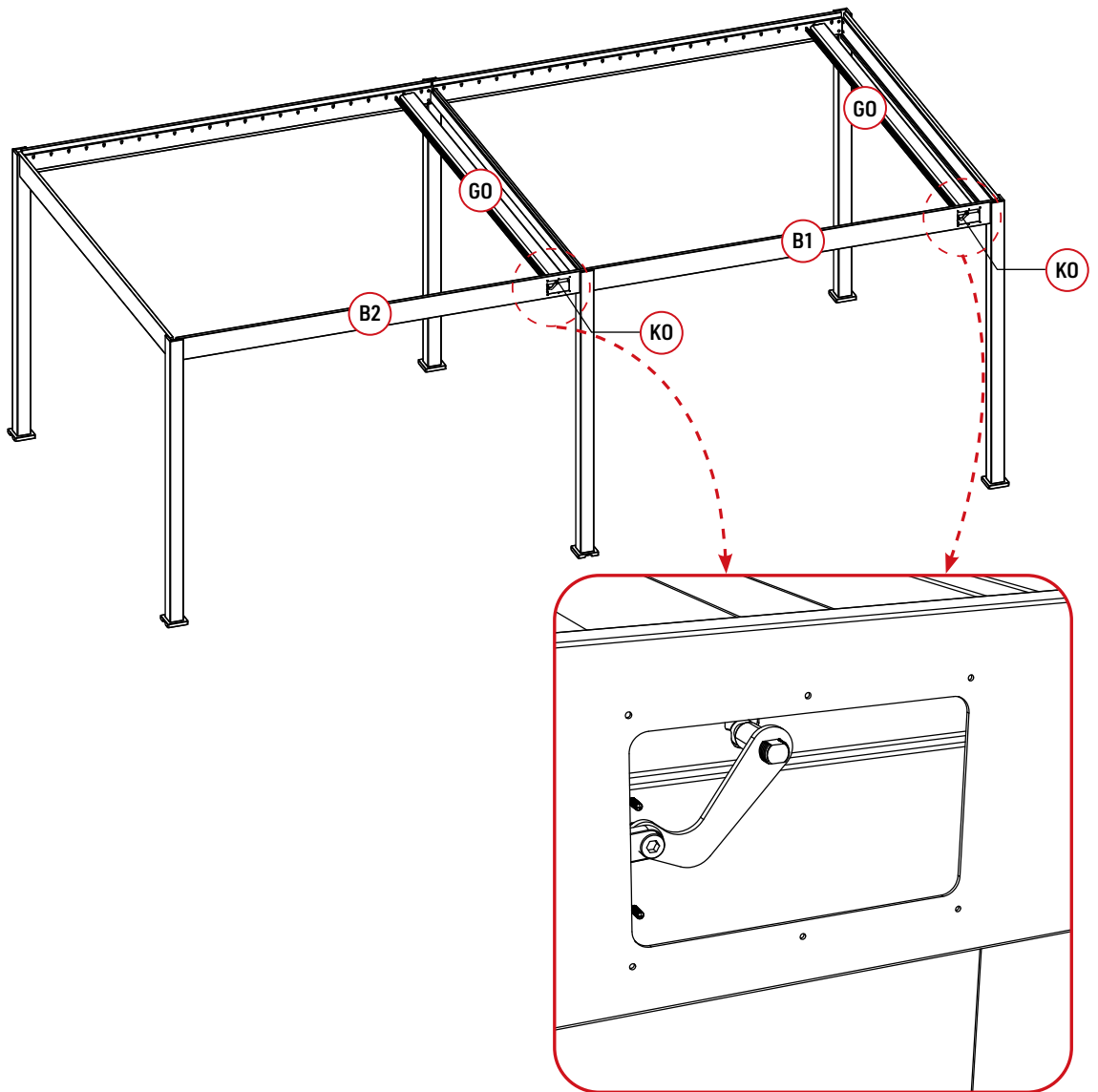

1.

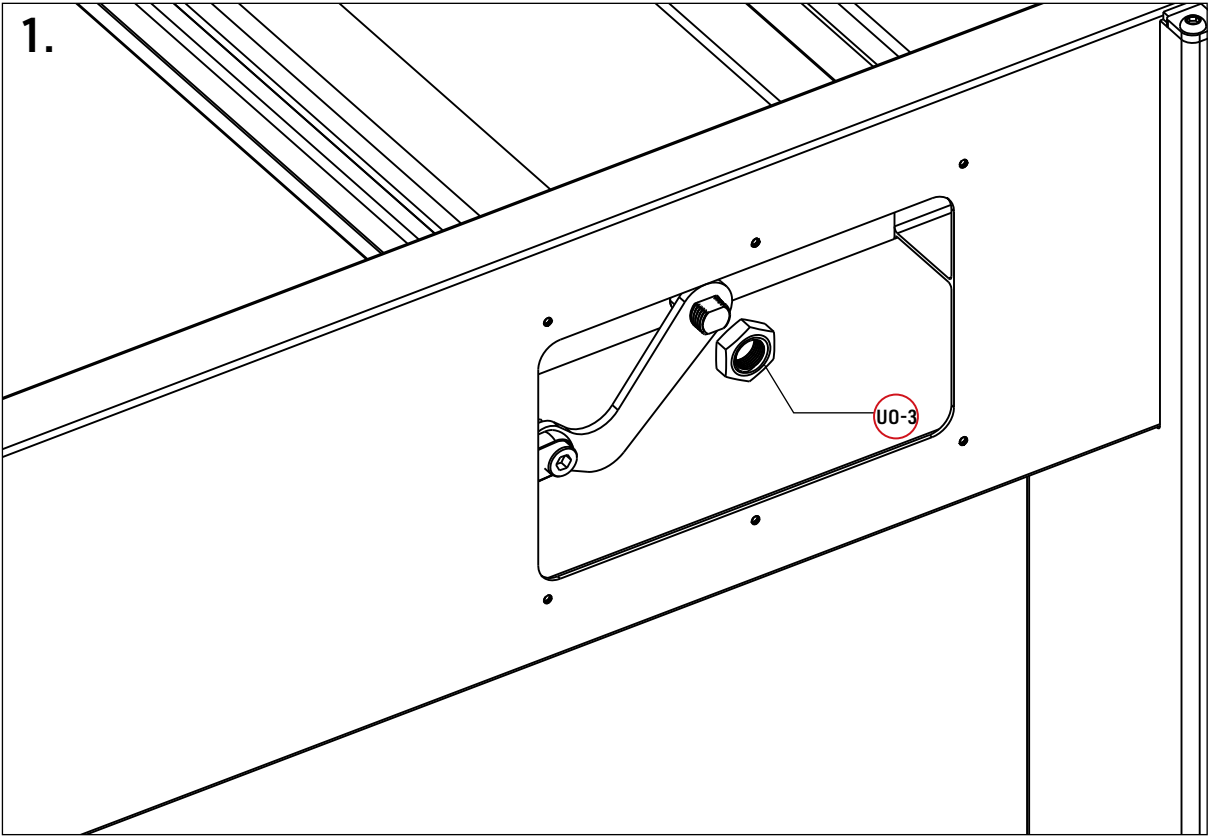

2.

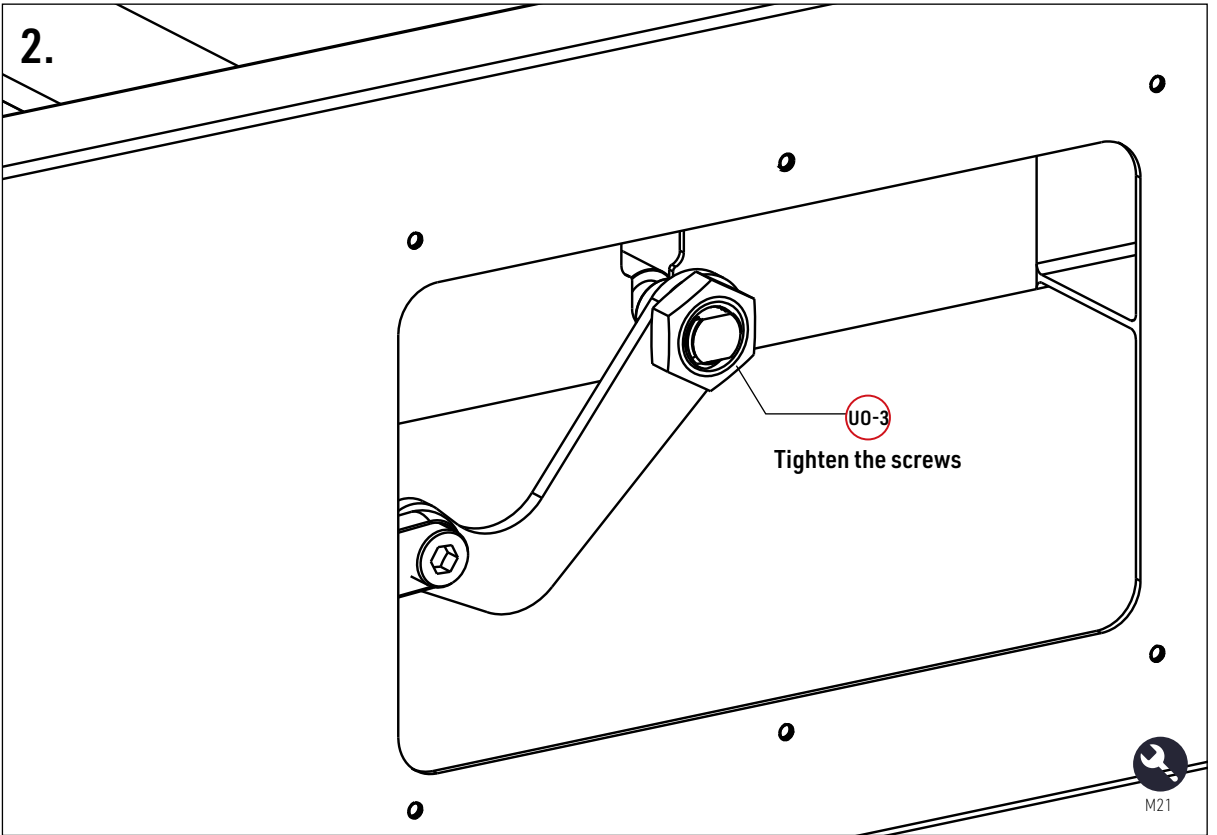

Step 3: Install louvers & Connection

3-3

Pull the E-P extension line as the diagram shows below, then connect the extension line with the 1# line of the E-C.

Connect the 3# line of the E-C with cable of the motor
Connect the extension line(E-P1) with the 4# line of the E-C

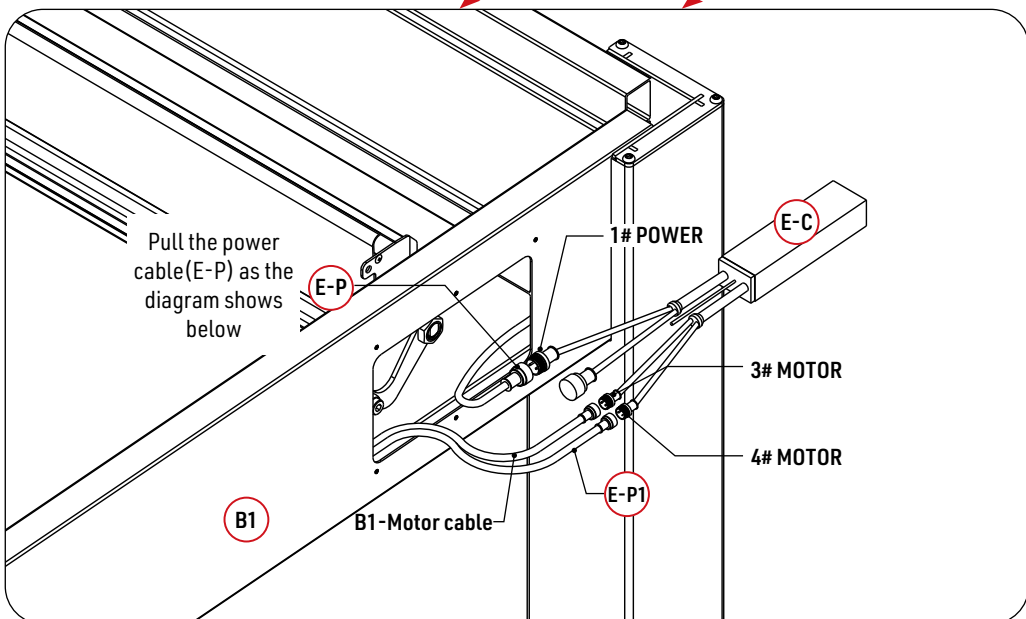
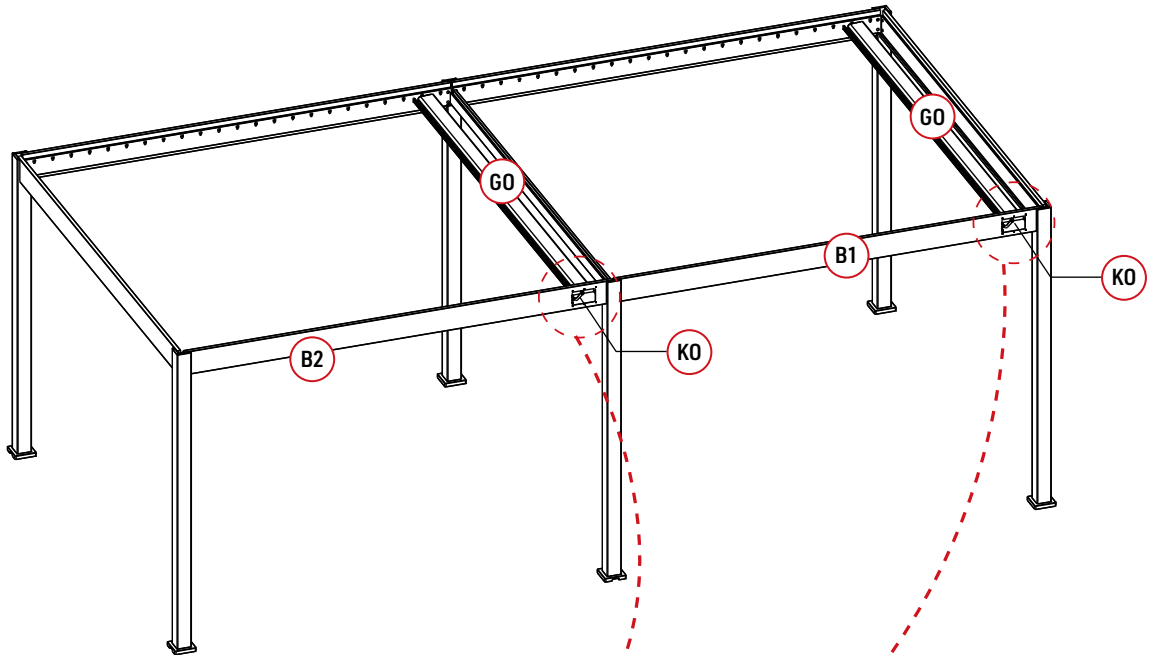

Insert the LED strip into the gutter

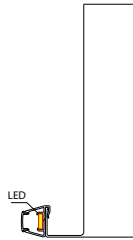

Put the output line of the LED controller(L-C1) into the cavity of the post.

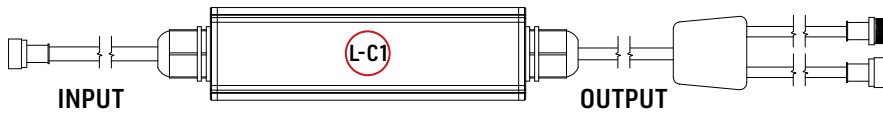

1.

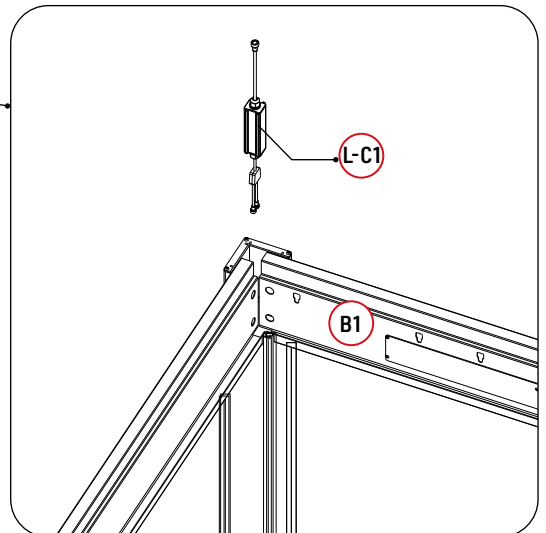
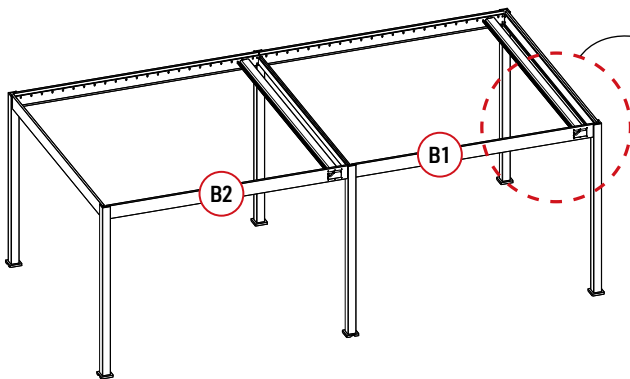

Please note that the Input End of the LED controller should be in the upward direction while the Output End should be in the downward direction.
For the two cable of the Output End, please pull them from the drainage notch by using the supplied brush.

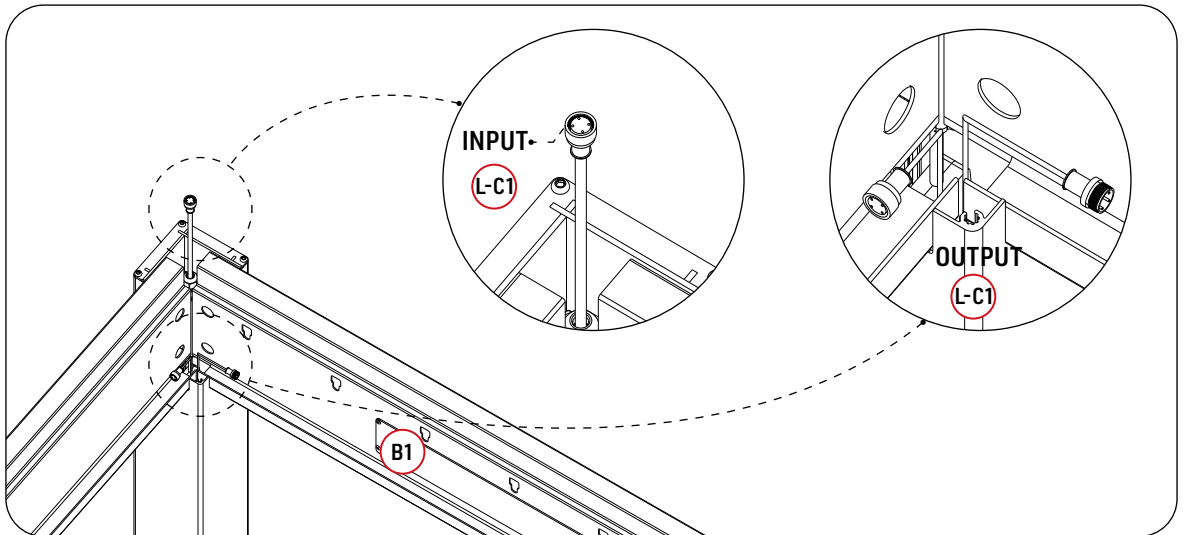

Connect the Input line of the LED controller(L-C1) with the 2# LED of the Controller(E-C).

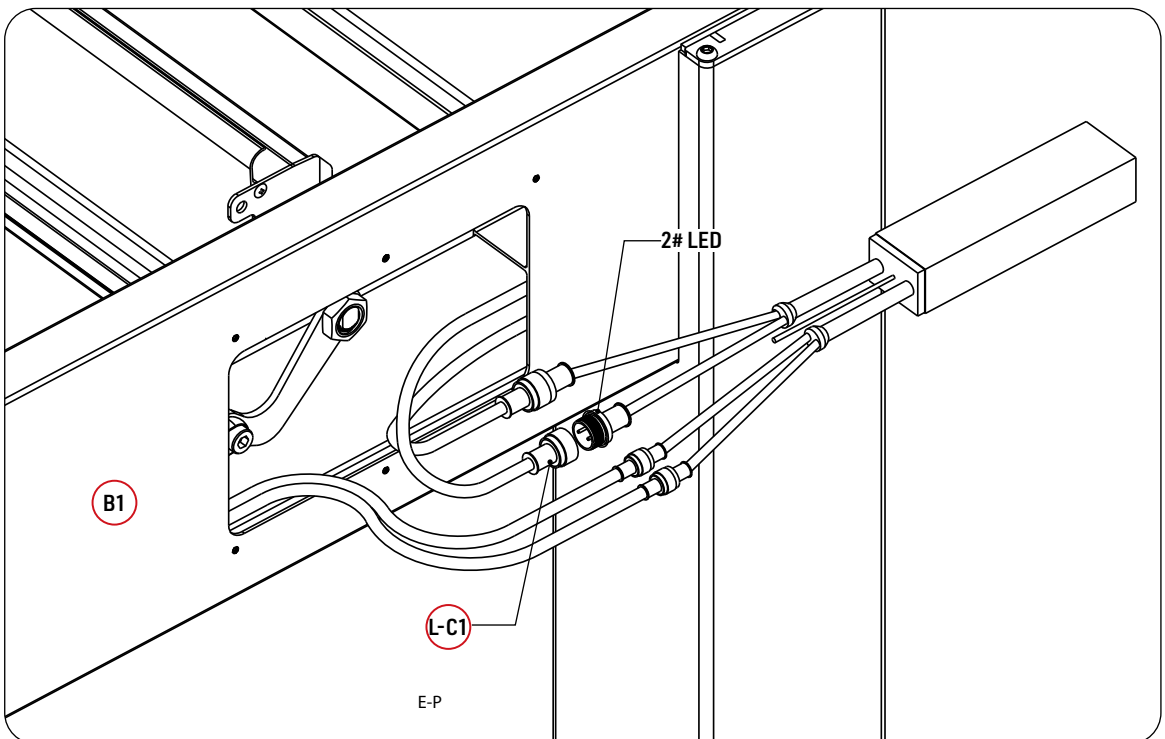

Step 3: Install louvers & Connection

LED

Install all LED strip in series, then connect the two ends of the LED strip with the two output line of the LED Controller(L-C1)

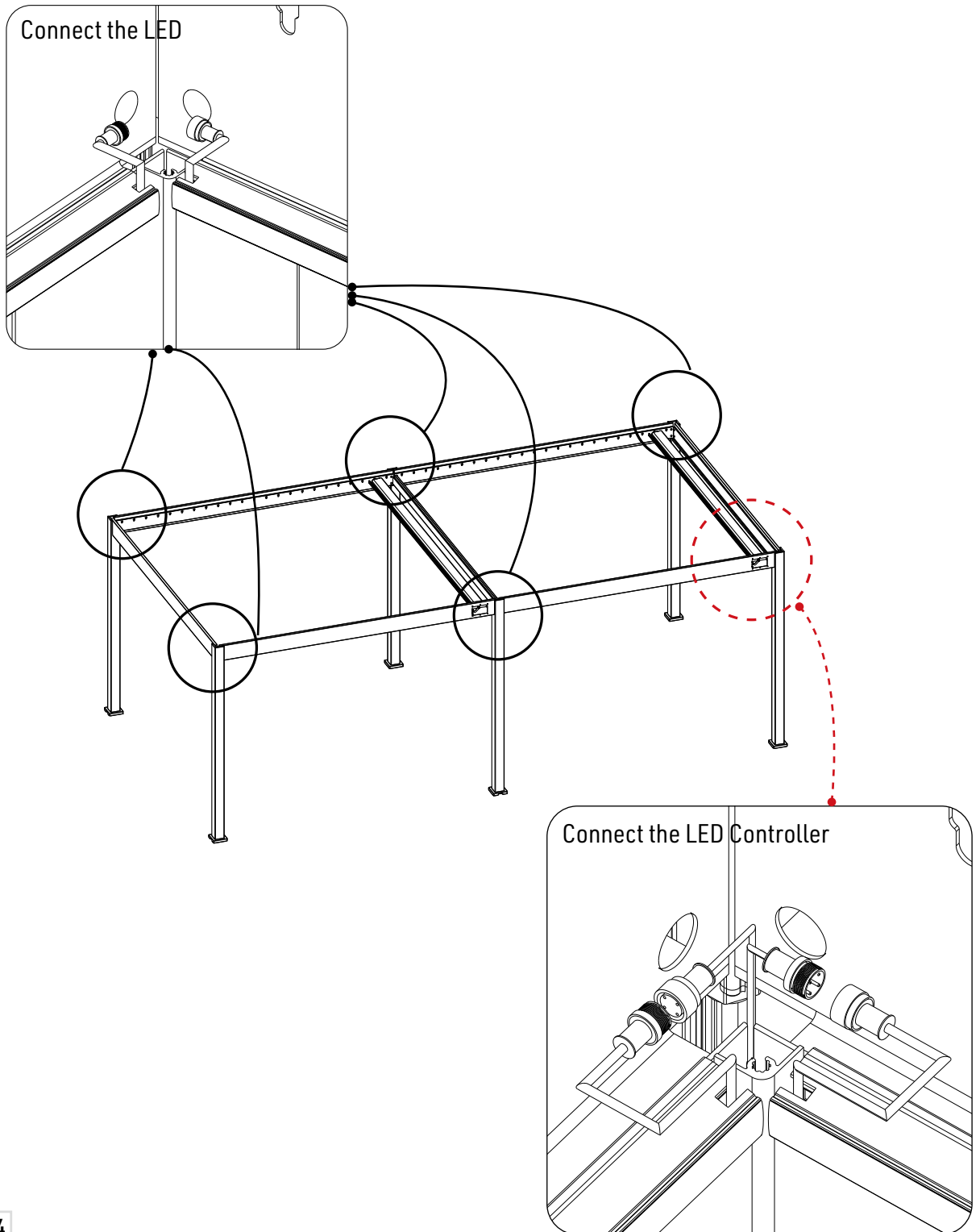

Step 3: Install louvers & Connection

E-R		1
-----	---	---

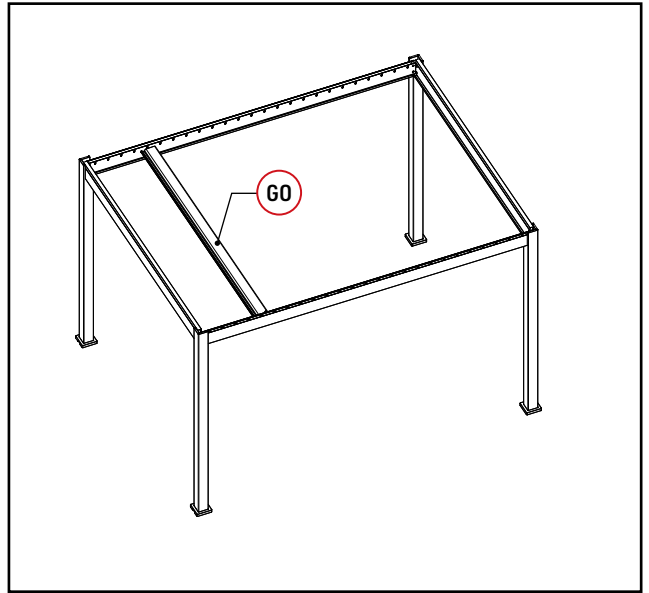

Motor Connection

1. Press the UP button on the remote control and hold it for 3-5 seconds until the indicator light stays on.
2. Continue holding the button (important).
3. Plug in the power cord while still holding the UP button. If you feel a slight vibration in the main louvers, it means that the remote control has been paired with the motor, and you can release the button.

Step1.

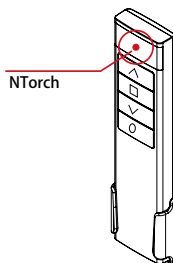
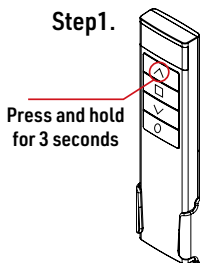

Step2.

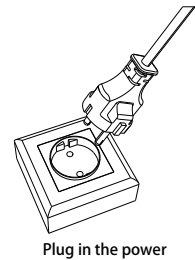

Plug in the power

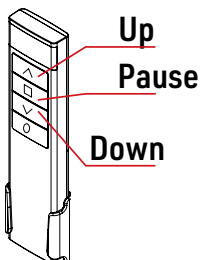

The remote controller has the functions below:

- Control the ON and OFF of the LED
- Control the rotation of the louvre

If you need to control the LED color, please download the APP below.

LED color control can only be available when you have access to WIFI



Tuya Smart

Tuya APP network connection

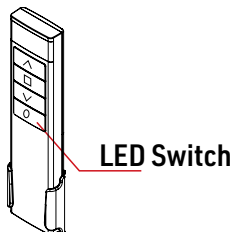

If the LED cannot be connected when powered on, please reset the controller of the LED

Repeat power on and off for 5 consecutive times, also clear previous network connection, enter Smart cong mode, the output LED will ash 10 times.

After connecting all cables and adjusting of LED strip, louver rotation, please put the Controller(E-C) into the cavity of the beam(B1) as the diagram shows below.

To avoid any struck of cables, please note that the Controller(E-C) and all cables should be keep away from the movement range of the Motor's swing arm.

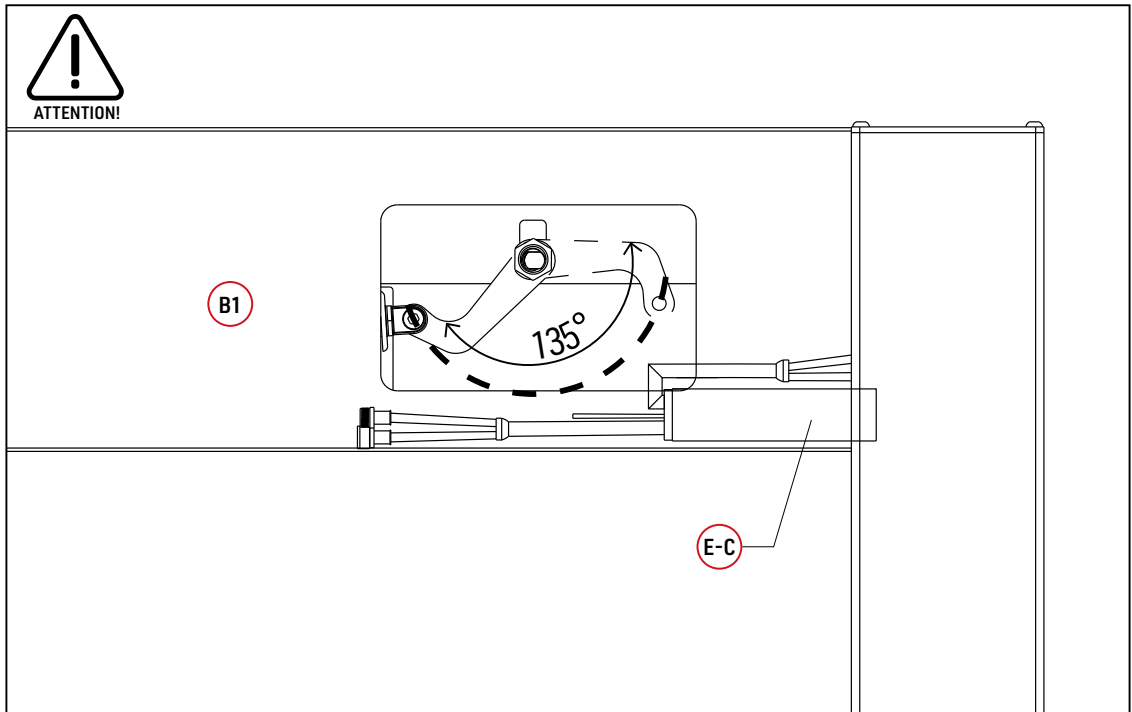

Step 3: Install louvers & Connection

3-6

Parts

S0		92
----	---	----

1. Install other louvers on the beam and make the louver flat
2. Cover the screw head with plastic caps

1

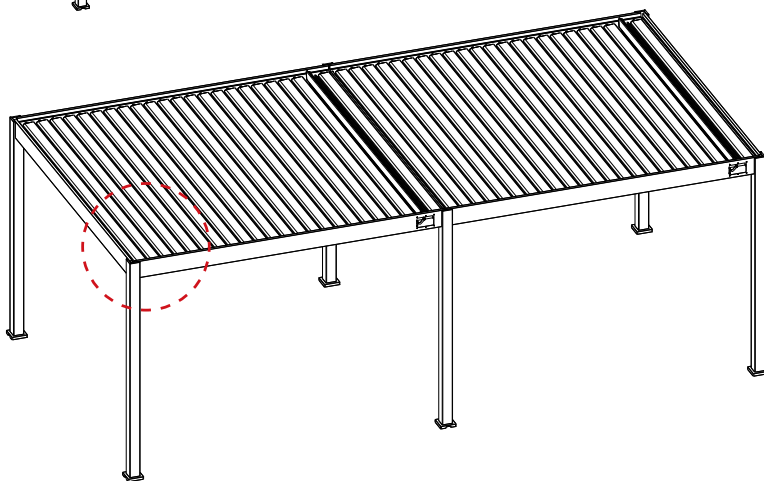
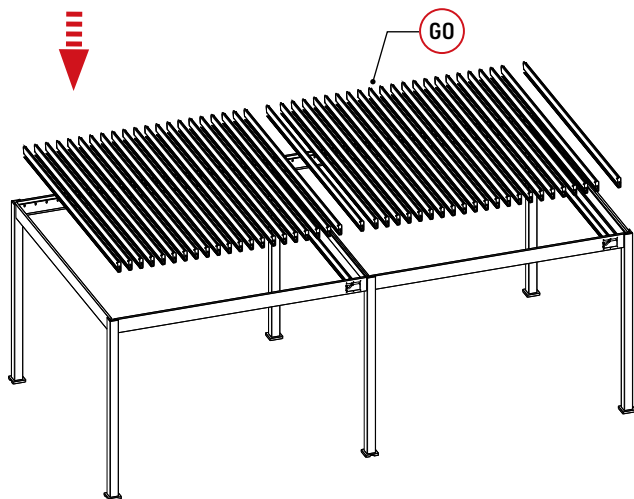



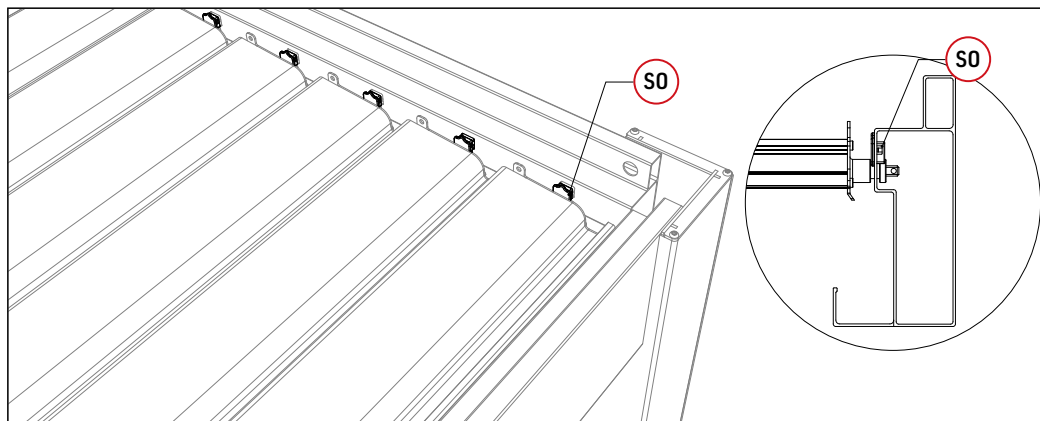

2



Step 3: Install louvers & Connection

3-7

Parts

F0		2
X0-2		46
V0		138
U0		46
U0-1		46

Tools

Z0-1		1
Z0-2		1
Z0-5		1

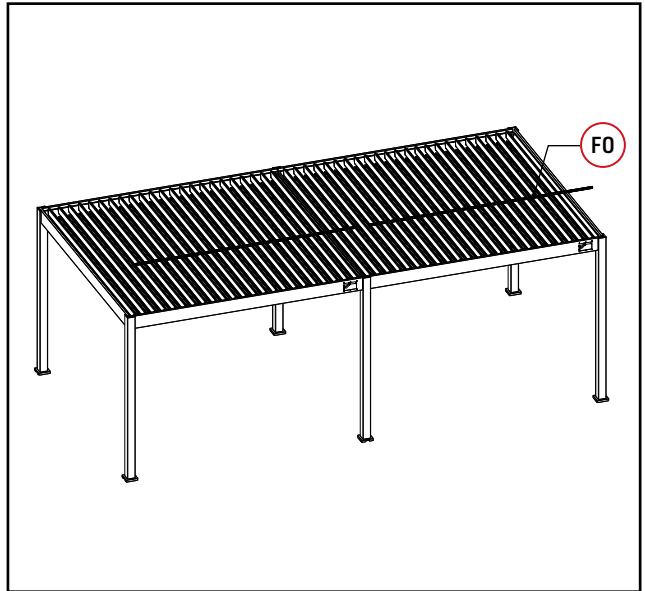

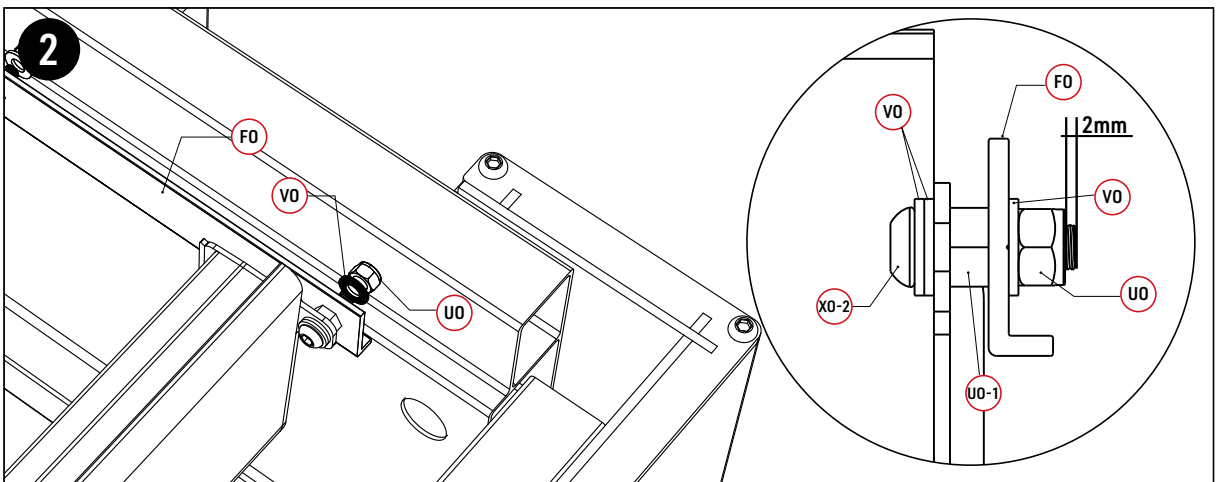
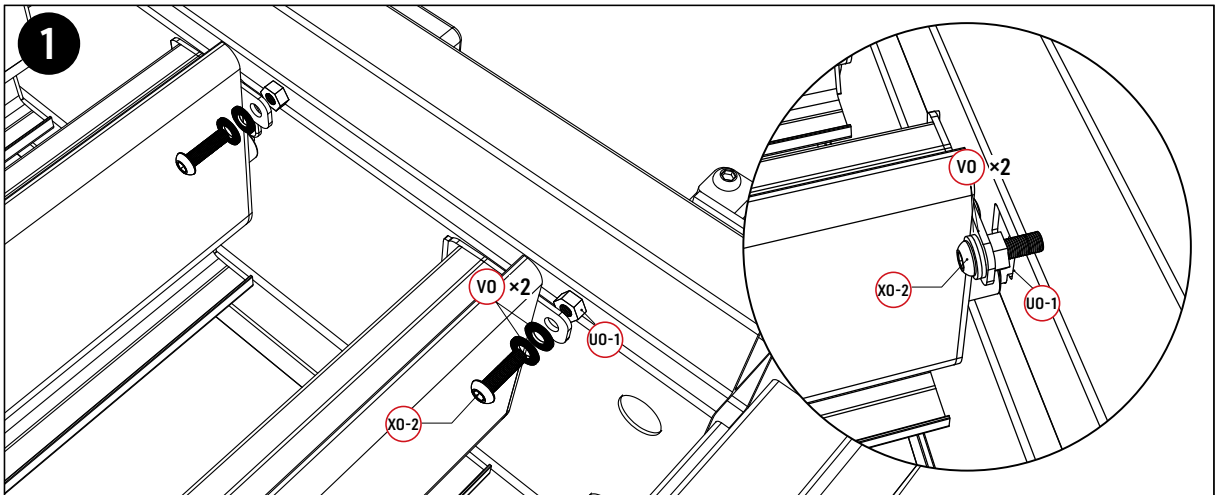

Install the connecting bar



Step 3: Install louvers & Connection

3-8

Parts

RO		24
TO	 10x80	24

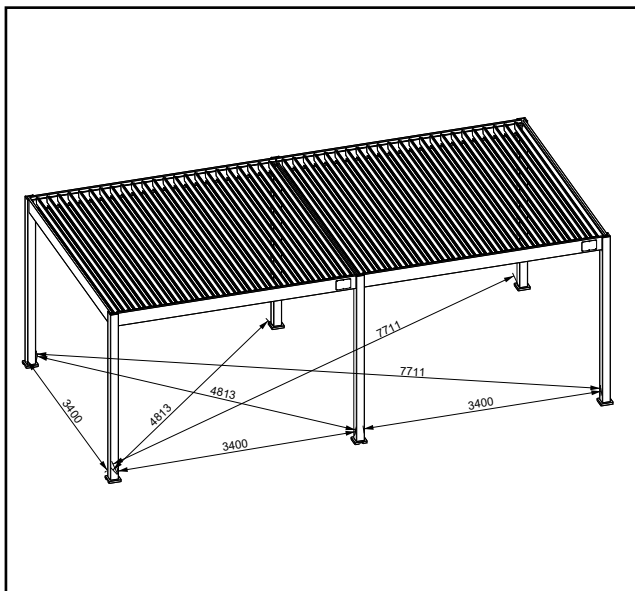

Cover the screw head with plastic caps

1

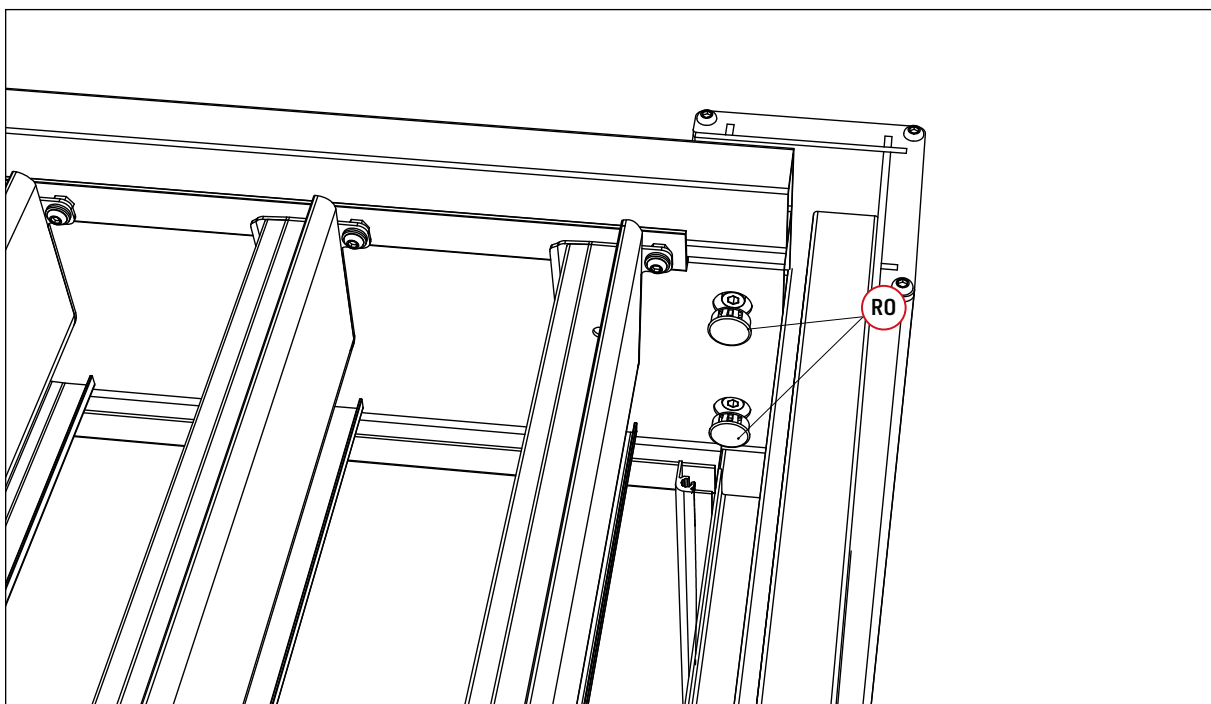

2

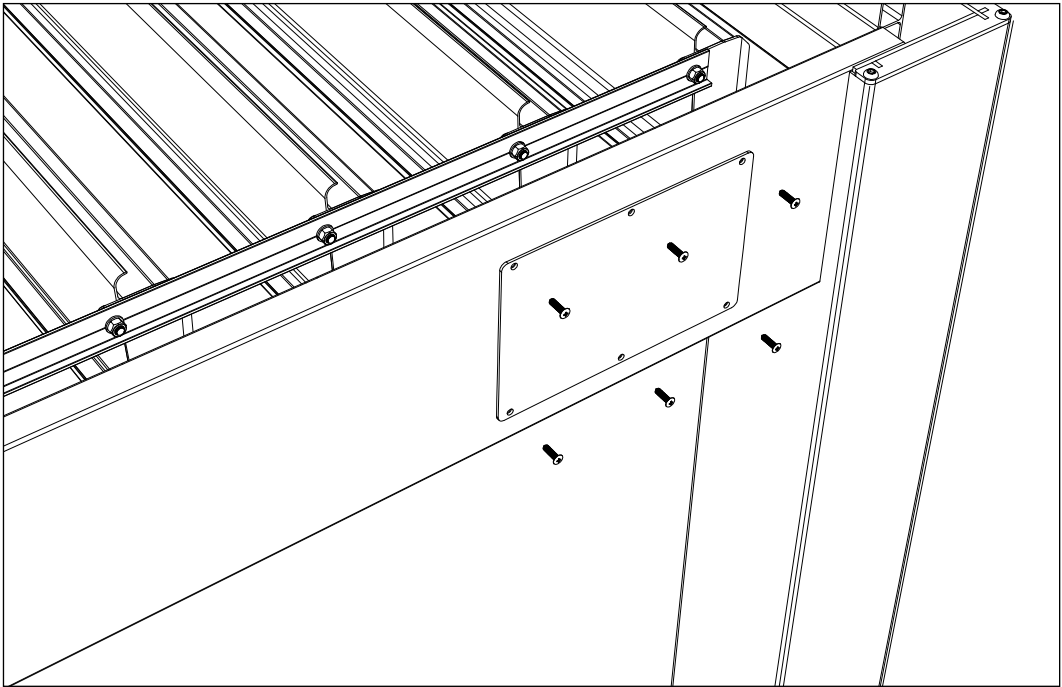



3

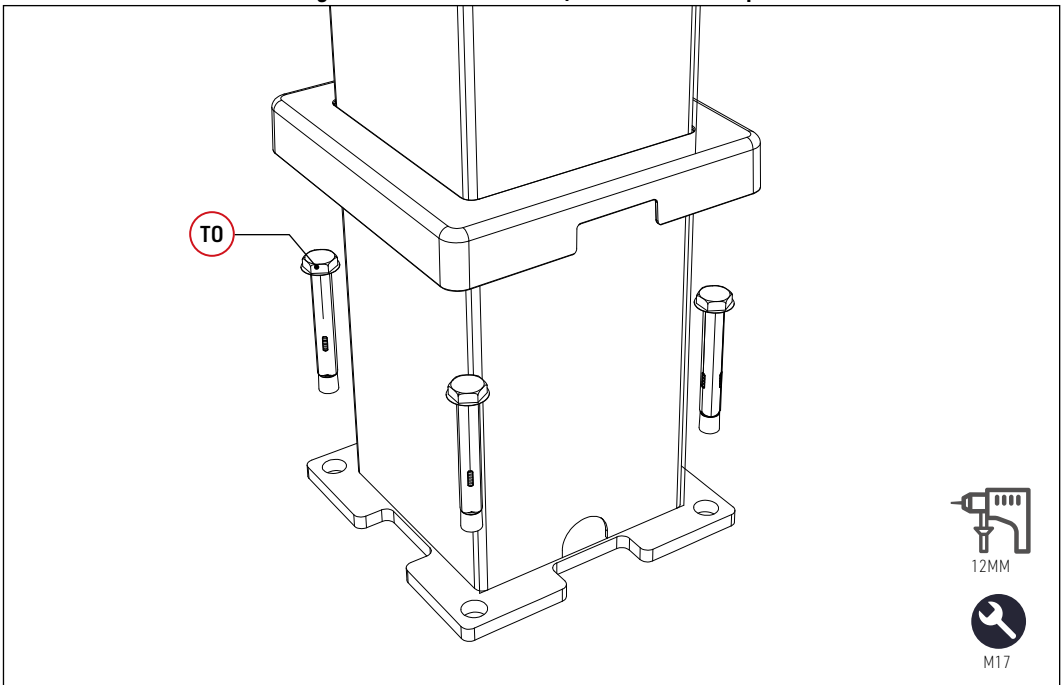

Please check all footing dimension are correct, then fix all base plates.

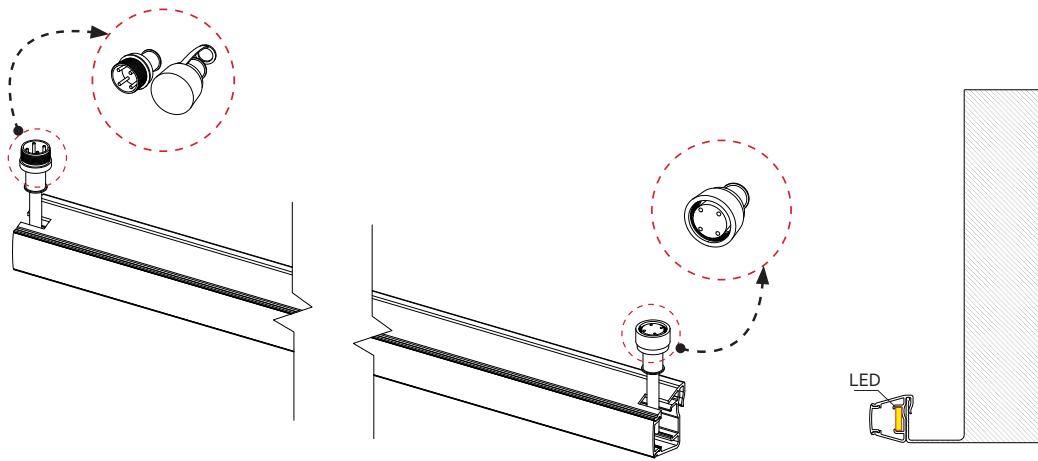



Reference	Parts	Quantity
L-C1	 LED Controller	1

FOR LED



For the connection of the electric controller, please refer to the installation instructions for the electric pergola

placed in the cavity of the horizontal edge beam.

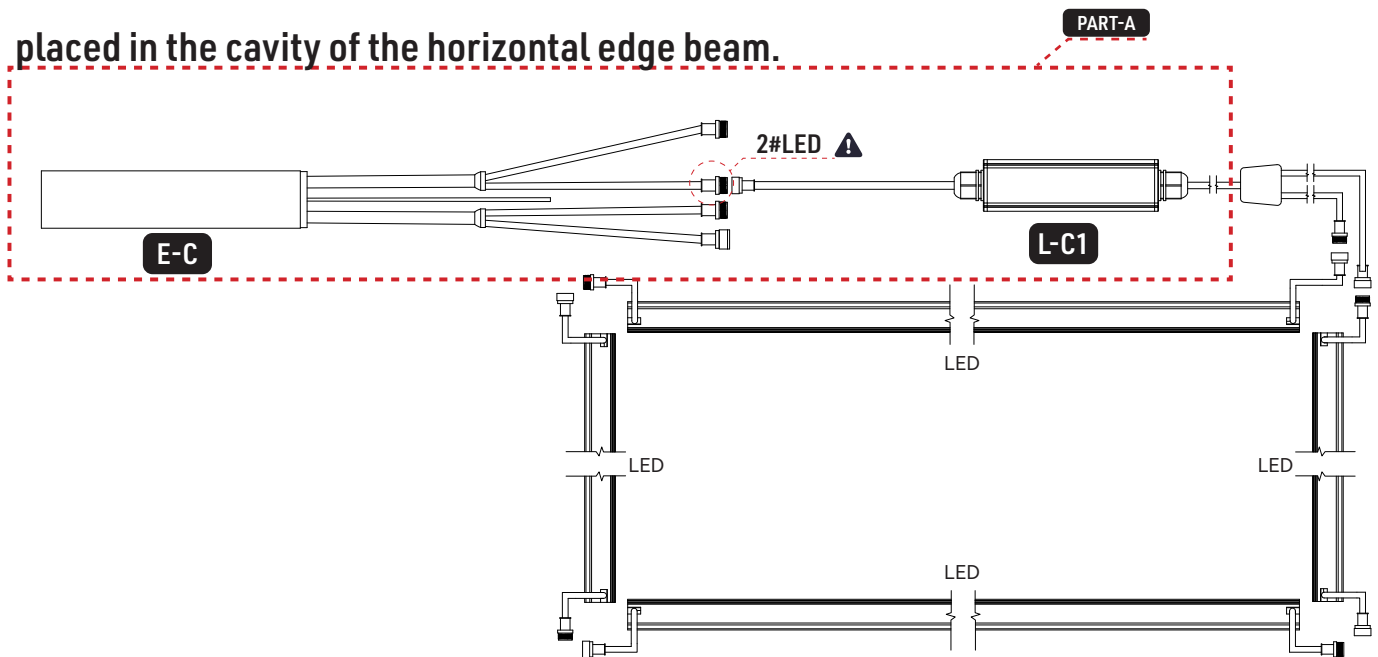



Please follow installation manuals of motorized pergola, insure the correct position of transformer and connector.

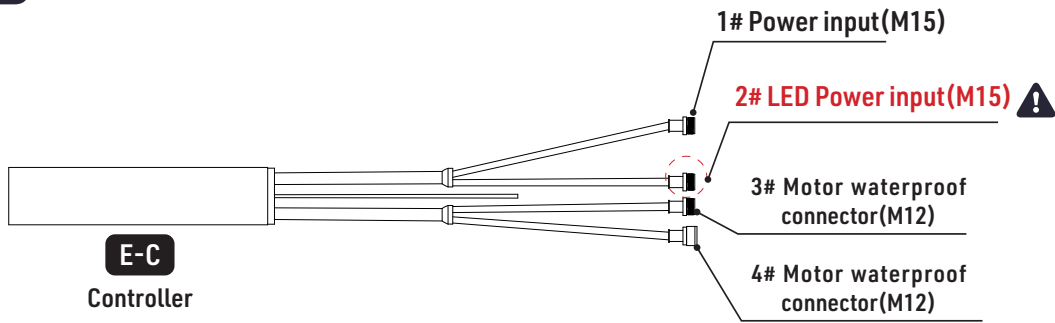

Connect LED controller to Transformer (PART-A) firstly, then place it in cavity of beam.

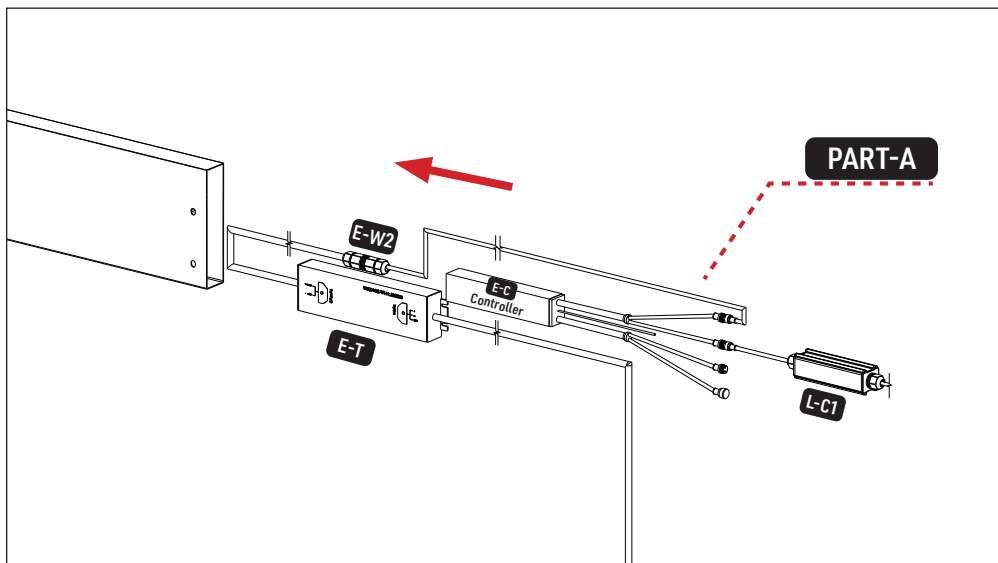

The wire of transformer go through post and wire come out from drain, "INPUT" connect home power, "OUTPUT" connect LED .

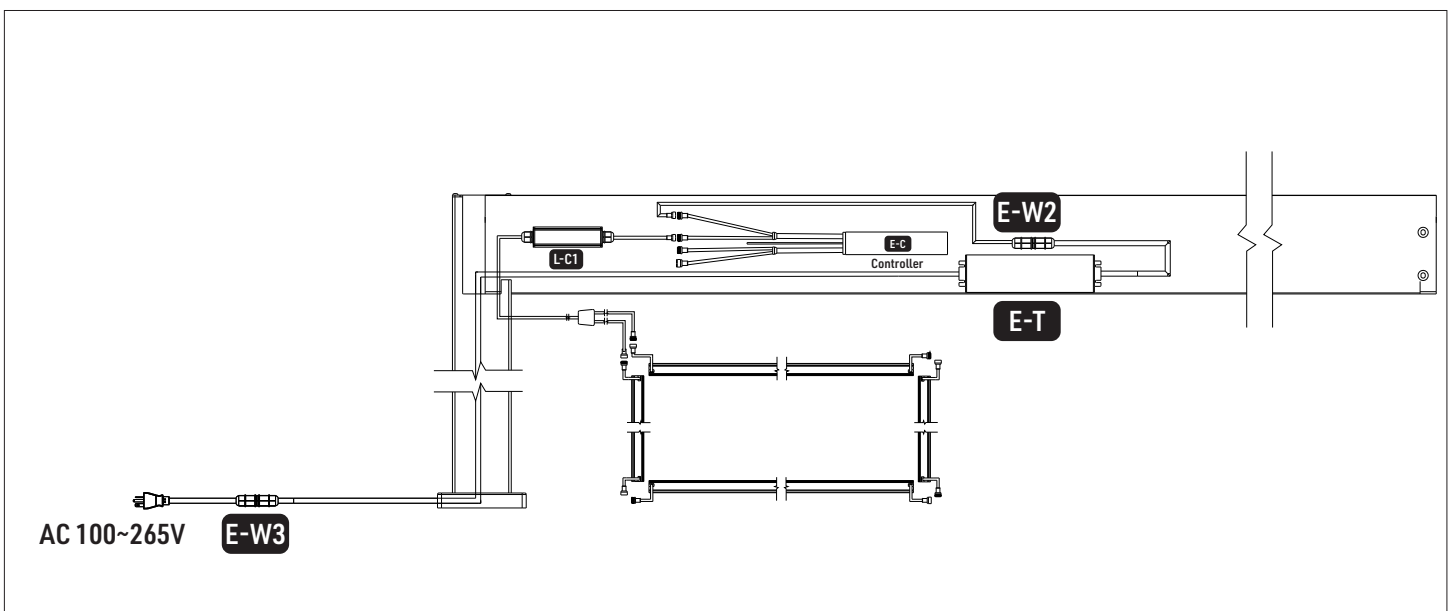

Tuya APP network connection

Please download the corresponding tuya smart/smart life app according to your region.

Press and hold Match/Set key for 2s, or push twice Match/Set key fastly, clear previous network connection, enter Smart config mode, the purple LED indicator fast flash, the output LED will flash 10 times.

Repeat power on and off for 5 consecutive times, also clear previous network connection, enter Smart config mode, the output LED will flash 10 times.

If Tuya APP network connection succeed, the RUN LED indicator will stop flash purple and change to red. In Tuya APP, you can find RGB device.



Smart life APP



Tuya Smart

Tuya APP interface

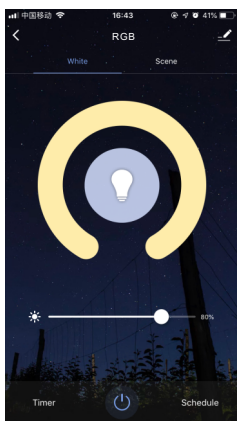

White interface

Touch brightness slide to adjust white brightness.

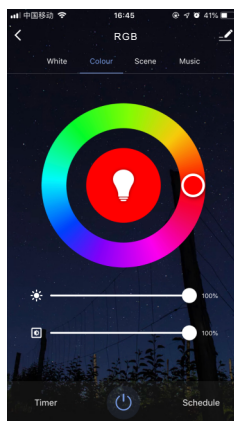

Colour interface

Touch color wheel to adjust static RGB color. Touch brightness slide to adjust color brightness. Touch saturation slide to adjust color saturation, namely gradient from the current color to white (RGB mixed).

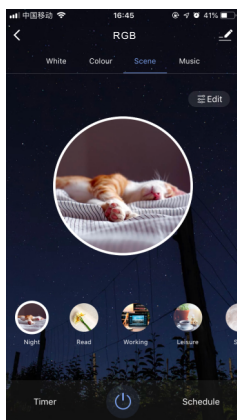

Scene interface

The 1-4 scene is static color for all light type. The inner color of these scene can be editable.

The 5-8 scene is dynamic mode, such as green fade in and fade out, RGB jump, 6 color jump, 6 color smooth.

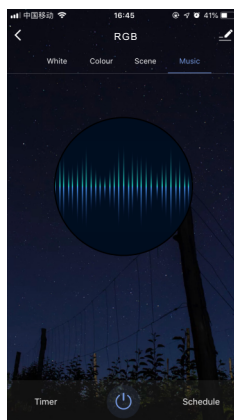

Music, Timer, Schedule

The music play can use smart phone music player or micro-phone as music signal input.

The Timer key can turn on or turn off light in the next 24 hours.

The Schedule key can add multiple timers to turn on or turn off light according to different time periods.

Match remote control (Optional)

End user can choose the suitable match/delete ways. Two options are offered for selection:

Use the Match key

Match:

Short press match key,
immediately press on/off key (single zone remote)
or zone key (multiple zone remote) on the remote.
The LED indicator fast flash a few times means match is successful.

Delete:

Press and hold match key for 20s,
The LED indicator fast flash a few times means all matched remotes
were deleted.

Use Power Restart

Match:

Switch off the power, then switch on power, repeat again.
Immediately short press on/off key (single zone remote) or zone key
(multiple zone remote) 3 times on the remote.
The light blinks 3 times means match is successful.

Delete:

Switch off the power, then switch on power, repeat again.
Immediately short press on/off key (single zone remote) or zone key
(multiple zone remote) 5 times on the remote.
The light blinks 5 times means all matched remotes were deleted.

Dynamic mode list

No.	Name	No.	Name
1	RGB jump	6	RGB fade in and out
2	RGB smooth	7	Red fade in and out
3	6 color jump	8	Green fade in and out
4	6 color smooth	9	Blue fade in and out
5	Yellow cyan purple smooth	10	White fade in and out

Installation precautions

1. The products shall not be stacked, the distance should be $\geq 20\text{cm}$, so as not to affect lifespan of the products due to poor heat dissipation.
2. The product shall not be installed close to the switching power supply with an interval of $\geq 20\text{cm}$ to avoid radiation interference of the switching power supply.
3. The installation height shall be $\geq 1\text{m}$ from the floor to avoid shortening the remote control distance due to too weak reception signal.
4. The products are not allowed to be close to or covered by metal objects, with an interval of $\geq 20\text{cm}$ to avoid signal attenuation and shorten the remote distance.
5. Avoid installation at the corner of the wall or the corner of the beam, with an interval of $\geq 20\text{cm}$ to avoid signal interference.