

*Montageanleitung  
Assembly instructions*



**rügen**

*Strandkorb | Beach chair*

Art. 40194



Montageanleitung  
Assembly instructions



**rügen**

Strandkorb | Beach chair













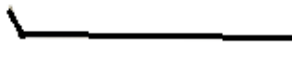

Art. 40194

A		1pc	B		1pc
C1		1pc	C2		1pc
D		1pc	E		1pc
F1		1pc	F2		1pc
G		1pc	H		2pc
I		2pc	J		1pc
K		2pc	L		1pc
M		1pc	N		2pc
O		2pc	P		2pc

**rügen**

Strandkorb | Beach chair

Art. 40194

a	 5 × 45mm	2pc	b	 41cm	3pc
c		2pc	d		2pc
e		2pc	f	 6 × 45mm	20pc
g	 33cm	4pc	h		4pc
i	 3.5 × 25mm	12pc	j		2pc
k	 3.5 × 30mm	10pc	l	 6 × 40mm	2pc
m		4pc	n		2pc
tool		1pc	tool		1pc

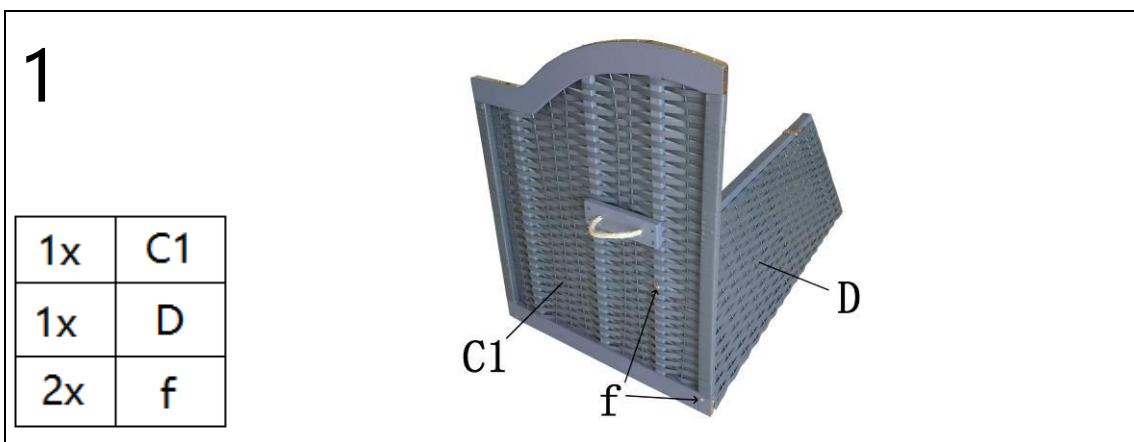

acamp ist eine eingetragene Marke der beo-Garden AG

HVI GmbH & Co. KG | Zur Herrlichkeit 16 / B64 | D-48231 Warendorf | Telefon +49 2581 63602-0 | Fax +49 2581 62800 | acamp@hvi-beo.de | www.acamp.de

**rügen**

Strandkorb | Beach chair

Art. 40194

2

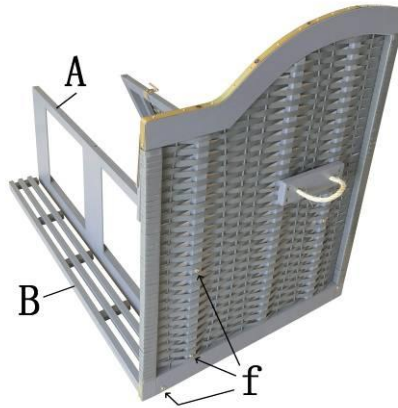

1x	A
1x	B
3x	f

3

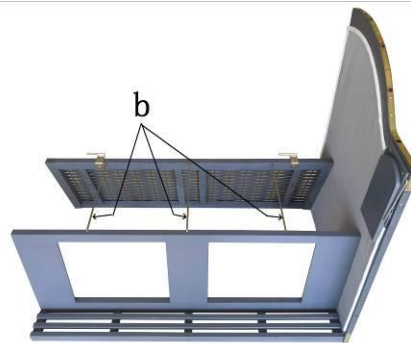

3x	b
----	---

4

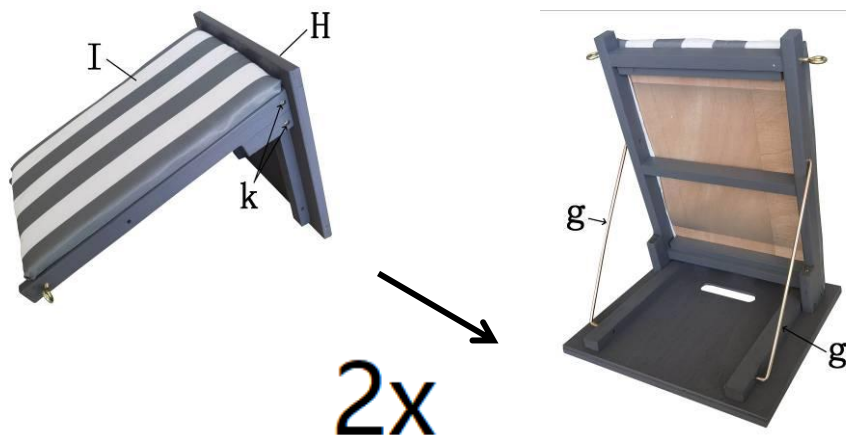

2x	H
2x	I
8x	k
4x	g

**rügen**

Strandkorb | Beach chair

Art. 40194

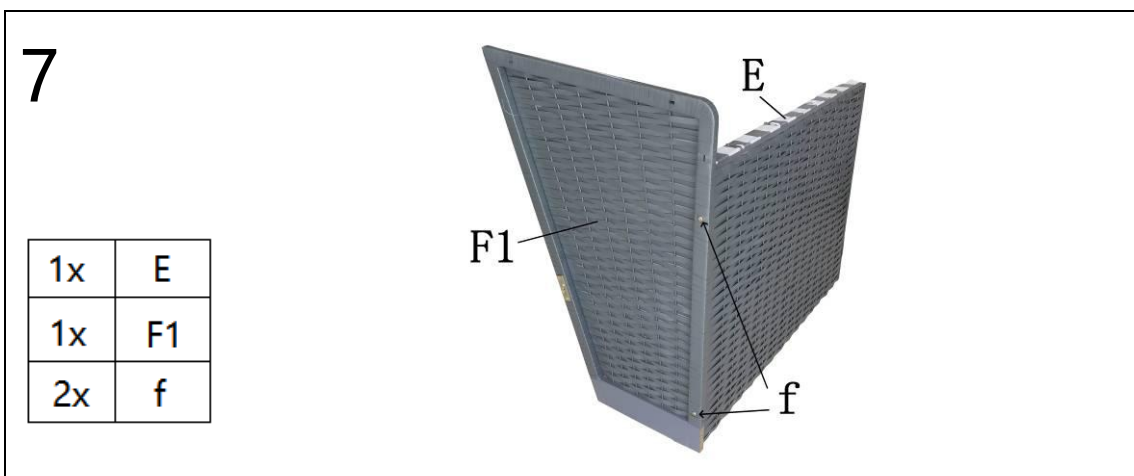
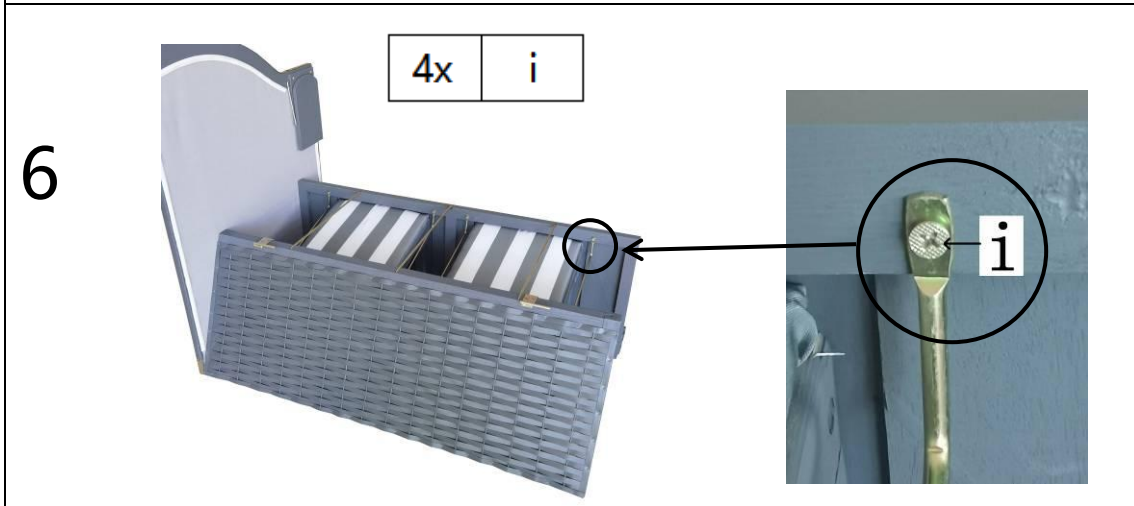
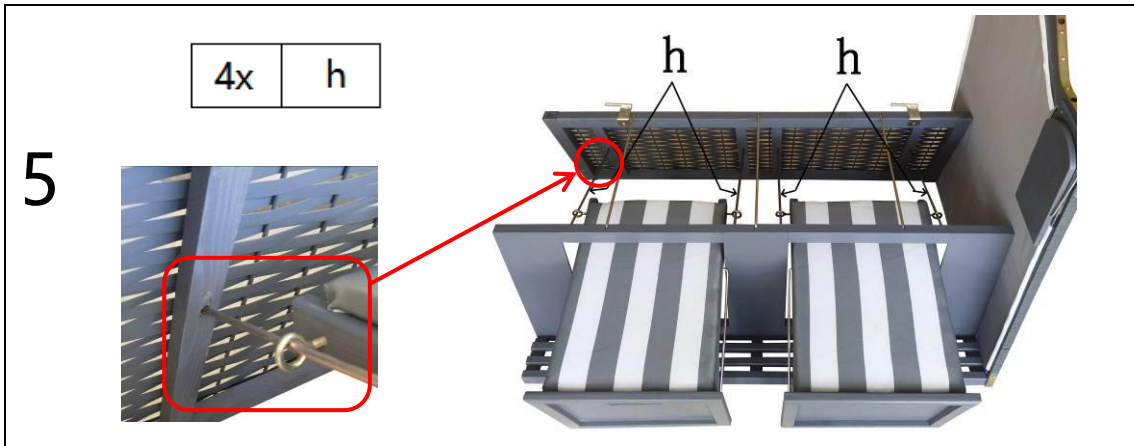

**rügen**

Strandkorb | Beach chair

Art. 40194

8

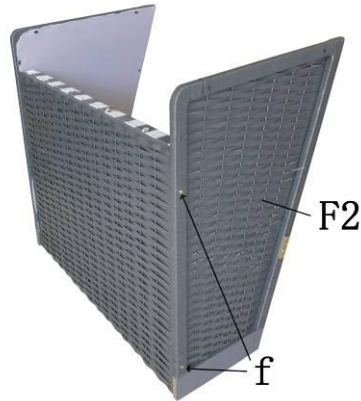

1x	F2
2x	f

9

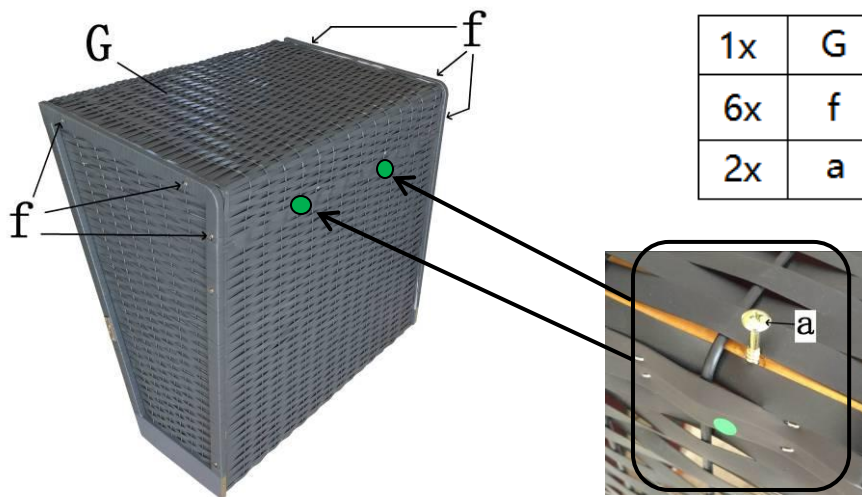

1x	G
6x	f
2x	a

10

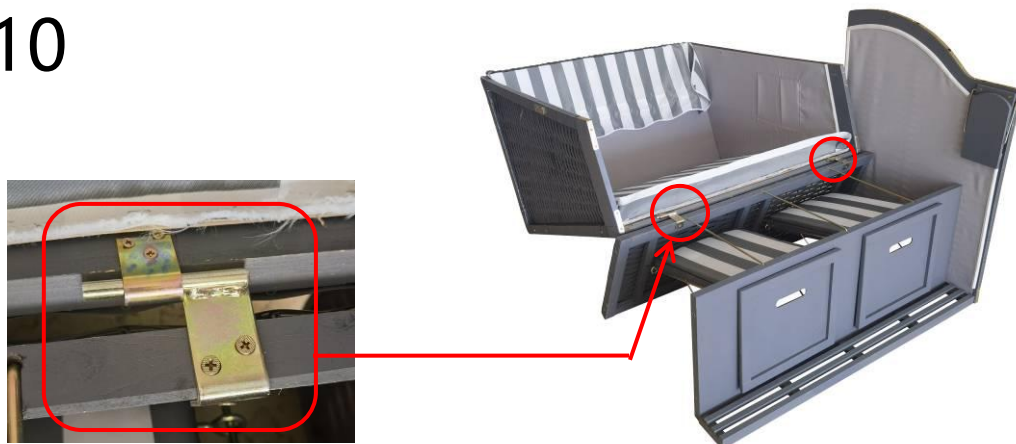

**rügen**

Strandkorb | Beach chair

Art. 40194

# 11

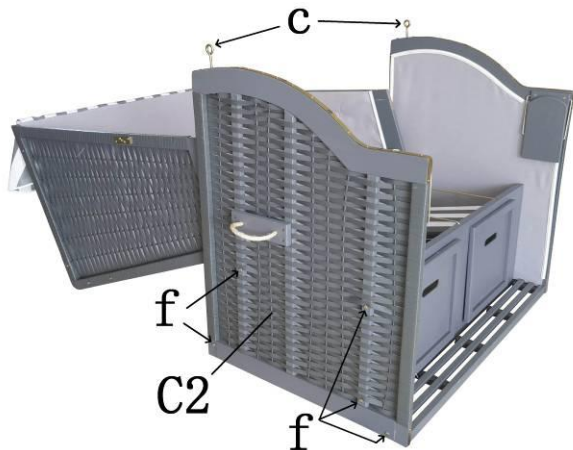

1x	C2
5x	f
2x	c

# 12

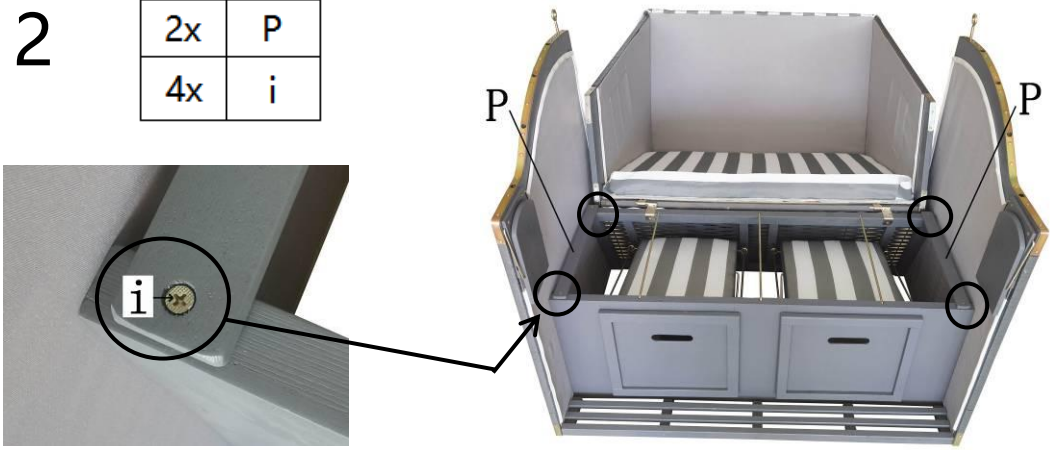

2x	P
4x	i

# 13

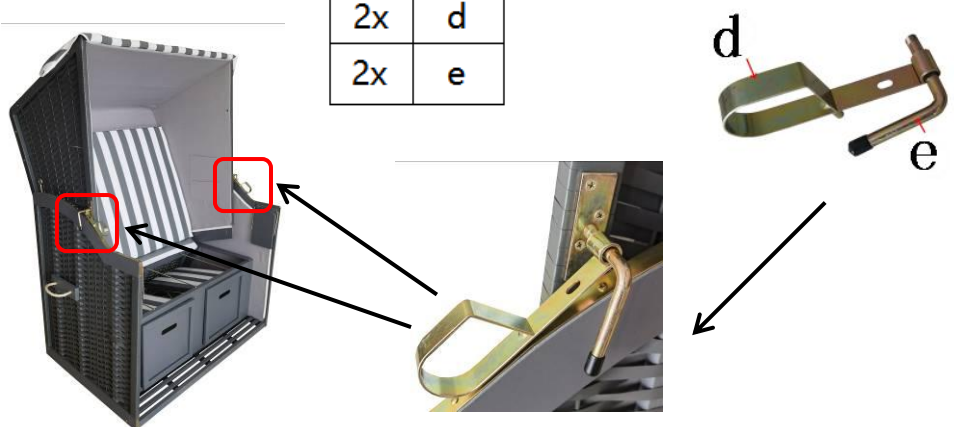

2x	d
2x	e

**rügen**

Strandkorb | Beach chair

Art. 40194

14

1x	J
2x	K
2x	k

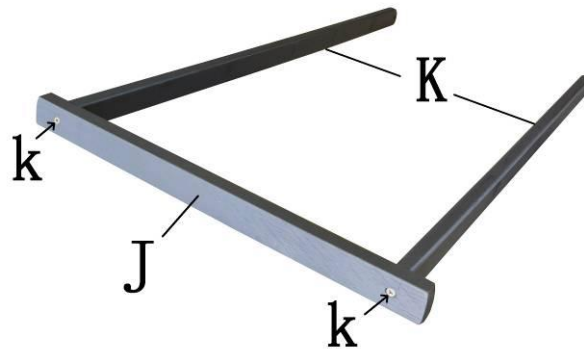

15

2x	j
4x	i

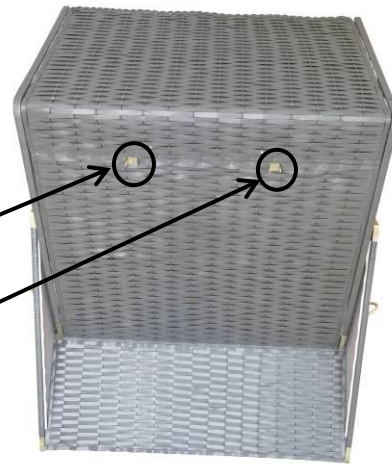
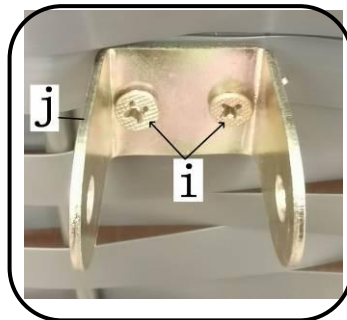

16

2x	l
2x	n

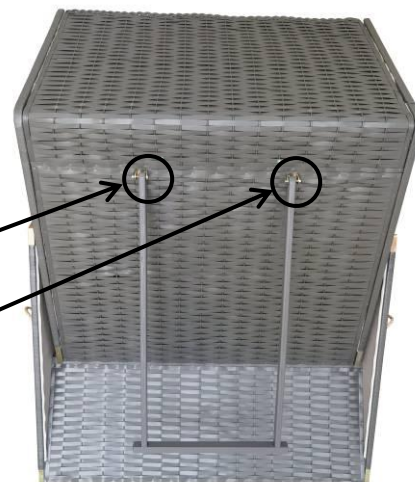

**rügen**

Strandkorb | Beach chair

Art. 40194

17

1x	L
2x	f
2x	m

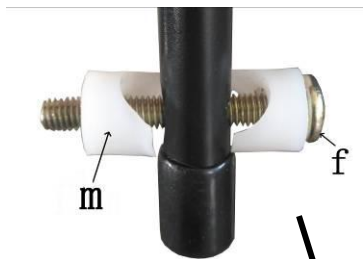

18

1x	M
2x	N
2x	O

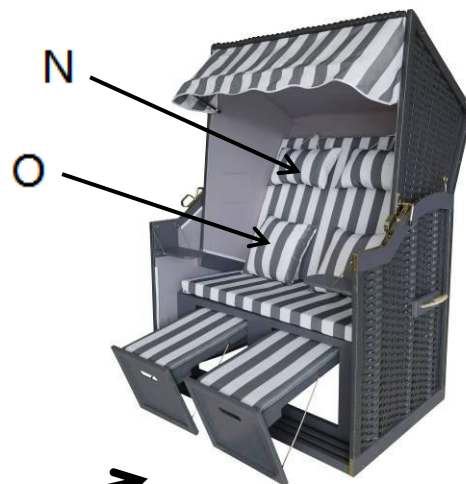
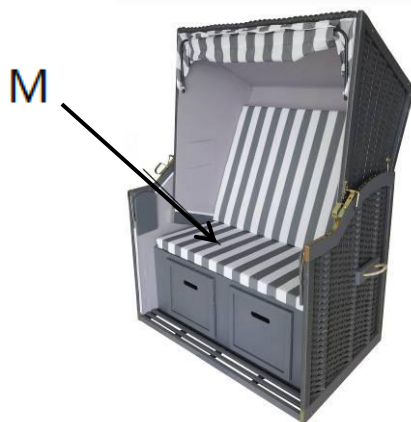

***Pflegehinweise:***

Zum Entfernen leichter Verschmutzungen verwenden Sie ein feuchtes Tuch. Bei stärkerer Verschmutzung reinigen Sie Ihr acamp Produkt mit einer milden Seifenlauge. Verwenden Sie keine scharfen und scheuernden Reiniger oder Lösungsmittel. Reinigen Sie Ihre acamp Outdoormöbel nie mit einem Hochdruckreiniger. Holz zur Vermeidung von Schimmelbefall und Verzug regelmäßig ölen.

***Sicherheitshinweise:***

Verwenden Sie Ihre acamp Outdoormöbel nur gemäß ihrer Bestimmung. Der Hersteller haftet nicht für Schäden, die durch unsachgemäßen Gebrauch verursacht werden.

***Care instructions:***

Use a damp cloth to remove light soiling. For heavier soiling you should clean your acamp product using a mild soapy solution. Do not use any sharp or scouring cleaners or solvents. Never use a pressure washer to clean your acamp outdoor furniture. Oil the wood regularly to avoid mold growth and warping.

***Safety information:***

Only use your acamp outdoor furniture for its intended purpose. The manufacturer takes no responsibility for damage caused through inappropriate use.

***Conseils d'entretien:***

Utilisez un chiffon humide pour éliminer les légères salissures. En cas de fort encrassement, nettoyez votre produit acamp avec un produit nettoyant doux. N'utilisez pas de produit nettoyant ou de solvant récurant ou agressif. Ne nettoyez jamais vos meubles d'extérieur acamp avec un nettoyeur à haute pression. Huilez le bois régulièrement pour éviter la formation de moisissures et le gauchissement.

***Consignes de sécurité:***

Utilisez vos meubles d'extérieur acamp uniquement conformément l'usage prévu. Le fabricant n'est pas responsable des dommages liés à une utilisation non conforme.

***Indicazioni di manutenzione:***

Per rimuovere piccoli depositi di sporcizia usate un panno umido. Per depositi maggiori pulite invece il vostro articolo acamp con liscivia di sapone delicata. Non usate detersivi o solventi abrasivi o aggressivi. Mai lavare i mobili outdoor acamp con idropulitrice. Oliare regolarmente il legno per evitare la crescita di muffe e deformazioni.

***Indicazioni di sicurezza:***

Usate i mobili outdoor acamp solo secondo la loro destinazione d'uso. Il produttore non si assume alcuna responsabilità per danni derivanti da un uso improprio.