

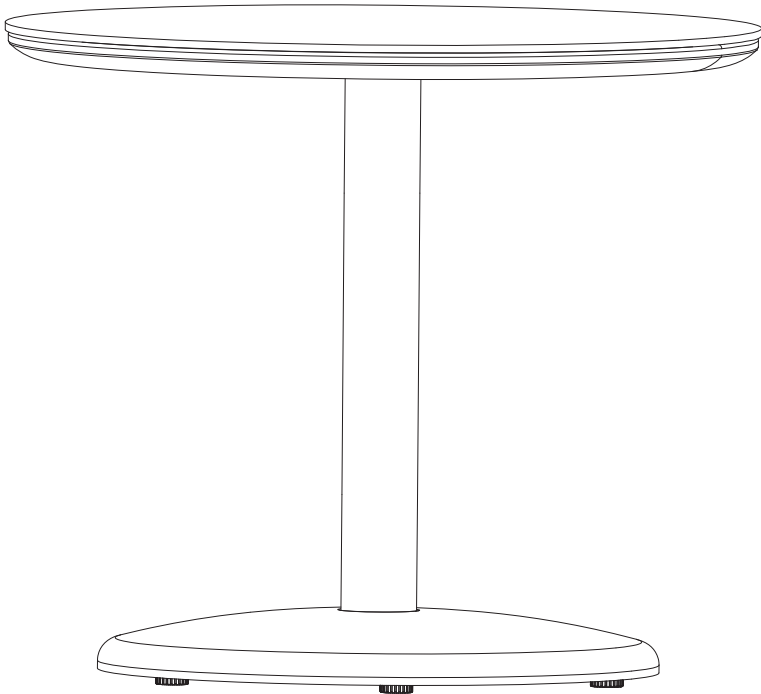

## **Desert/154443/154439**

Table/Tabelle/Table/Tabela  
/Mesa/Tafel



**EN: IMPORTANT, PLEASE READ CAREFULLY AND RETAIN FOR FUTURE REFERENCE  
PRODUCT WARRANTY**

**1. Warranty Coverage**

• MWH GmbH ("supplier") guarantees that Royal Garden furniture products sold in the EU and UK and coated with THERMOSINT ("product") will not rust through for 5 years from the purchase date.  
• If defects occur, the supplier will repair or replace parts at their discretion, free of charge.

• The warranty applies to private end users in Europe and UK and is nontransferable without proof of purchase. Coverage excludes assembly and wear parts (e.g., screws, wheels, foot caps).

**2. Exclusions and Limitations**

This warranty does not apply in cases of misuse, extreme environmental exposure, damage caused by non-replacement of wear parts, incompatible accessories, unauthorized modifications, improper storage or failure to follow care instructions [as example: damage caused by, chemical reactions]. Claims for damages beyond repair/replacement are excluded. Legal rights through retailers are unaffected.

**3. Claim Process**

To file a claim, the original purchase receipt must be presented.  
• In writing to: MWH GmbH, Blindeisenweg 23, 41468 Neuss, Germany  
• Or through [www.royal-garden.com/support](http://www.royal-garden.com/support)

**4. Remedies & Product Care Requirements For safe use and to maintain warranty validity:**

- Use the product only as outdoor furniture.
- Check and tighten components regularly.
- Avoid contact with hot objects, plasticizers, and aggressive cleaning agents.
- Do not pressure wash; use warm water, mild soap, and soft cloths.
- During frost months, store indoors or protect it appropriately.
- For seaside use, clean monthly.

**EN: IMPORTANT, PLEASE READ CAREFULLY AND RETAIN FOR FUTURE REFERENCE  
PRODUCT WARRANTY**

**1. Warranty Coverage**

• MWH GmbH ("supplier") guarantees that Royal Garden furniture products sold in the EU and UK and coated with THERMOSINT ("product") will not rust through for 5 years from the purchase date.

• If defects occur, the supplier will repair or replace parts at their discretion, free of charge.

• The warranty applies to private end users in Europe and UK and is nontransferable without proof of purchase. Coverage excludes assembly and wear parts (e.g., screws, wheels, foot caps).

**2. Exclusions and Limitations**

This warranty does not apply in cases of misuse, extreme environmental exposure, damage caused by non-replacement of wear parts, incompatible accessories, unauthorized modifications, improper storage or failure to follow care instructions [as example: damage caused by, chemical reactions]. Claims for damages beyond repair/replacement are excluded. Legal rights through retailers are unaffected.

**3. Claim Process**

To file a claim, the original purchase receipt must be presented.  
• In writing to: MWH GmbH, Blindeisenweg 23, 41468 Neuss, Germany  
• Or through [www.royal-garden.com/support](http://www.royal-garden.com/support)

**4. Remedies & Product Care Requirements For safe use and to maintain warranty validity:**

- Use the product only as outdoor furniture.
- Check and tighten components regularly.
- Avoid contact with hot objects, plasticizers, and aggressive cleaning agents.
- Do not pressure wash; use warm water, mild soap, and soft cloths.
- During frost months, store indoors or protect it appropriately.
- For seaside use, clean monthly.

**EN: IMPORTANT, PLEASE READ CAREFULLY AND RETAIN FOR FUTURE REFERENCE  
PRODUCT WARRANTY**

**1. Warranty Coverage**

• MWH GmbH ("supplier") guarantees that Royal Garden furniture products sold in the EU and UK and coated with THERMOSINT ("product") will not rust through for 5 years from the purchase date.

• If defects occur, the supplier will repair or replace parts at their discretion, free of charge.

• The warranty applies to private end users in Europe and UK and is nontransferable without proof of purchase. Coverage excludes assembly and wear parts (e.g., screws, wheels, foot caps) must be presented.

• In writing to: MWH GmbH, Blindeisenweg 23, 41468 Neuss, Germany  
• Or through [www.royal-garden.com/support](http://www.royal-garden.com/support)

**4. Remedies & Product Care Requirements For safe use and to maintain warranty validity:**

- Use the product only as outdoor furniture.
- Check and tighten components regularly.
- Avoid contact with hot objects, plasticizers, and aggressive cleaning agents.
- Do not pressure wash; use warm water, mild soap, and soft cloths.
- During frost months, store indoors or protect it appropriately.
- For seaside use, clean monthly.

**EN: IMPORTANT, PLEASE READ CAREFULLY AND RETAIN FOR FUTURE REFERENCE  
PRODUCT WARRANTY**

**1. Warranty Coverage**

• MWH GmbH ("supplier") guarantees that Royal Garden furniture products sold in the EU and UK and coated with THERMOSINT ("product") will not rust through for 5 years from the purchase date.

• If defects occur, the supplier will repair or replace parts at their discretion, free of charge.

• The warranty applies to private end users in Europe and UK and is nontransferable without proof of purchase. Coverage excludes assembly and wear parts (e.g., screws, wheels, foot caps).

**2. Exclusions and Limitations**

This warranty does not apply in cases of misuse, extreme environmental exposure, damage caused by non-replacement of wear parts, incompatible accessories, unauthorized modifications, improper storage or failure to follow care instructions [as example: damage caused by, chemical reactions]. Claims for damages beyond repair/replacement are excluded. Legal rights through retailers are unaffected.

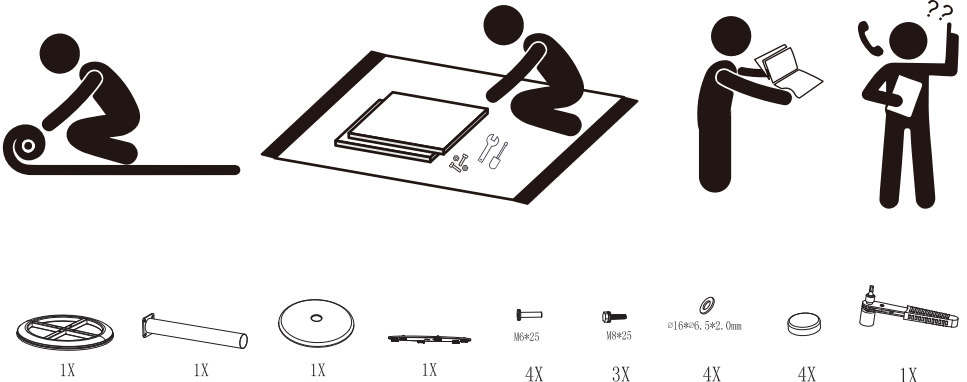

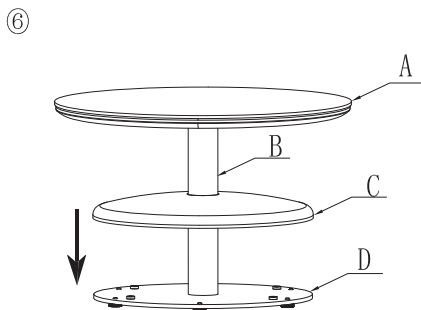
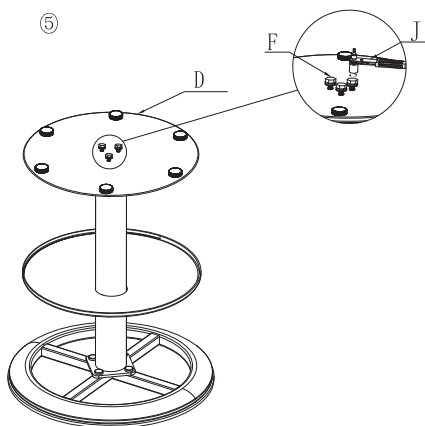
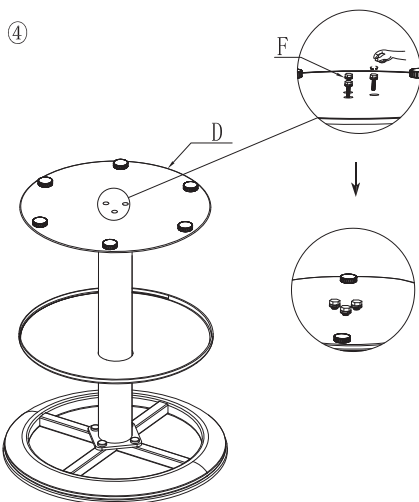
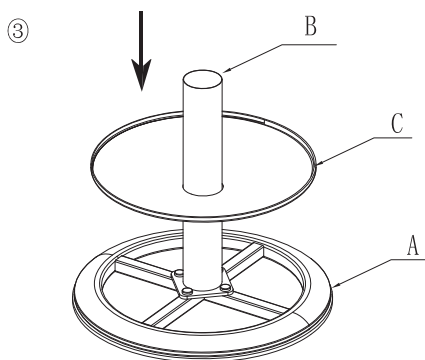
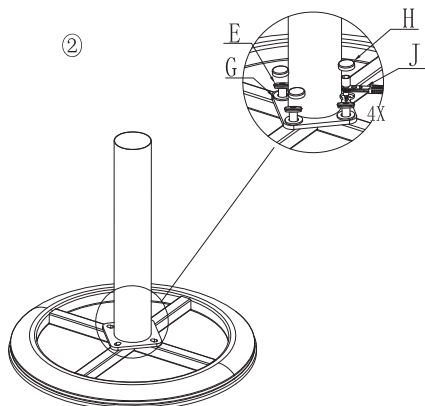
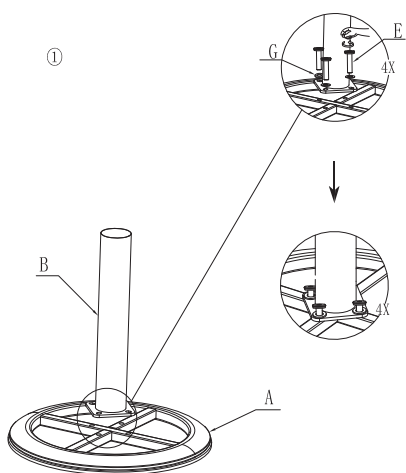

MWH GmbH  
 Blindeisenweg 23,  
 41468 Neuss, Germany  
 info@mwhgmbh.de  
 www.royal-garden.com  
 Made in China

