

# elektrische Pergola Aluminium

MONTAGEANLEITUNG

**3.6x4**  
ELE+LED



# Wir schätzen Ihren Kauf unserer Pergola.

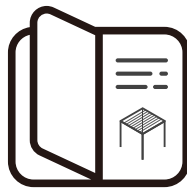

## Montageanleitung

Diese Anleitung bietet Ihnen eine Schritt-für-Schritt-Anweisung zur Montage und Pflege Ihrer Pergola, damit Sie jahrelange Freude und zuverlässige Nutzung genießen können.

Achten Sie darauf, alle Schritte sorgfältig zu befolgen, da eine falsche Installation zu schweren Verletzungen führen kann.

---

### **WICHTIG:**

Zur Sicherheit aller Personen ist es entscheidend, diese Anweisungen zu befolgen. Bitte bewahren Sie diese Anweisungen zur zukünftigen Referenz auf.

Kinder und Personen mit Behinderungen oder geringer Erfahrung dürfen das Gerät benutzen, wenn sie ordnungsgemäß beaufsichtigt oder geschult wurden und die potenziellen Risiken verstehen

Kinder dürfen nicht mit dem Gerät spielen. Reinigungs- und Wartungsarbeiten dürfen von Kindern nur unter der Aufsicht eines Erwachsenen durchgeführt werden.

Diese Pergola ist für den privaten Außenbereich konzipiert und bietet Schutz vor direkter Sonneneinstrahlung, Blendung und Hitze.

Jede Nutzung oder Änderung, die nicht in dieser Anleitung beschrieben ist, gilt als unsachgemäß und kann erhebliche Risiken für Benutzer und Eigentum darstellen. Solche Handlungen führen zum Erlöschen der Produktgarantie.

# VOR DER INSTALLATION

## BEREITEN SIE ALLE BENÖTIGTEN WERKZEUGE VOR

Um Ihre Pergola ordnungsgemäß und sicher zu montieren, stellen Sie sicher, dass Sie die folgenden Werkzeuge und Zubehörteile zur Hand haben, da diese nicht im Lieferumfang enthalten sind.



## ÜBERPRÜFEN SIE AUF FEHLENDE TEILE:

Bevor Sie mit der Installation beginnen, überprüfen Sie, ob alle notwendigen Teile für die Montage Ihrer e-Motion vorhanden sind. Kontrollieren Sie sorgfältig, ob die Anzahl der Teile mit dem von Ihnen gekauften Modell übereinstimmt.

Sollten Teile fehlen, wenden Sie sich bitte an den Kundendienst, bevor Sie mit der Installation fortfahren.

## BEREITEN SIE DIE TEILE FÜR JEDEN SCHRITT VOR:

Im Installationsabschnitt der Anleitung werden in jedem Schritt die benötigten Teile und deren Mengen angegeben. Wir empfehlen, die erforderlichen Teile im Voraus für jeden Schritt bereitzulegen. Dies spart Zeit und erleichtert den Montageprozess. Um Beschädigungen der lackierten Oberflächen zu vermeiden, legen Sie die Teile nach Möglichkeit auf Karton oder eine andere weiche Unterlage.

## WÄHLEN SIE EINEN GEEIGNETEN STANDORT:

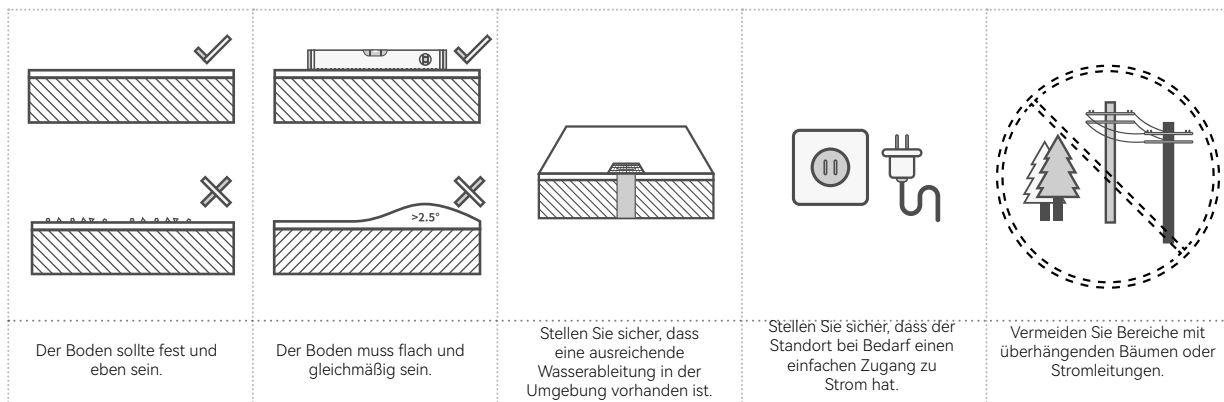

## WARNUNG:

Viele Terrassen oder Patios werden mit einem leichten Gefälle gebaut, um Regenwasser vom Haus oder anderen Strukturen abzuleiten. Für die ordnungsgemäße Installation der Pergola ist jedoch eine absolut ebene Fläche erforderlich. Kleine Kieselsteine oder unebener Boden können verhindern, dass die Pergola sicher verankert wird.

Wird die Pergola auf einer unebenen Fläche installiert, kann dies die Funktion der Zubehörkomponenten beeinträchtigen und zum Erlöschen der Produktgarantie führen. Gegebenenfalls müssen die Höhen des Untergrundes angepasst werden, um eine korrekte Montage zu gewährleisten.

## BEREITEN SIE DAS FUNDAMENT VOR:

















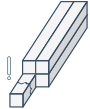
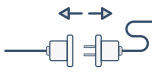
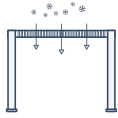
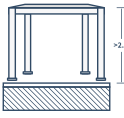

Stellen Sie sicher, dass Sie folgende Punkte beachten:

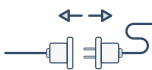



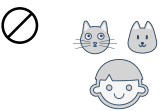
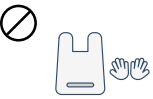
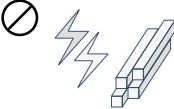

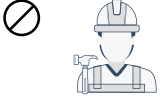
Überprüfen Sie unterirdische Rohre und Kabel (kontaktieren Sie die zuständigen lokalen Behörden, bevor Sie graben). Klären Sie mit den örtlichen Behörden, ob eine Baugenehmigung erforderlich ist. Wenn Sie sich für ein Betonfundament entscheiden, konsultieren Sie einen renommierten Fachbetrieb.

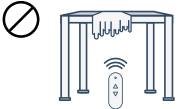
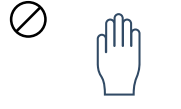
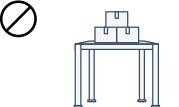
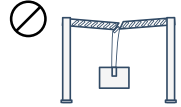

# WICHTIGE SICHERHEITSHINWEISE

Um die Sicherheit aller Personen während der Installation und Nutzung der Pergola zu gewährleisten, ist es unerlässlich, die nachstehenden Sicherheitsrichtlinien zu befolgen.

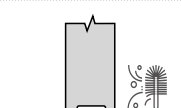
	Die Pergola muss auf einer flachen, ebenen Oberfläche platziert und gesichert werden.		Tragen Sie während der Montage stets geeignete Arbeitsschuhe, Handschuhe und einen Augenschutz.
	Bei der Verwendung von Elektrowerkzeugen oder einer Leiter beachten Sie stets die Sicherheitsanweisungen des Herstellers.		Tragen Sie stets Schutzkleidung, um das Verletzungsrisiko im Falle eines Sturzes zu minimieren.
	Stellen Sie sicher, dass die Pergola den örtlichen Bauvorschriften und Richtlinien entspricht.		Betreten Sie die Lamellen nicht.
	Verwenden Sie nur Leitern und Gerüste, die das erforderliche Gewicht tragen können.		Überprüfen Sie die Pergola vor jeder Nutzung auf sichtbare Schäden. Falls Schäden festgestellt werden, stellen Sie die Nutzung sofort ein und wenden Sie sich an autorisiertes Fachpersonal zur Reparatur.
	Entfernen Sie alle überflüssigen Kabel und trennen Sie nicht benötigte Geräte, bevor Sie den Antrieb installieren.		Um Schäden zu vermeiden, stellen Sie die Lamellen bei Schnee oder windigen Bedingungen in die vertikale Position.
	Unabgedeckte bewegliche Teile, die eine Gefahr darstellen, sollten in einer Höhe von mehr als 2,5 Metern über dem Boden oder einer anderen Oberfläche installiert werden, die Zugang zu ihnen ermöglichen könnte.		Verwenden Sie stets vom Hersteller zugelassene Ersatzteile.
	Um Schäden an der Pergola zu vermeiden, entfernen Sie regelmäßig Laub und Fremdkörper von den Lamellen und aus den Führungsschienen.		Die elektrische Installation darf nur von zertifiziertem Fachpersonal gemäß den geltenden Vorschriften durchgeführt werden.
	Trennen Sie vor der Installation alle elektrischen Anschlüsse vom Stromnetz.		Bedienen Sie die Pergola per Fernsteuerung nur, wenn Sie die beweglichen Teile deutlich sehen können.
	Die Stromversorgung für elektrische Pergolen darf nur von einem lizenzierten Elektrofachbetrieb installiert werden.		Wenn der Motor wiederholt Öffnungs- und Schließzyklen durchläuft, kann er in den Überhitzungsschutzmodus wechseln. Er kehrt in den Normalbetrieb zurück, sobald er abgekühlt ist.
	Halten Sie Kinder und Haustiere vom Montagebereich fern, bis die Installation vollständig abgeschlossen ist.		Entsorgen Sie alle Plastikbeutel verantwortungsvoll und bewahren Sie sie außerhalb der Reichweite von Kindern auf.
	Halten Sie einen sicheren Abstand zu Stromleitungen, insbesondere beim Umgang mit Metallteilen.		Vermeiden Sie die Montage der Pergola bei windigen oder nassen Witterungsbedingungen.
	Im Falle eines beschädigten Netzkabels darf der Austausch nur durch den Hersteller, einen Kundendiensttechniker oder ähnlich qualifiziertes Fachpersonal erfolgen.		Lagern Sie keine heißen Gegenstände, wie frisch benutzte Grills oder Lötbrenner, unter oder in der Nähe der Pergola.

	Um Schäden am Antrieb der Lamellen zu vermeiden, betätigen Sie den Dachmechanismus nicht bei Frost oder Eis.		Halten Sie Kleidung und Körperteile von der Pergola fern, um ein Einklemmen in den beweglichen Teilen zu vermeiden.
	Halten Sie Gegenstände von den Lamellen fern.		Es ist nicht erlaubt, Gegenstände an der Pergola aufzuhängen, da dies zu schweren Schäden führen kann.
	Bevor Sie Änderungen am Design oder an der Konfiguration der Anlage vornehmen, konsultieren Sie den Hersteller oder einen autorisierten Vertreter.		Halten Sie Kinder von den fest installierten Bedienelementen fern und bewahren Sie Fernbedienungen außerhalb ihrer Reichweite auf.
	Die Garantie erlischt und der Betriebsmechanismus kann beschädigt werden, wenn nicht originale Marken-Zubehörteile installiert werden.		Wichtig: Reinigen Sie die Entwässerungslöcher der Säulen regelmäßig mit einer weichen Bürste, um Verstopfungen und Schäden zu vermeiden.
	Wir garantieren die Widerstandsfähigkeit der Pergola bei Windgeschwindigkeiten bis zu 80 km/h.		Wir garantieren die Widerstandsfähigkeit der Pergola für eine maximale Schneelast von 50 kg/m <sup>2</sup> .

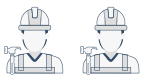

## 2 PERSONEN ERFORDERLICH

Das elektrische Steuerungssystem befindet sich im Hohlraum des Pfostens.



Die Verbindungsstange und die Bürste befinden sich im Hohlraum des Trägers.



Auf der Innenseite des Kartons befindet sich eine Produktverfolgungsnummer (siehe Abbildung unten). Für einen besseren und effizienteren Kundendienst in der Zukunft machen Sie bitte ein Foto der Tracking-Nummer, bevor Sie den Karton entsorgen, und speichern Sie dieses.

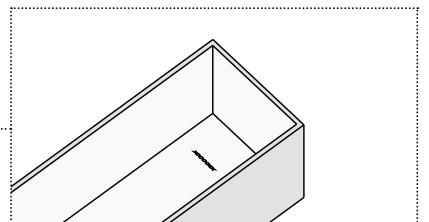
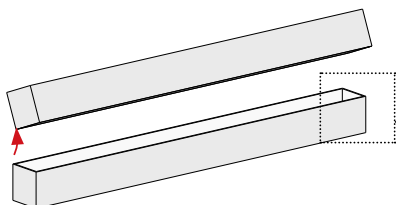

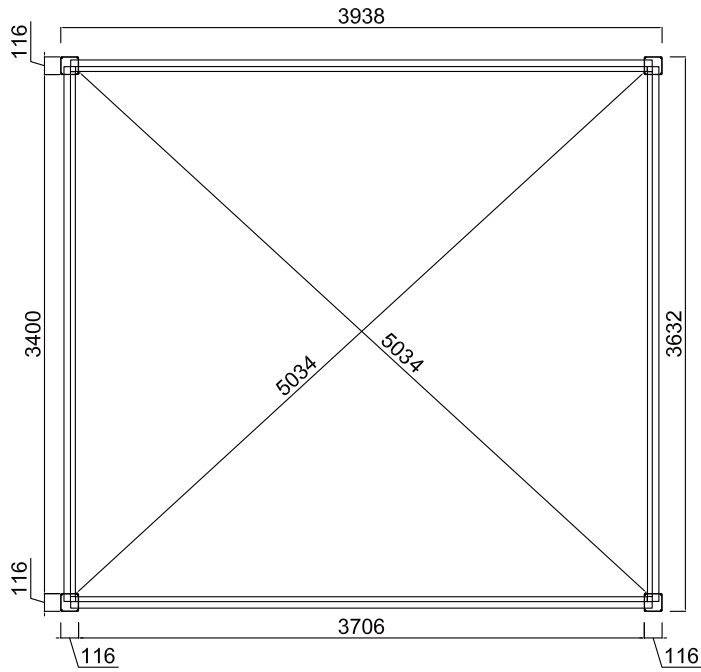

Planmaße



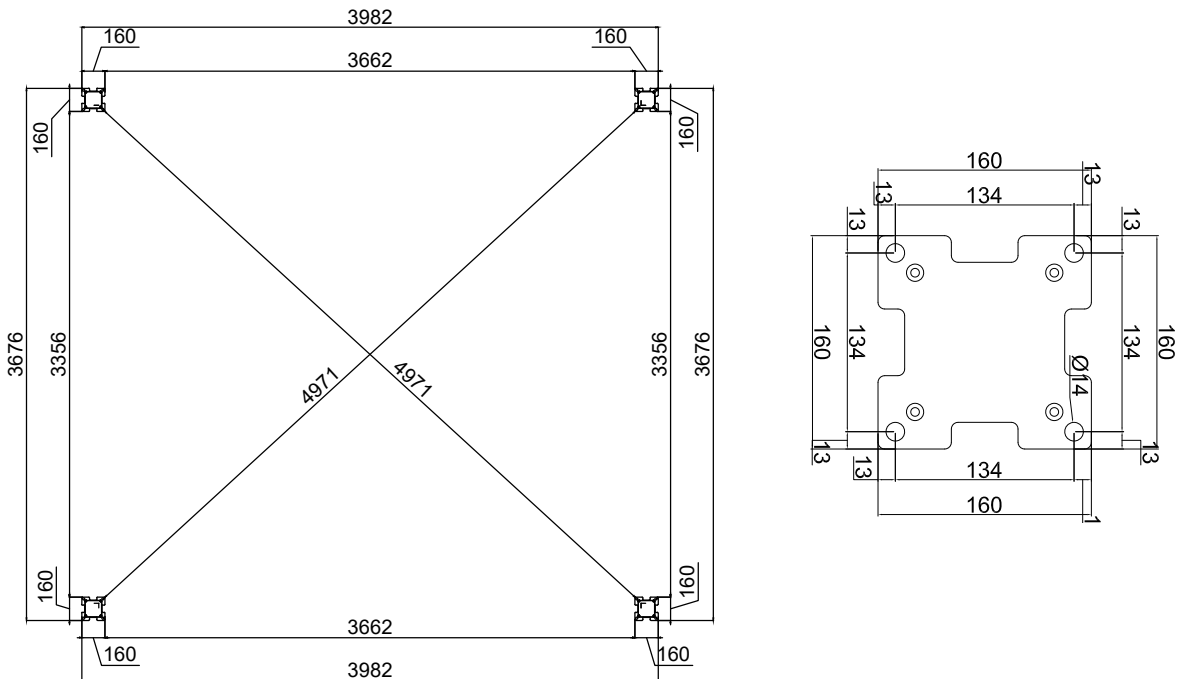



Grundrissplan der Bodenplatte

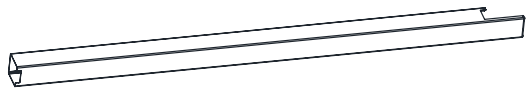





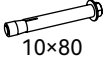

## KARTON 1/5

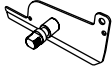
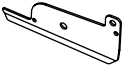
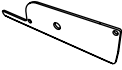
Nr.	Profil	Bild	Masse	Menge
A0			136X136 L=2550mm	2
A0-2			116X116 L=2550mm	2

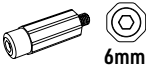





Nr.	Bild	Menge
I0		4
J0		4

Nr.	Bild	Menge
T0	 10x80	16
X0-1	 6x35      4mm	16

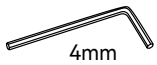
Nr.	Bild	Menge
K0		1
L0		24
L0-1		25
M0		49
M0-1		49
Q0	 6mm	24
R0		24
S0		50



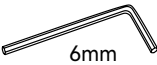



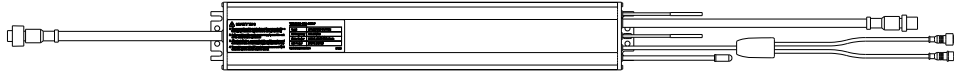
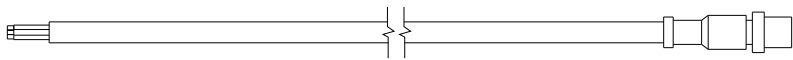
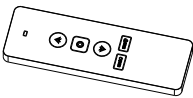
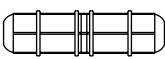



Nr.	Bild	Menge
U0	 lock nut	74
U0-1	 plastic nut	25
U0-3	 M14	1
V0		124
W0	 4x16      PH2	100
X0	 6x40      4mm	49
X0-2	 6x20      4mm	25



## KARTON 1/5

Nr.	Bild	Menge	Nr.	Bild	Menge
Z0-1	 4mm	1	Z0-4	 6mm	1
Z0-2	 4mm	1	Z0-5	 10mm	1
Z0-3	 6mm	1	Z0-6	 PH2	1

Nr.	Bild	Menge
E-A		1
E-B		1
E-CR		1
E-D		1

## KARTON 2/5

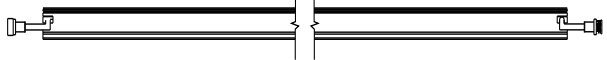

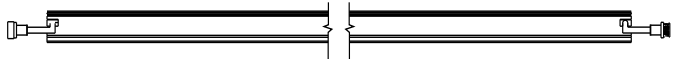
Nr.	Profil	Bild	Masse	Menge
B3			75X195 L=3809mm	1
B0-4			75X195 L=3809mm	1
C0-3			75X195 L=3503mm	1
C0-4			75X195 L=3503mm	1
F0			27X8 L=3650mm	1

Nr.	Profil	Bild	Masse	Menge
LED1			69X78 L=3705mm	2
LED2			69X78 L=3399mm	2

## KARTON 3/5

Nr.	Profil	Bild	Masse	Menge
G0			166X38 L=3464mm	9

## KARTON 4/5

Nr.	Profil	Bild	Masse	Menge
G0			166X38 L=3464mm	9

## KARTON 5/5

Nr.	Profil	Bild	Masse	Menge
G0			166X38 L=3464mm	7

---

Bevor Sie mit der Montage Ihrer Lamellenpergola beginnen, müssen Sie überprüfen, ob alle aufgeführten Teile vorhanden und unbeschädigt sind.

Fehlende Teile müssen innerhalb von 10 Tagen nach der Lieferung gemeldet werden.

Entsorgen Sie die Verpackung nicht, bevor Sie sichergestellt haben, dass das Produkt einwandfrei funktioniert.

## Achtung:

Bitte beachten Sie, dass sich der Auslass an der Abdeckung für die Vorderseite in der vorderen Position befinden muss, während er für die Rückseite spiegelbildlich zur Vorderseite angeordnet ist.

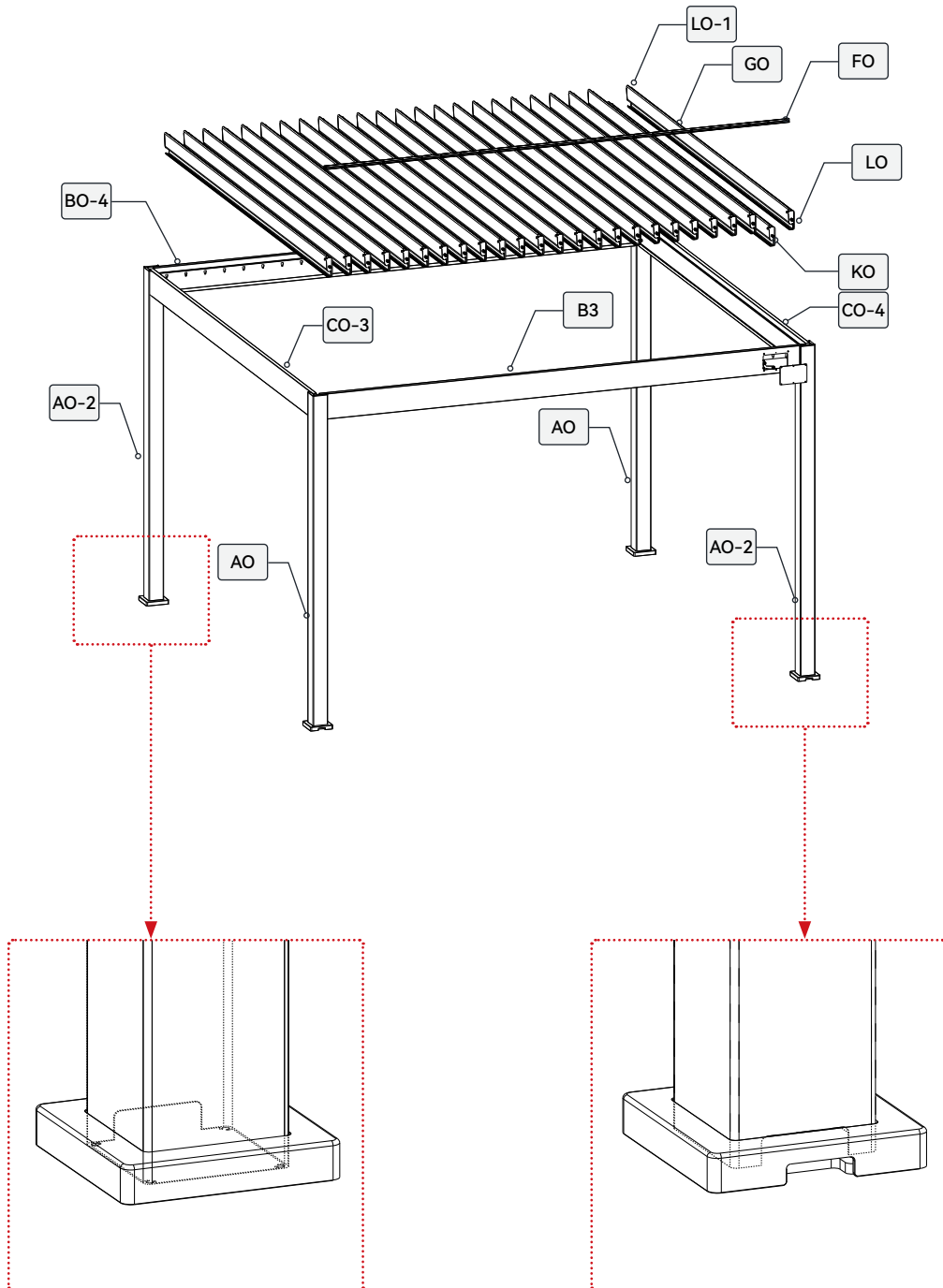



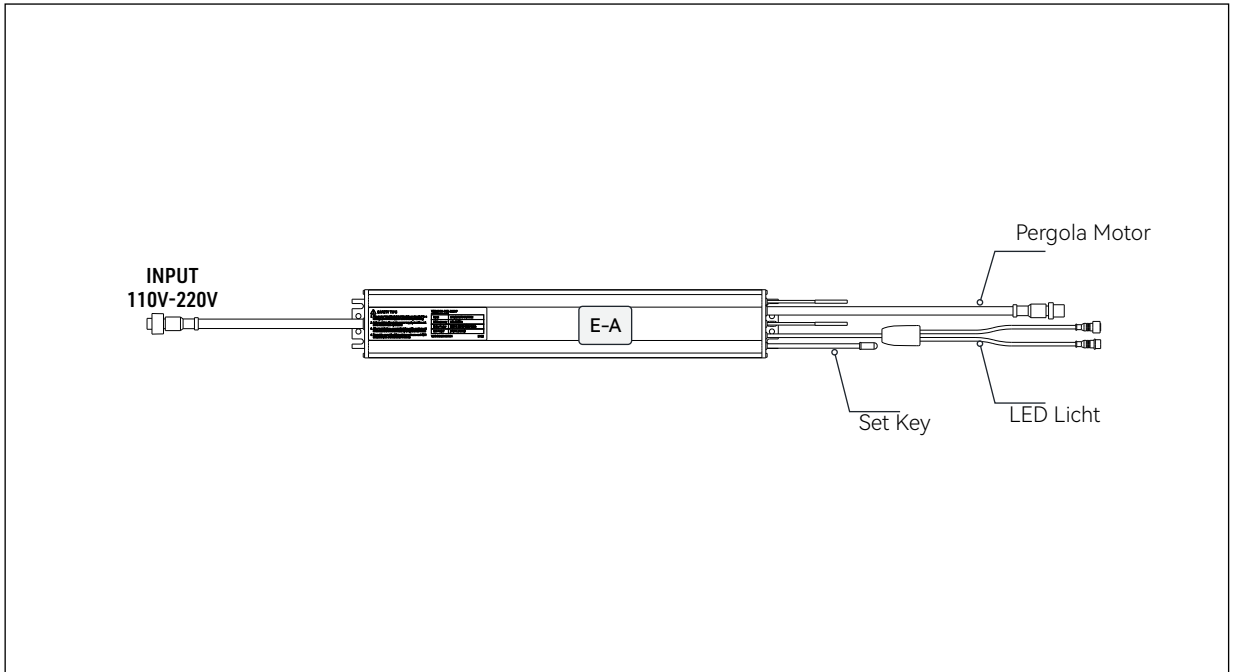

Kabelbild

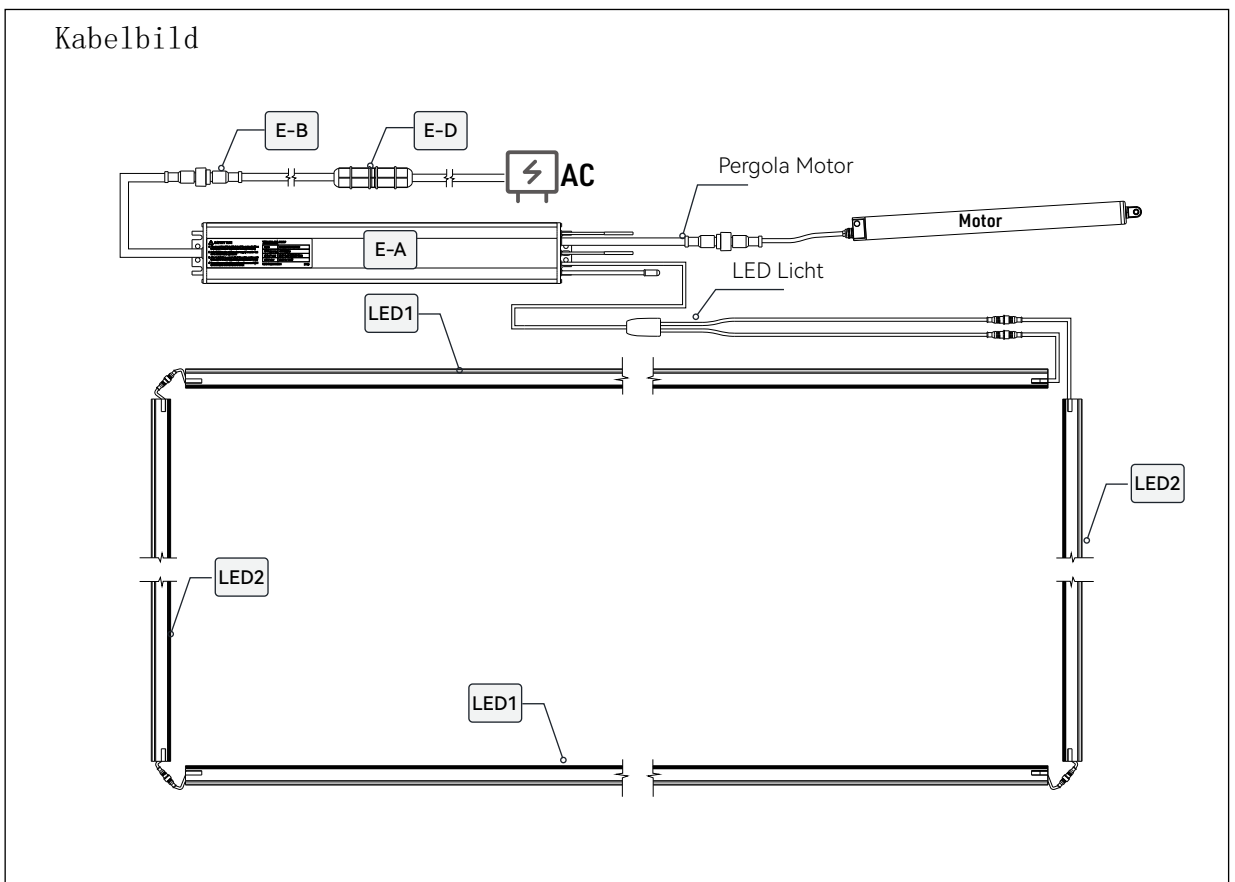

## Achtung:

- Der Controller muss innerhalb des Seitenbalkens installiert werden, wobei das Eingangskabel durch den Pfosten geführt und durch die Entwässerungsöffnung herausgeführt wird.
- Setzen Sie den Controller mindestens 20 cm tief in die Aussparung des Seitenbalkens ein und stellen Sie sicher, dass ein Abstand von 40 mm zum Balkenende eingehalten wird.
- Die Befestigung von Zubehör wird 18 cm vom Balkenende entfernt in den Balken geschraubt.

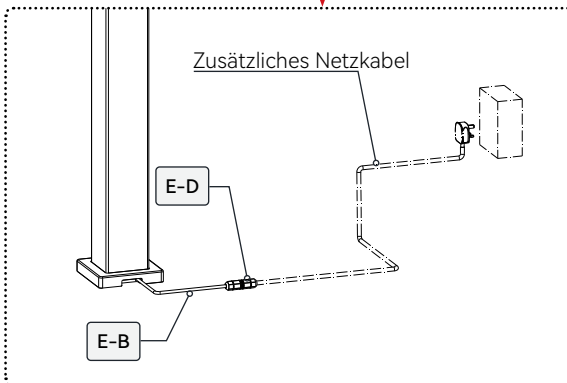
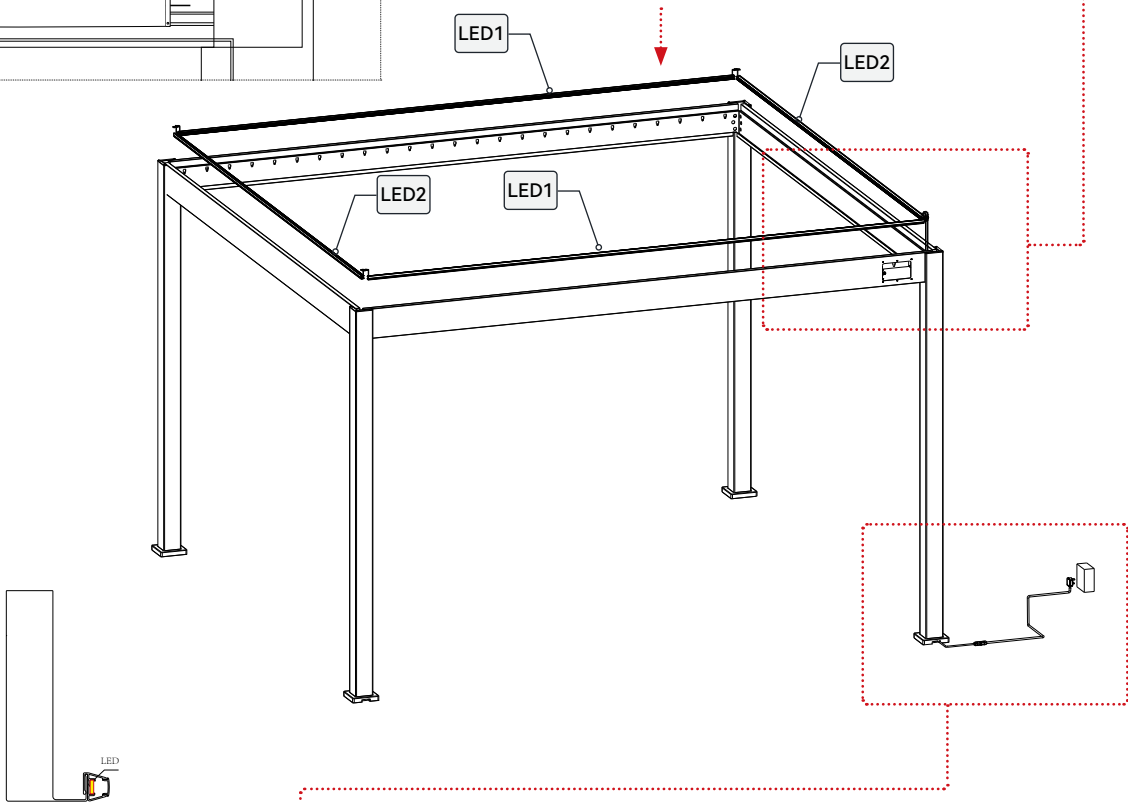
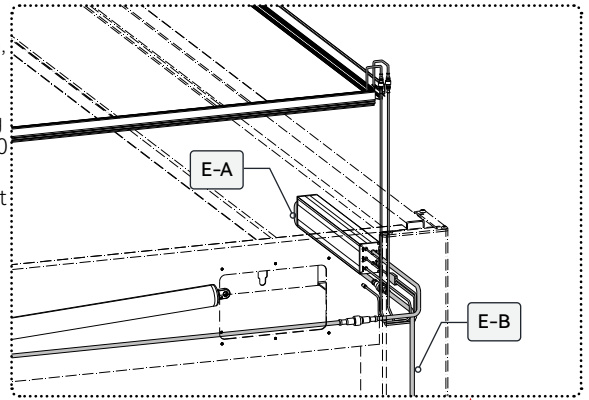
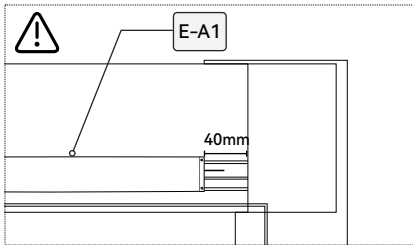











## Achtung:

Bitte wählen Sie das passende Netzkabel entsprechend dem Land, in dem Sie sich befinden, und schließen Sie es mit einem wasserdichten Verbinder an. Dieser Controller unterstützt Spannungen im Bereich von 110V bis 220V.



Am Eingang des Netzteils befinden sich drei Kabel:  
 Braun: Phase (L)  
 Blau: Neutralleiter (N)  
 Gelb-Grün: Schutzleiter (PE)

Die Abbildung zeigt einen manuellen Schraubenschlüssel, der durch einen elektrischen Schraubendreher oder Akkuschauber ersetzt werden kann.

KO		1	MO		49	XO		49	ZO-1		4mm
LO		24	MO-1		49	UO		49	ZO-2		4mm
LO-1		25	VO		49				ZO-5		10mm

## Achtung:

Installieren Sie die Spindeln für die Abdeckung an beiden Enden der Lamellen.

Hinweis: Um ein Brechen der Kunststoffteile (MO) zu vermeiden, reduzieren Sie bitte die Drehkraft des Akkuschaubers beim Schrauben.



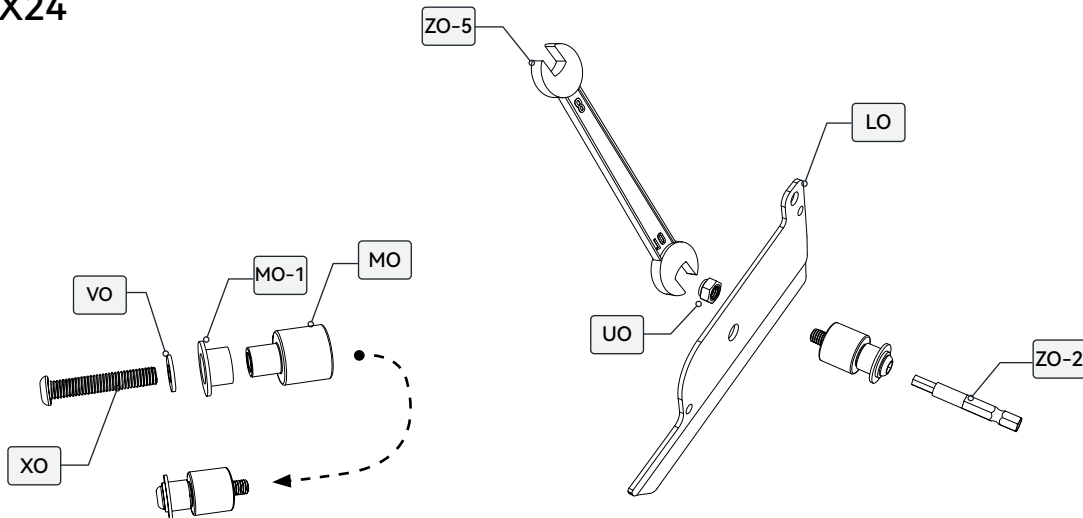

## X24

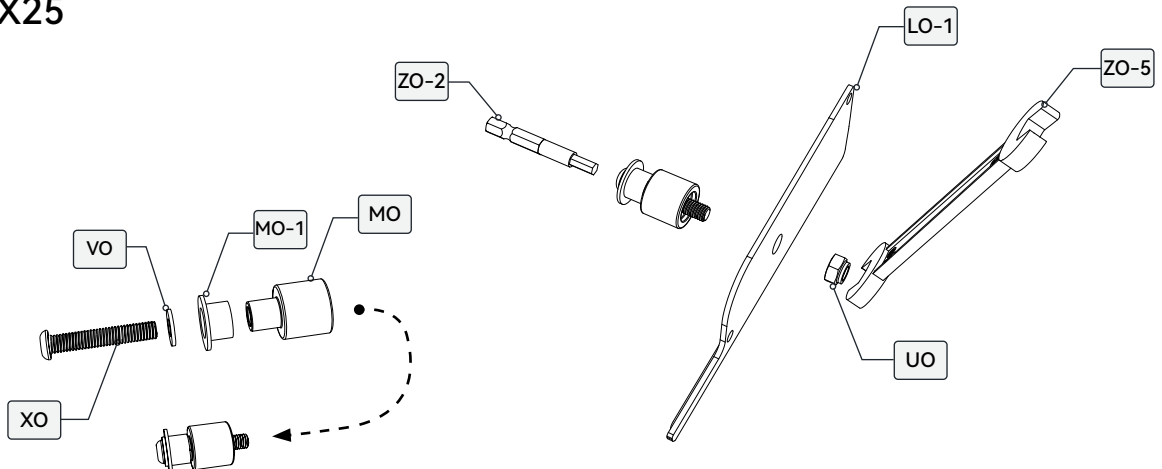

## X25



Installieren Sie die Lamellenabdeckung an beiden Enden der montierten Lamellen und an der Spindellamelle.

GO		25	WO		4x16		PH2	100	ZO-6		PH2
----	---	----	----	---	------	---	-----	-----	------	---	-----

## X1

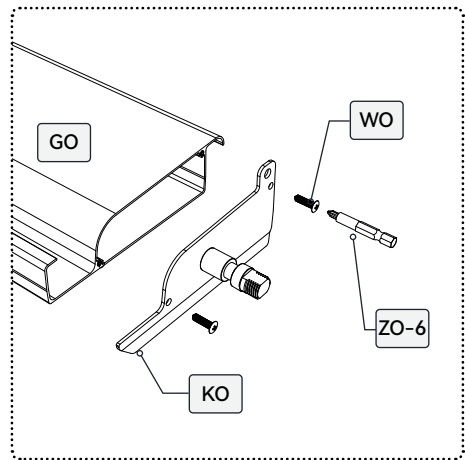
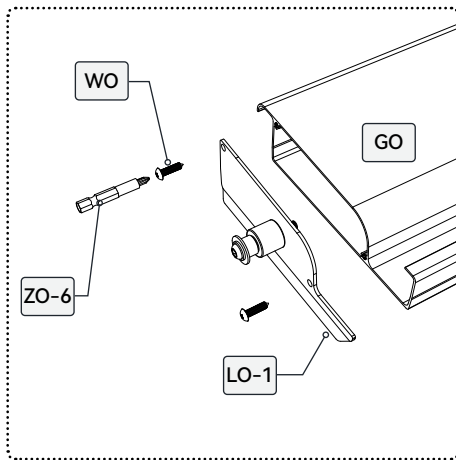

## X24

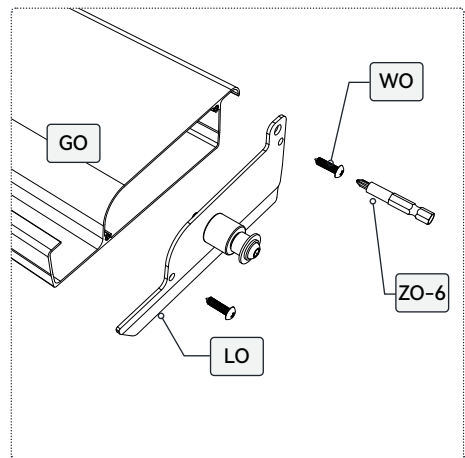
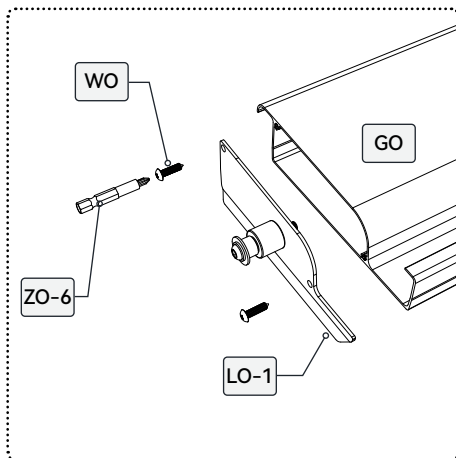
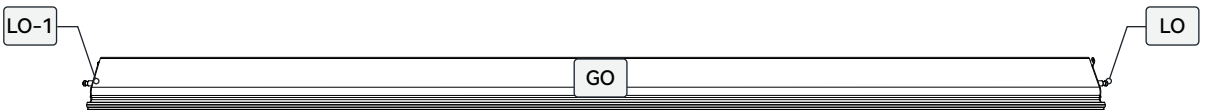

Zuerst das Eingangsende des Controllers mit einem Verlängerungskabel verbinden. Anschließend das Verlängerungskabel durch den Pfosten führen und durch die Entwässerungsöffnung herausleiten, um eine Beeinträchtigung der späteren Installation der Bodenplatte zu vermeiden.

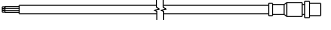

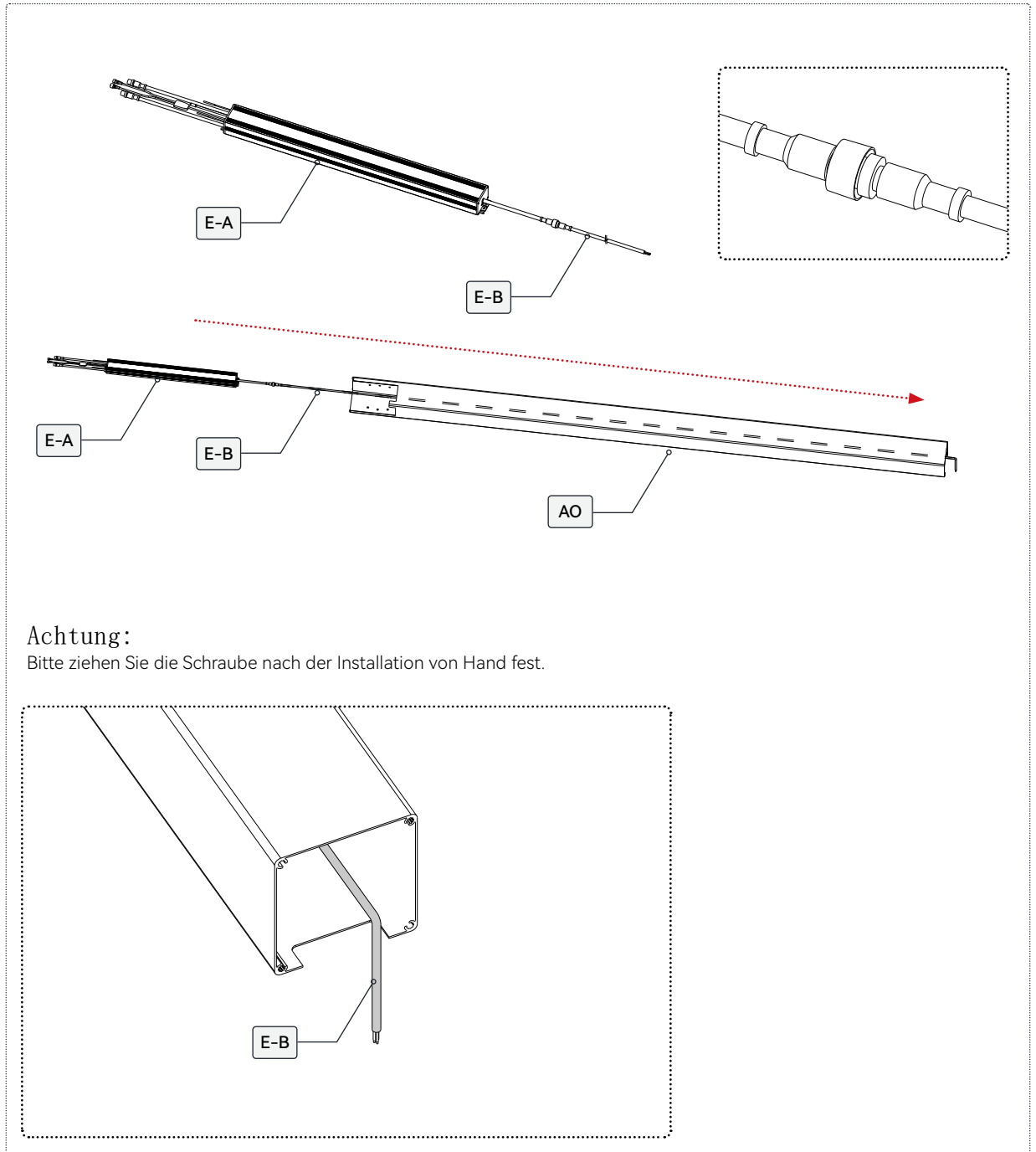





E-A		1
E-B		1

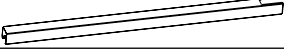

### Achtung:

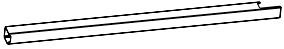
Bitte ziehen Sie die Schraube nach der Installation von Hand fest.

- Installieren Sie zuerst die Pfostenabdeckung.
- Stellen Sie sicher, dass sich der Auslass der Abdeckung und des Pfostens auf derselben Seite befinden.

A0		2	IO		4	XO-1		16	ZO-1	
AO-2		2	JO		4	WO-3		16	ZO-2	

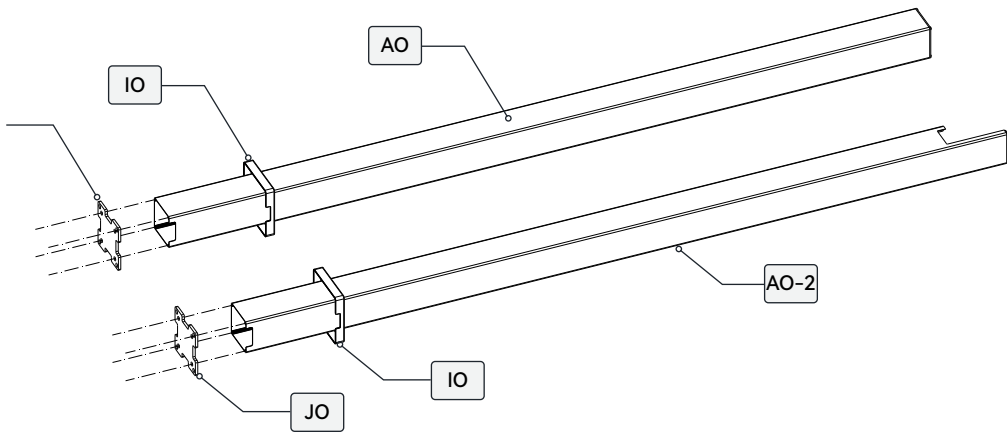

### Achtung:

Bitte ziehen Sie die Schraube nach der Installation von Hand fest.

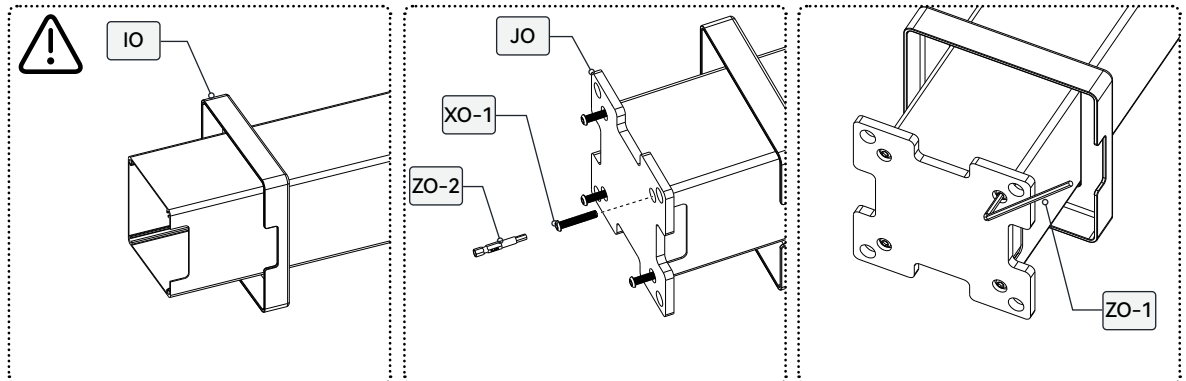

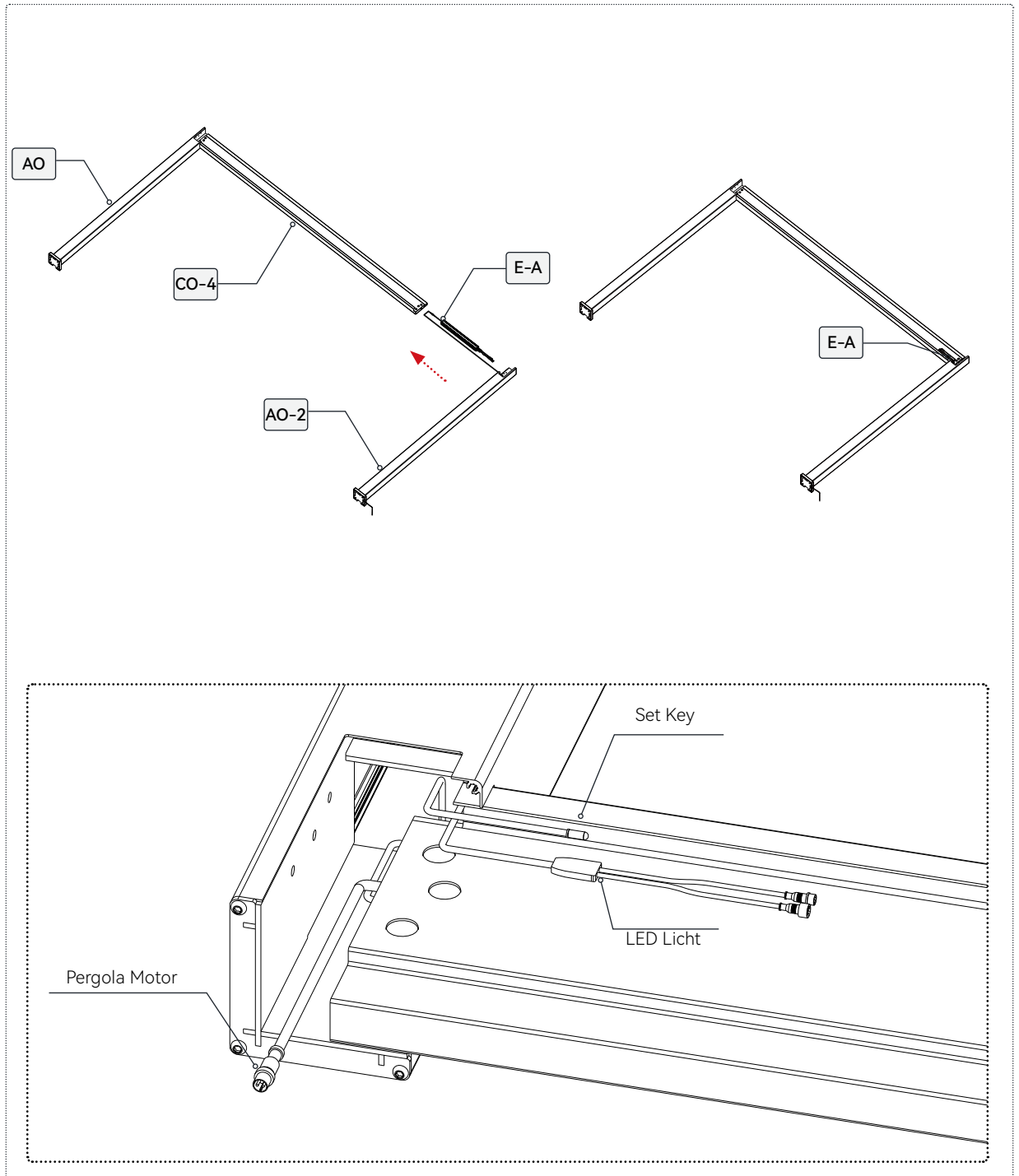

Führen Sie die entsprechenden Ausgangskabel des Controllers heraus, um die spätere Installation zu erleichtern. Achten Sie darauf, den Controller E-A richtig zu positionieren – mindestens 20 cm tief vom Balkenende.

CO-4		1
------	---	---



Installieren Sie die Schrauben für die Seitenbalken.

CO-3		1	Q0			12
------	---	---	----	---	---	----

ZO-1		4mm
ZO-2		4mm

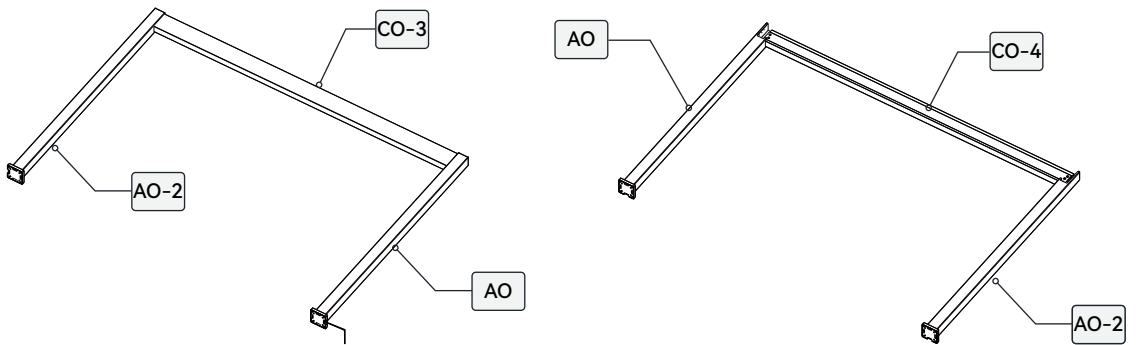

### Achtung:

Bitte ziehen Sie die Schraube nach der Installation von Hand fest.

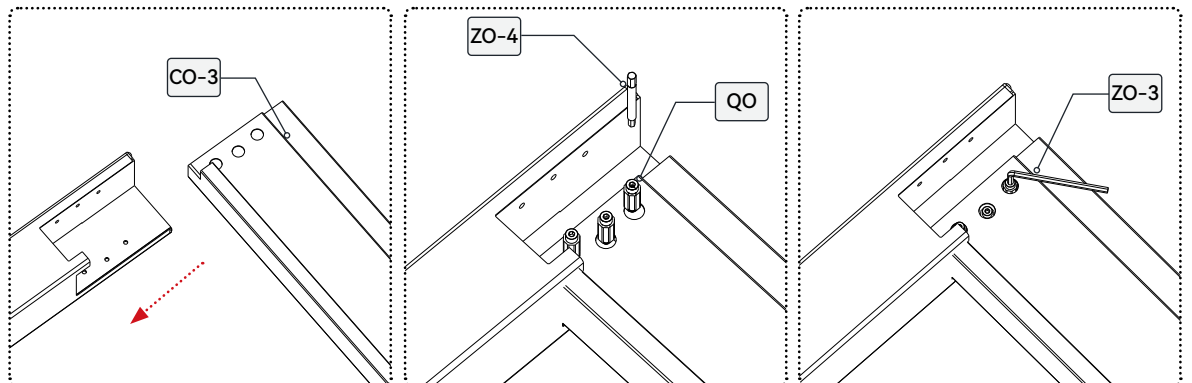



Zuerst die Sekundärträger positionieren, gefolgt von den Primärträgern, wobei das Motorkabel am Primärträger zu beachten ist. Anschließend das Motorkabel vom Steuergerät mit dem Motor verbinden.

B3		1	Q0			12	ZO-1	
BO-4		1					ZO-2	

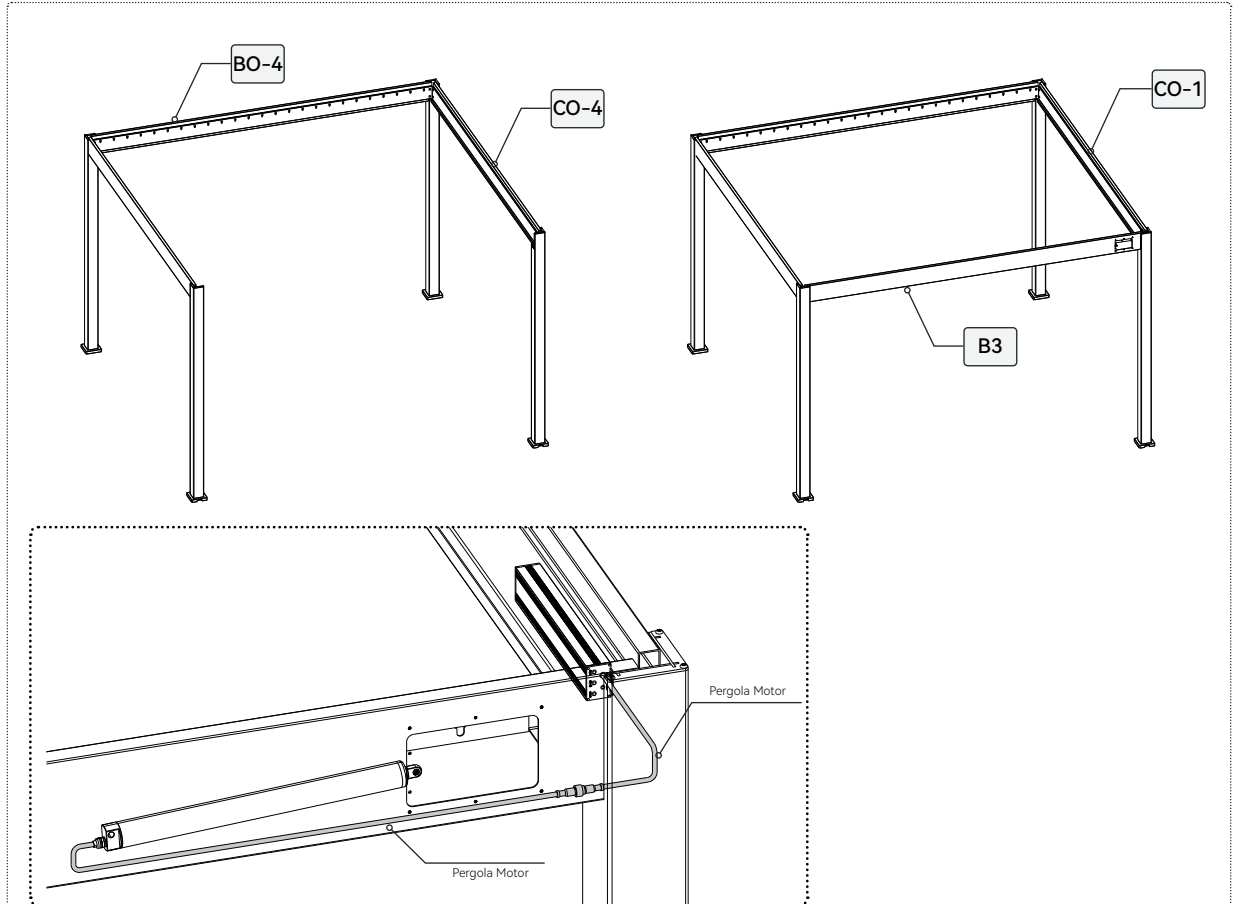

**Achtung:**

Bitte ziehen Sie die Schraube nach der Installation von Hand fest.

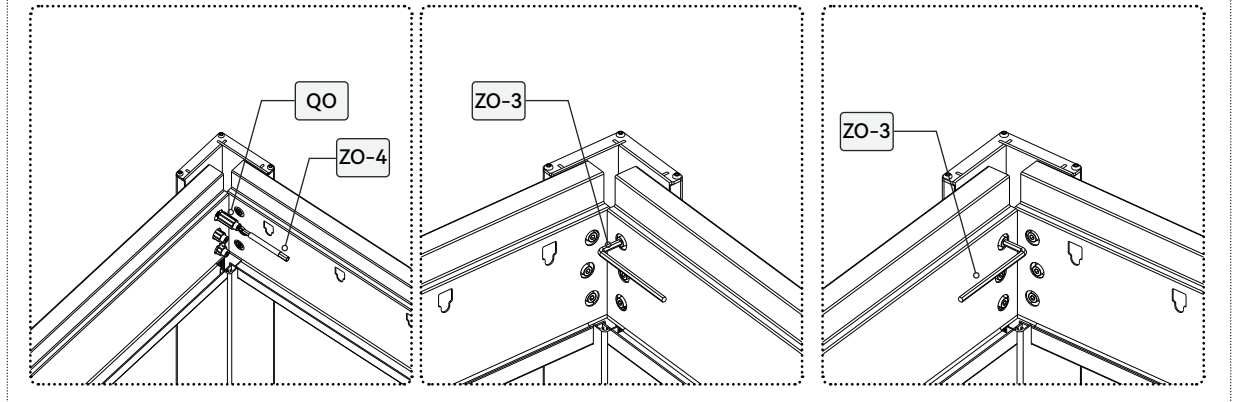

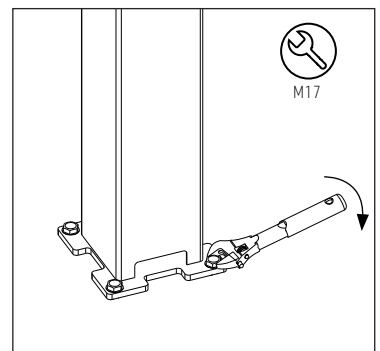
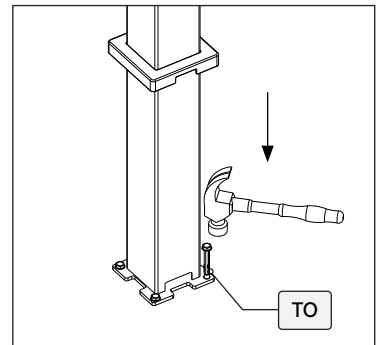
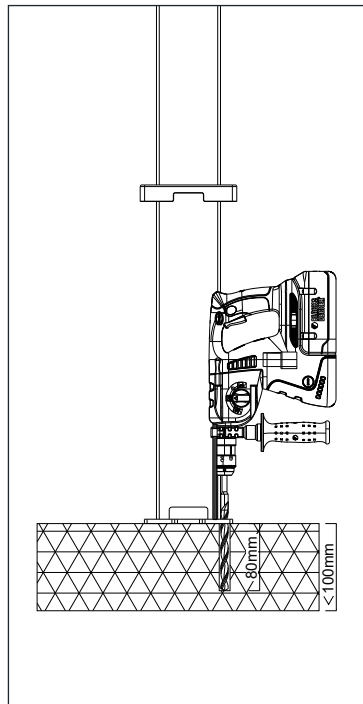
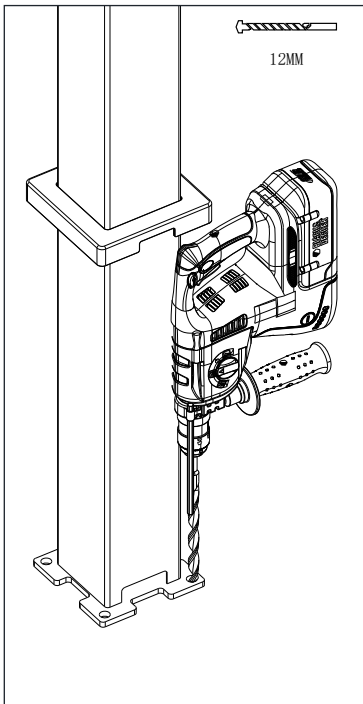
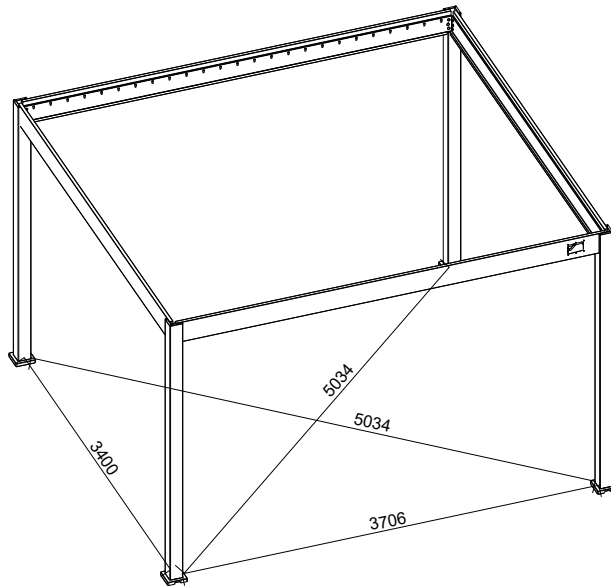

1. Überprüfen Sie die Abmessungen, wie im Diagramm dargestellt.
2. Prüfen Sie mit einer Wasserwaage ob alle Traversen eben stehen, sowie die Pfosten im 90° Winkel zum Boden.
3. Überprüfen Sie die senkrechte Ausrichtung der Pfosten.
4. Verschieben Sie den unteren Rand der Spalten entsprechend den Abmessungen im Diagramm
5. Verwenden Sie einen 12-mm-Schlagbohrer, um die Löcher zu führen, montieren Sie dann die Dehnschrauben und ziehen Sie sie mit einem M17-Schlüssel fest.

T0	 10x80	16
----	---	----

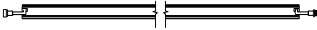

Platzieren Sie den externen Lichtstreifen, verbinden Sie ihn mit dem Controller und verknüpfen Sie sie in Reihe miteinander.

LED1		2
LED2		2

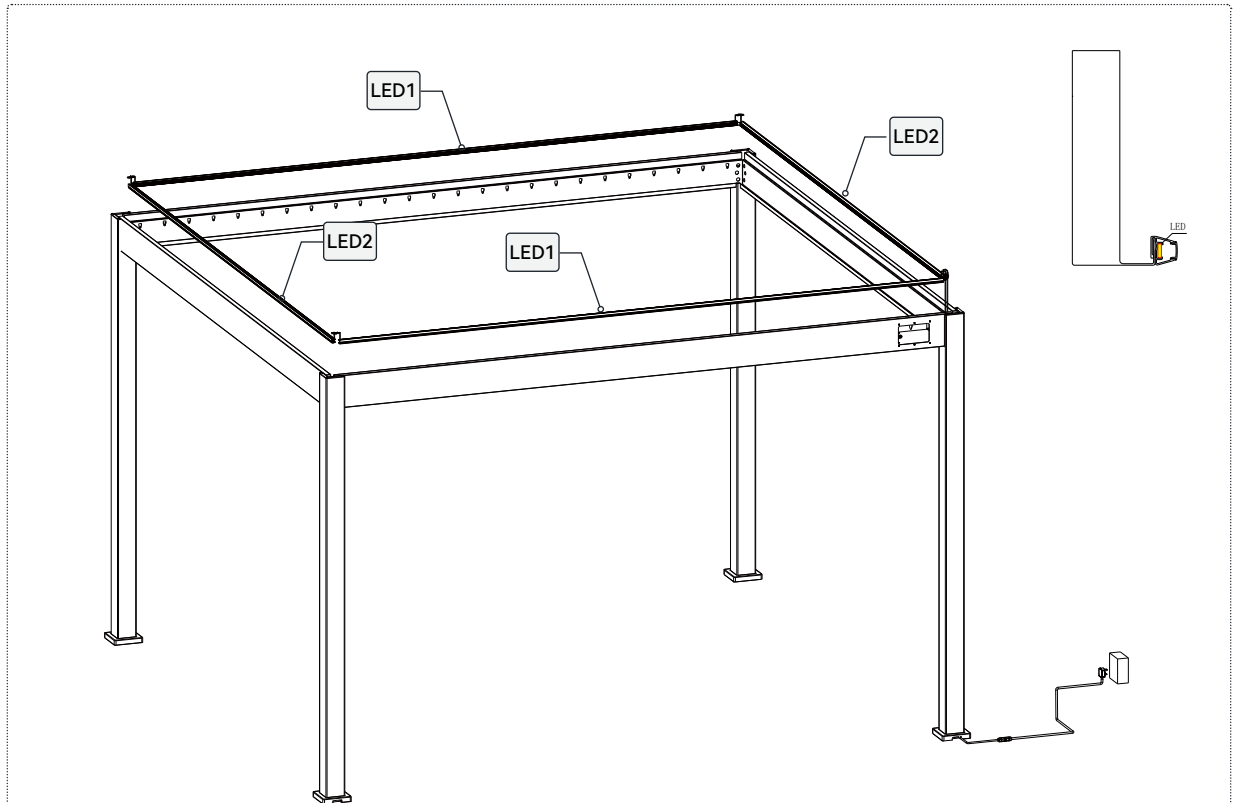

### Achtung:

Verbinden Sie die LED-Streifen miteinander und schließen Sie ein Segment an das LED-Terminal des Controllers an. Nach Abschluss der Verkabelung führen Sie die Kabel sicher in die Entwässerungsöffnung.

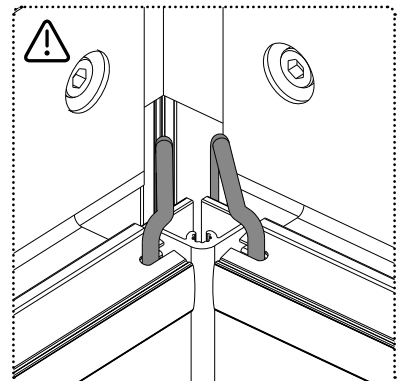
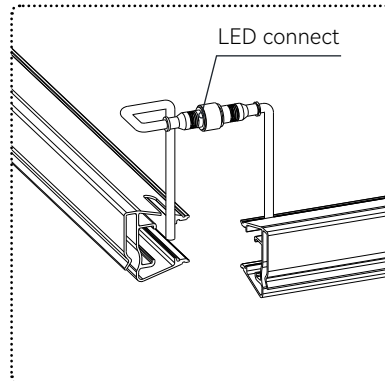
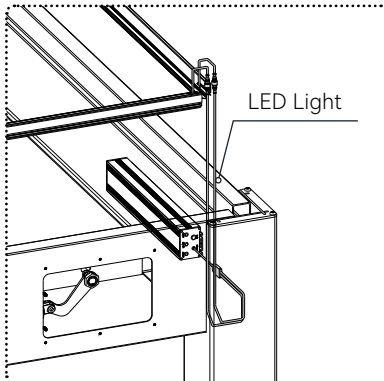

Installieren Sie die Hauptwellenlamellen und befestigen Sie sie mit Schrauben. Stellen Sie sicher, dass die Lamellen waagrecht ausgerichtet sind.

UO-3	 M14	1
------	---	---

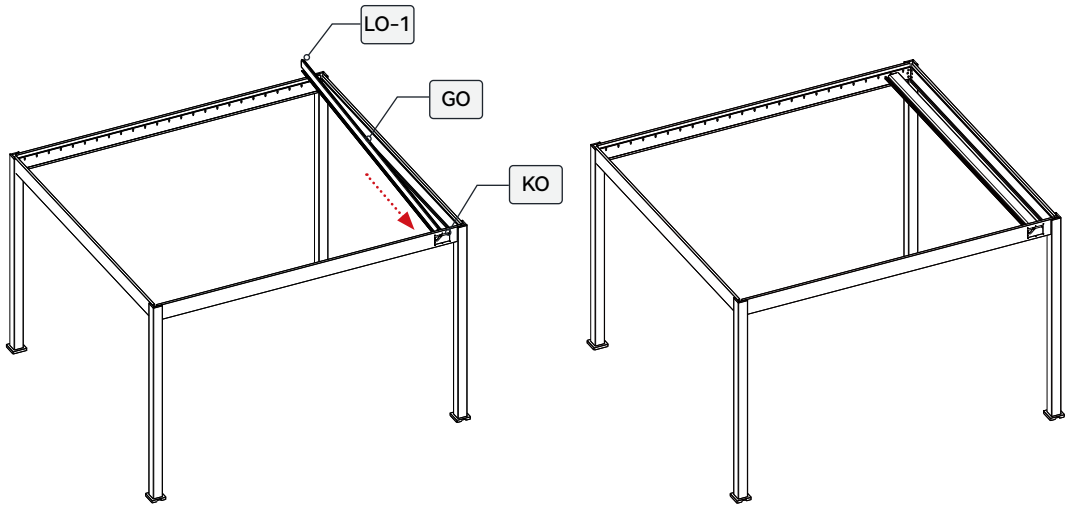

### Achtung:

Ziehen Sie die Schrauben mit einem Schraubenschlüssel fest.

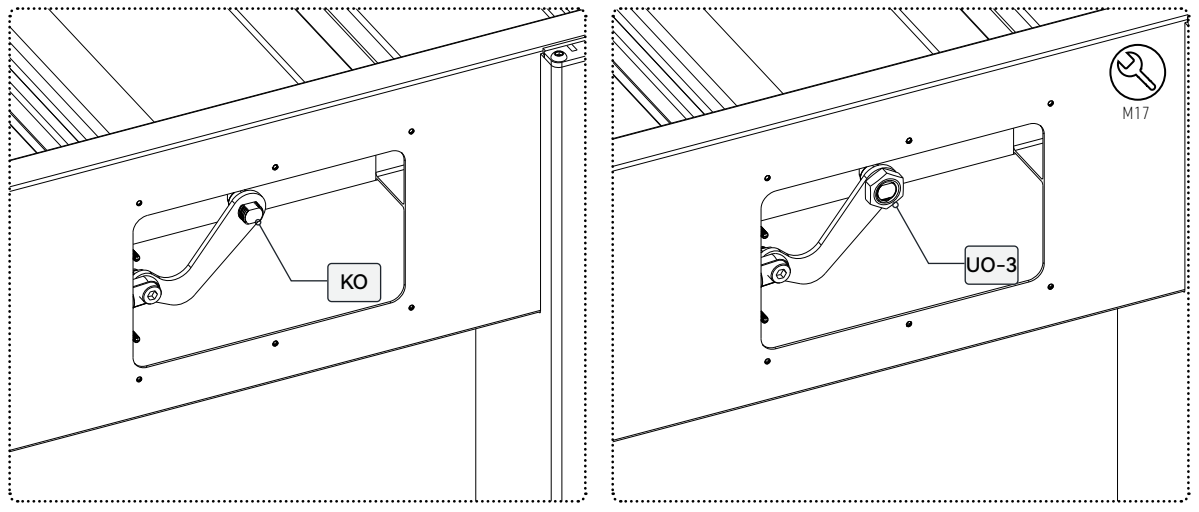

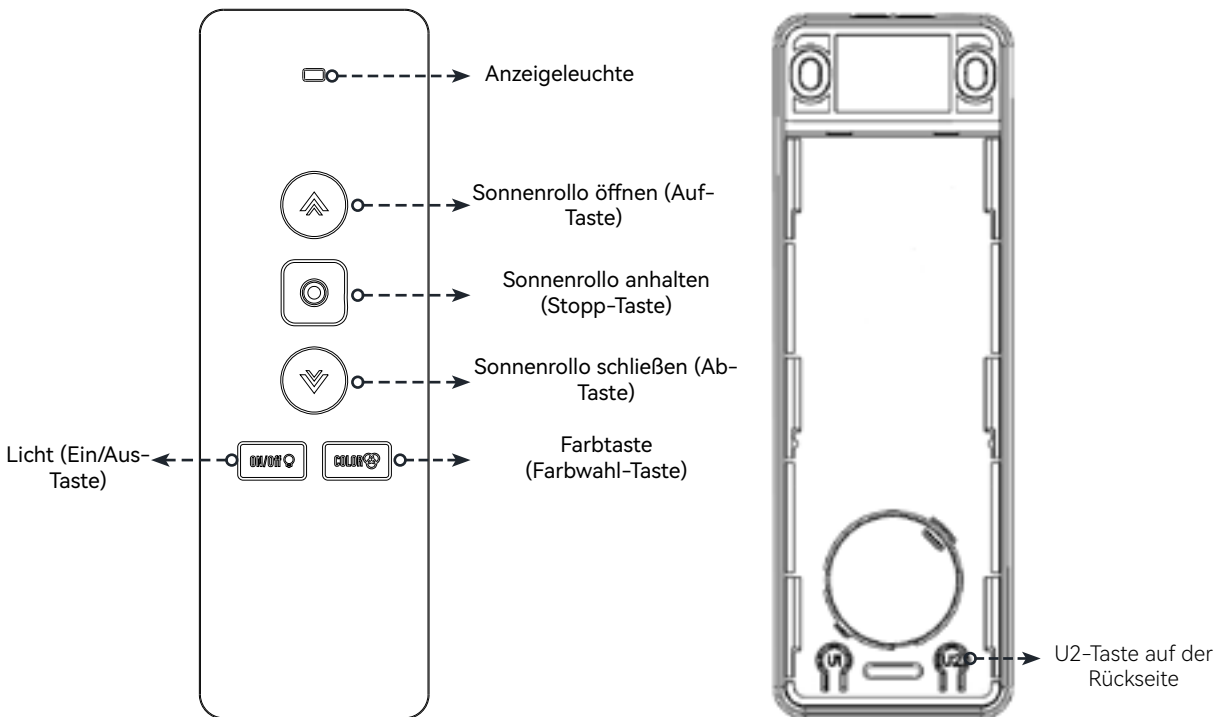

## RGB-Beleuchtungsfunktion

### Funktion der Licht-Einschalttaste:

Kurzer Druck: Schaltet das Licht ein/aus im Wechsel.

Langer Druck (2 Sekunden): Stufenweise Helligkeitsregelung, mit allmählichem Dimmen und Aufhellen.

### Funktion der Farbtaste:

Kurzer Druck: Wechselt durch 8 Farbmodi: Rot, Grün, Blau, Gelb, Cyan, Lila, Weiß und automatischer Farbwechsel.

Langer Druck (2 Sekunden): Stufenweise Farbwechsel und Farbanpassung.

Das Produkt unterstützt auch die TUYA-Funktion. Es kann durch das Herunterladen der TUYA-App gesteuert werden. Der Benutzer sollte diese Funktion nur nutzen, wenn das WLAN-Signal ausreichend ist.



### Netzwerk zurücksetzen:

Halten Sie die Taste "SET KEY" am Controller 7 Sekunden lang gedrückt.

Die Anzeigeleuchte erlischt für 1 Sekunde, was anzeigt, dass das Netzwerk erfolgreich zurückgesetzt wurde.

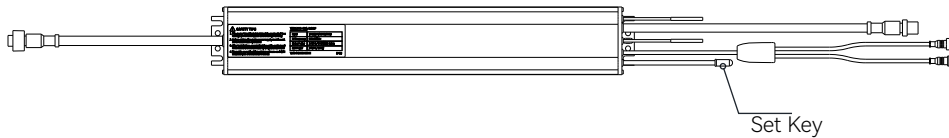

### Anleitung zur Fernbedienungskopplung

Unten sind zwei Methoden zur Kopplung der Fernbedienung aufgeführt – übersichtlich und leicht verständlich:

#### Kopplungsmethode 1:

##### Kopplungsmodus aktivieren:

Halten Sie die "SET KEY"-Taste am Controller 2 Sekunden lang gedrückt. Die Anzeigeleuchte beginnt langsam zu blinken, was darauf hinweist, dass der Kopplungsmodus aktiviert wurde.

##### Kopplung abschließen:

Halten Sie die "Stopp-Taste" auf der Fernbedienung 2 Sekunden lang gedrückt. Die Anzeigeleuchte erlischt für 1 Sekunde, was anzeigt, dass die Fernbedienung erfolgreich gekoppelt wurde.

#### Kopplungsmethode 2:

##### Kopplungsmodus aktivieren:

Halten Sie die "U2-Taste" auf der Rückseite einer bereits gekoppelten Fernbedienung 2 Sekunden lang gedrückt. Die Anzeigeleuchte beginnt langsam zu blinken, was darauf hinweist, dass der Kopplungsmodus aktiviert wurde.

##### Neue Fernbedienung hinzufügen:

Halten Sie die "Stopp-Taste" auf der neuen Fernbedienung, die gekoppelt werden soll, 2 Sekunden lang gedrückt. Die Anzeigeleuchte erlischt für 1 Sekunde, was anzeigt, dass die neue Fernbedienung erfolgreich hinzugefügt wurde.

#### Hinweise:

Stellen Sie sicher, dass sich die Fernbedienung und der Controller innerhalb der effektiven Reichweite befinden.

Falls die Anzeigeleuchte nicht wie erwartet reagiert, wiederholen Sie den Vorgang oder überprüfen Sie die Funktion des Geräts.

Unterschiedliche Marken oder Modelle können abweichende Vorgehensweisen haben. Bitte beachten Sie die Bedienungsanleitung des jeweiligen Geräts.

Versorgen Sie die Pergola mit Strom und verwenden Sie die Fernbedienung, um die Lamellen in eine 90-Grad-Position zu drehen. Dadurch wird die anschließende Installation weiterer Lamellen erleichtert.

E-CR		1
------	---	---

Setzen Sie die Batterie (separat erhältlich) in die Fernbedienung (E-CR) ein. Hinweis: Wir empfehlen das Batteriemodell CR2450.

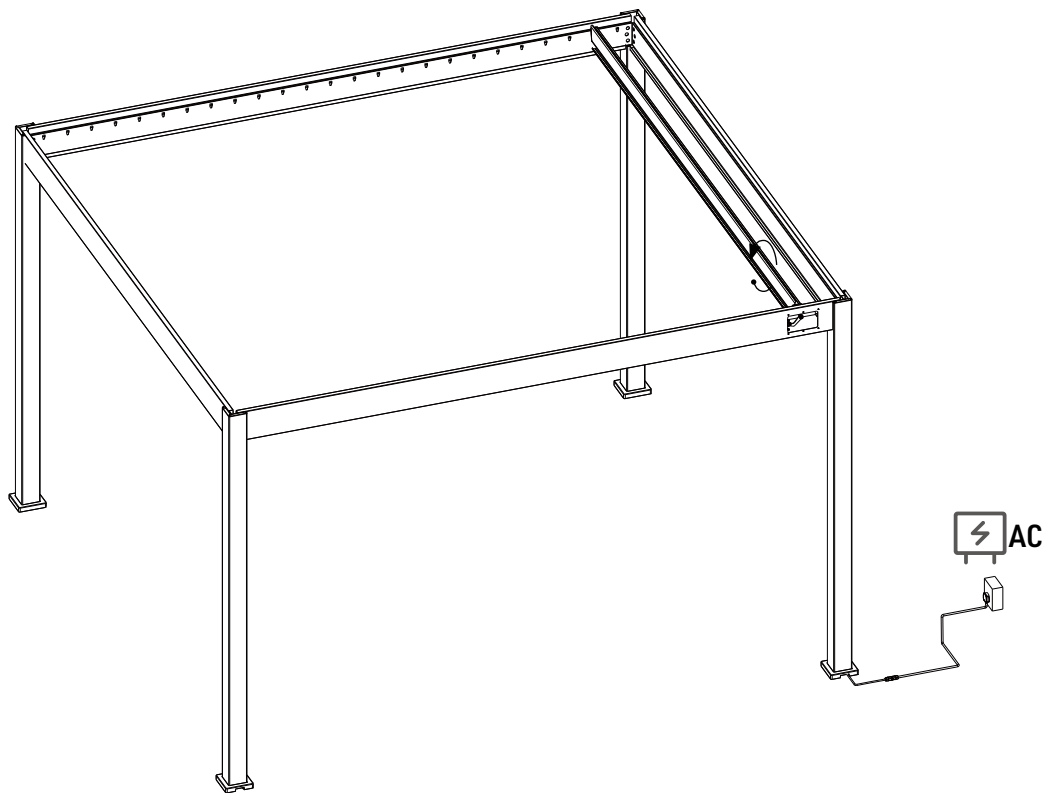

90 Grad drehen



Installieren Sie die Lamellen der Pergola und befestigen Sie die Endkappen auf beiden Seiten.



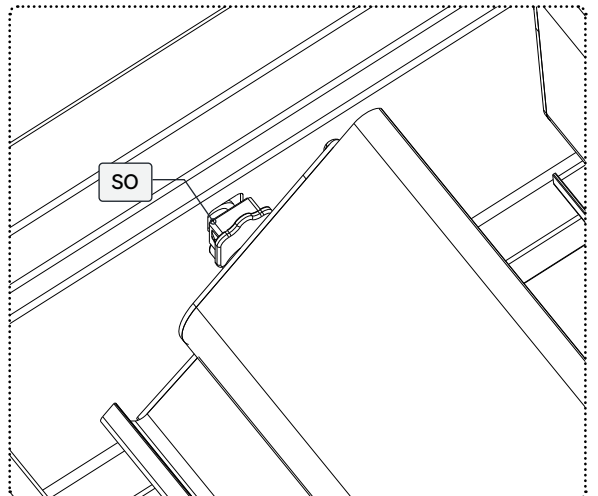
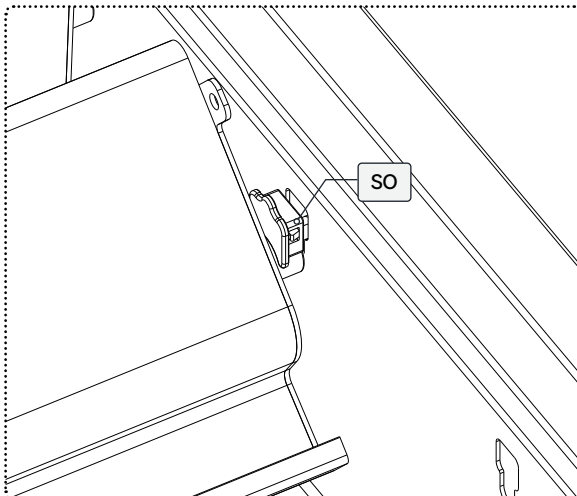
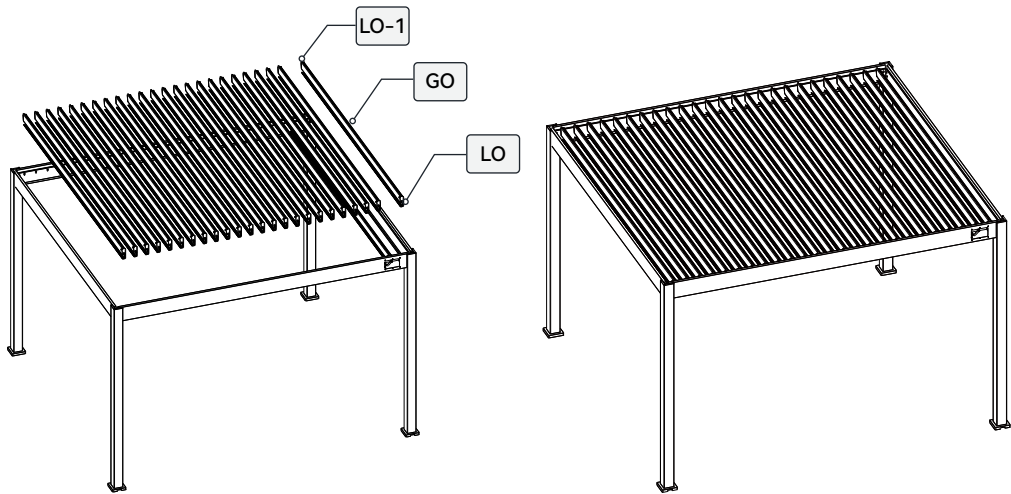





SO		50
----	---	----





Vervollständigen Sie die Verbindung der Verbindungsstange.

1. Die Schraube „XO-2“ muss nach der Montage der Kontermutter (aus Metall) „UO“ noch 2 mm Gewindeüberstand haben.
2. Die Schraube „XO-2“ sollte nach der vollständigen Montage der Antriebsschiene „FO“ noch beweglich sein.
3. Testen Sie die Bewegungsfreiheit mit dem Inbus „ZO-1“.

FO		1	XO-2			25	UO		25	ZO-1		4mm
							UO-1		25	ZO-2		4mm
							VO		75	ZO-5		10mm

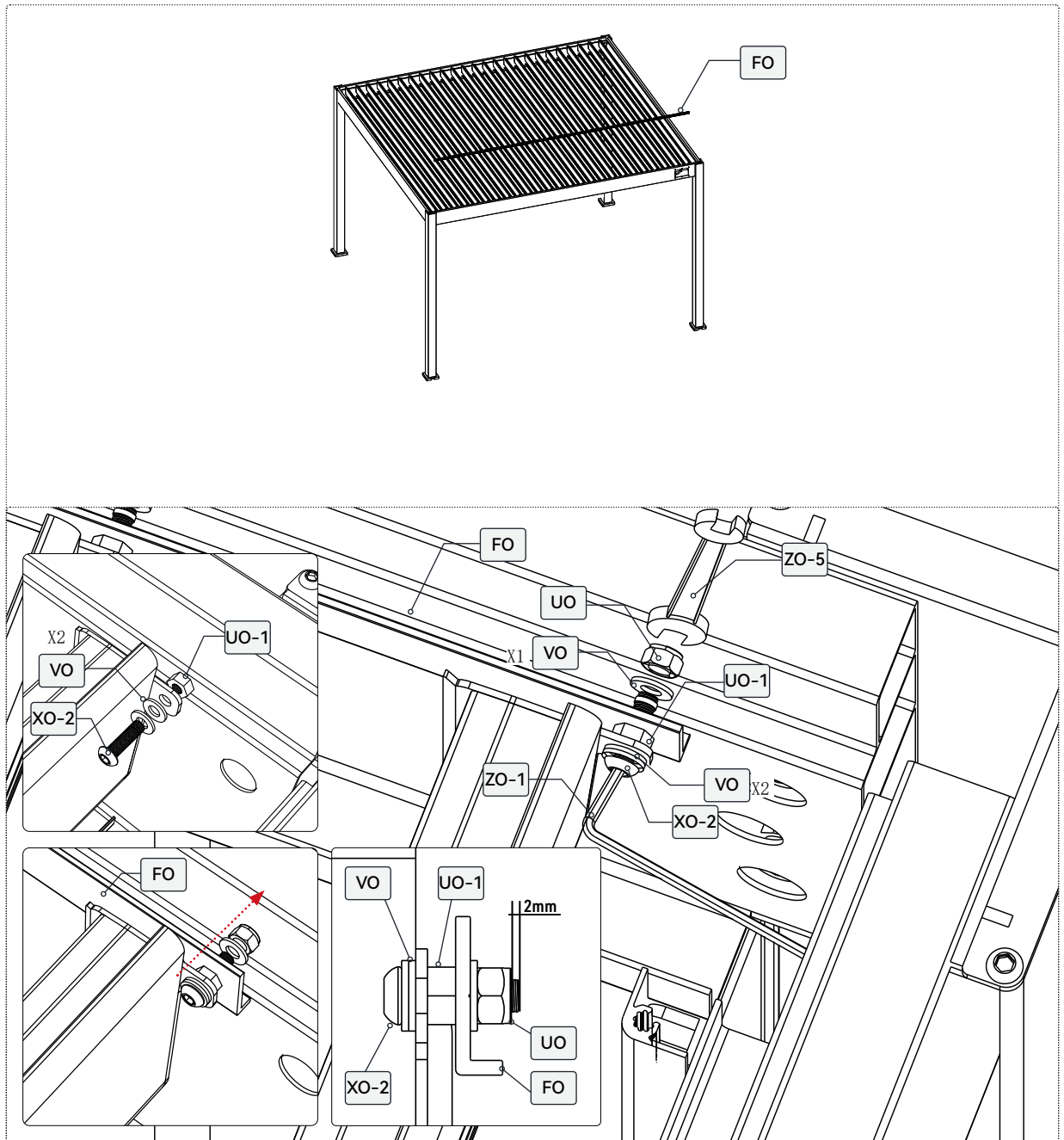

1. Vor Abschluss der Installation wird ein Funktionstest der Lamellen empfohlen. Dies hilft, eventuelle Schäden zu erkennen, die mit bloßem Auge nicht sichtbar sind.
2. Schließen Sie die Lamellen und stellen Sie sicher, dass sie reibungslos ineinandergleiten. Es sollte keine Berührung, Fehlansichtung oder Schleifgeräusche zwischen den Lamellen geben.
3. Installieren Sie die Abdeckplatte und die Kappe.

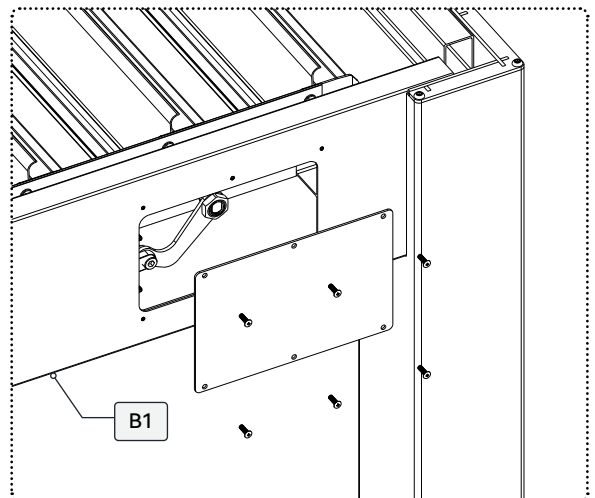
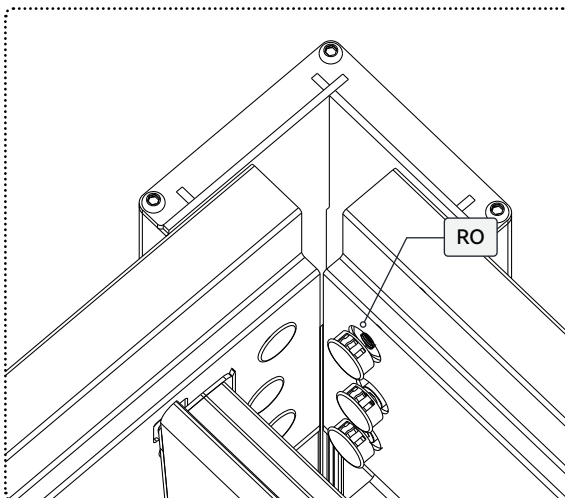
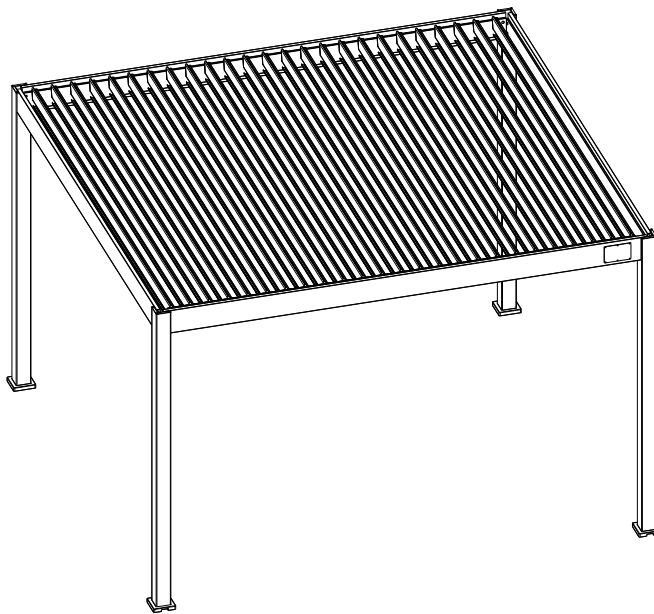





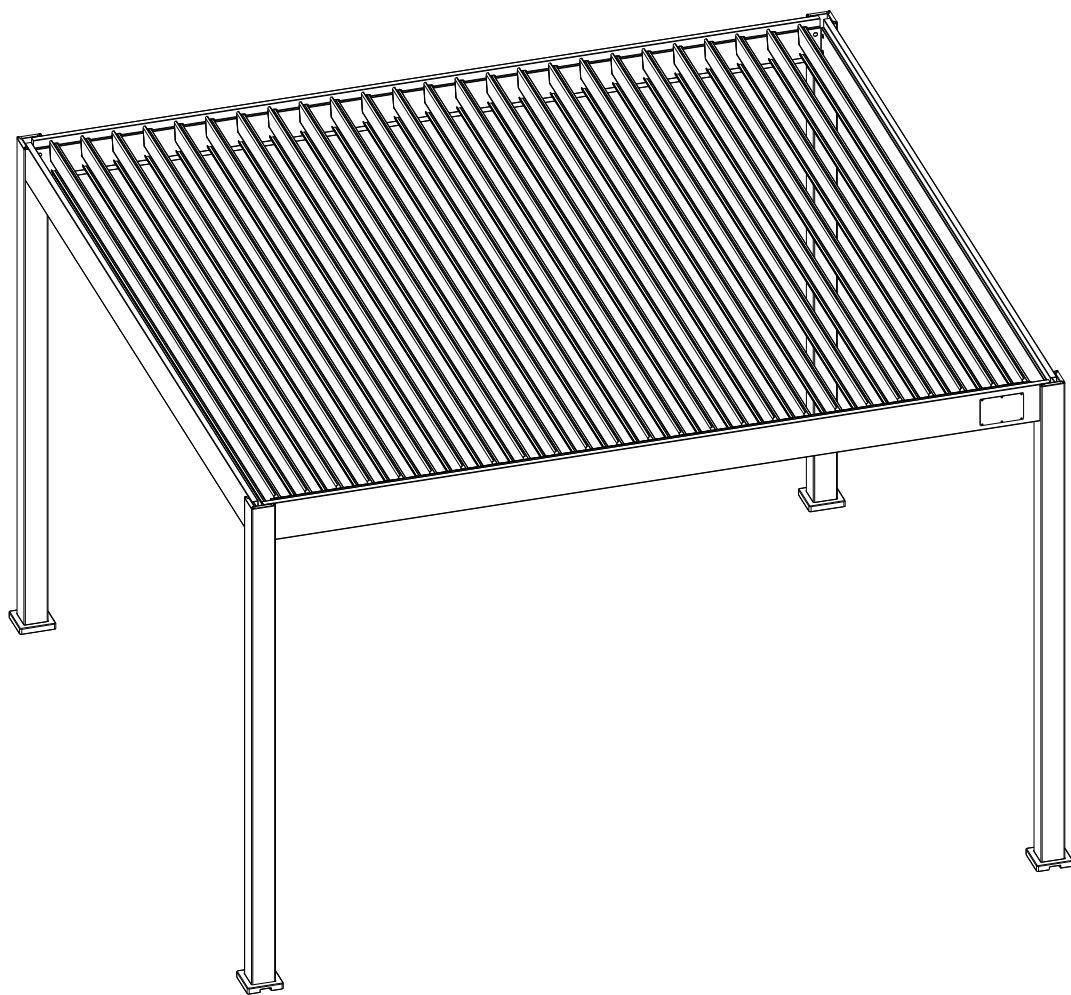

# Electric Pergola Aluminium

INSTRUCTION MANUAL

**3.6×4**  
ELE+LED



# We appreciate your purchase of our Pergola.

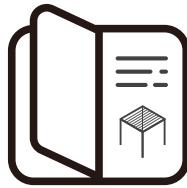

## Instruction Manual

This guide will give you step-by-step instructions on how to assemble and care for your pergola, ensuring it lasts for years of enjoyment and reliable use.

Be sure to follow all steps carefully, as in correct installation may result in serious injury.

---

### IMPORTANT:

Warning: Safety Instructions

For the safety of individuals, it is crucial to follow these instructions. Please retain them for future reference

Children and individuals with disabilities or limited experience may use the appliance if they are properly supervised or trained and understand the potential risks.

Children should not be allowed to play with the appliance. Cleaning and maintenance tasks should only be performed by children under supervision.

This pergola is designed for outdoor residential use, providing protection from direct sunlight, glare, and heat.

Any use or modification not outlined in this manual is considered improper and could pose significant risks to both users and property. Such actions will void the product warranty.

# BEFORE THE INSTALLATION

## PREPARE ALL THE NECESSARY TOOLS

To assemble your pergola properly and safely, make sure you have the following tools and accessories on hand, as these are not included.

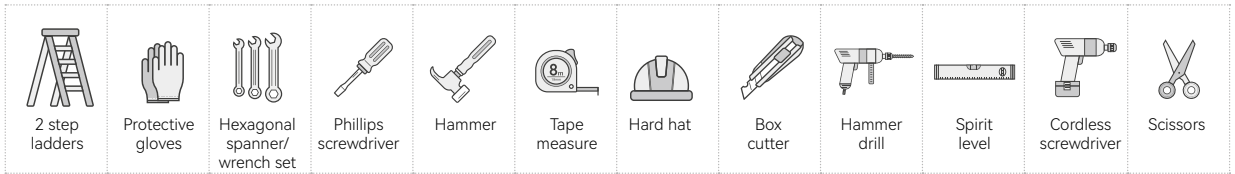

## CHECK FOR MISSING PARTS:

Before starting the installation, verify that you have all the necessary parts to assemble your e-Motion. Double-check that the quantity of parts matches the model you purchased.

If any parts are missing, please reach out to customer service before proceeding with the installation.

## PREPARE THE PARTS FOR EACH STEP:

In the Installation section of the manual, each step specifies the parts and quantities needed. We recommend gathering the necessary parts ahead of time for each step. This will help save you time and make the assembly process smoother. To avoid damaging the painted surfaces, place the parts on cardboard or another soft surface if possible.

## CHOOSE AN APPROPRIATE LOCATION:

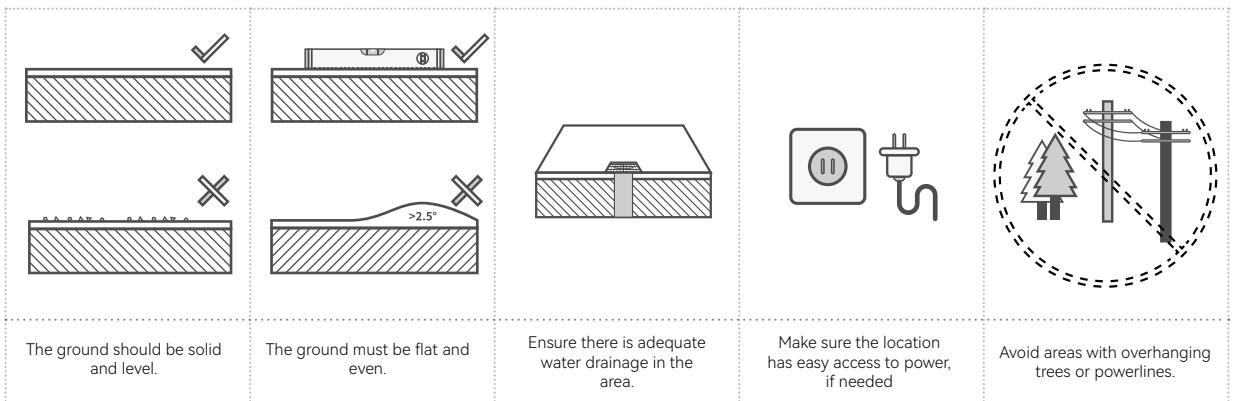

## WARNING:

Many terraces or patios are built with a slight slope to direct rainwater away from the house or other structures. For proper pergola installation, a completely level surface is required. Small pebbles or uneven ground may prevent the pergola from being securely anchored.

If the pergola is installed on an uneven surface, it may affect the performance of accessory components and could void the product warranty. You may also need to adjust the height of the pillars for proper installation.

## PREPARE THE FOUNDATION:

To get your foundation ready, make sure to:

Check for underground pipes and cables (call local relative authorities before digging).















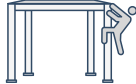

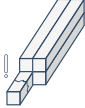
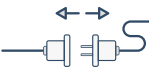
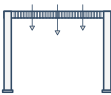

Verify with local authorities if any building permits are necessary.

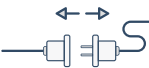

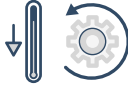

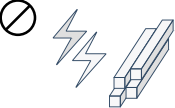

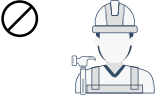
If you're opting for a concrete base, consult with a reputable contractor.

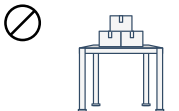
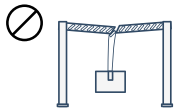

# IMPORTANT SAFETY SUGGESTIONS

To ensure the safety of everyone involved in the installation and use of the pergola, it is essential to follow the safety guidelines listed below.

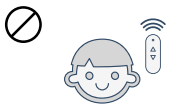
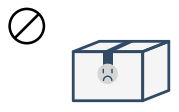
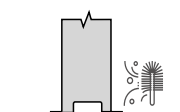
	<p>The pergola must be placed and secured on a flat, level surface.</p>		<p>Always wear suitable work shoes, gloves, and eye protection during assembly.</p>
	<p>When using power tools or a ladder, always adhere to the manufacturer's safety instructions.</p>		<p>Always wear protective gear to minimize the risk of injury in case of a fall.</p>
	<p>Ensure the pergola meets local building regulations and codes.</p>		<p>Do not step on the louvers.</p>
	<p>Use only ladders and scaffolding that can support the required weight.</p>		<p>Visually inspect the pergola for damage prior to each use. If damage is detected, stop using it immediately and reach out to authorized personnel to fix it.</p>
	<p>Remove any excess cords and disconnect any non-essential equipment before installing the drive.</p>		<p>To avoid damage, set the louvers in the vertical position during snow or windy conditions.</p>
	<p>Unprotected moving parts that pose a hazard should be installed more than 2.5 meters above the floor or any surface that could allow access to them.</p>		<p>Always use replacement parts that are approved by the manufacturer.</p>
	<p>To avoid damage to the pergola, ensure that foliage or foreign objects on the louvers and in the guide rails are removed frequently.</p>		<p>Only certified personnel are authorized to carry out electrical installation, following the relevant regulations</p>
	<p>Disconnect all electrical connections from the mains prior to installation.</p>		<p>Operate the pergola remotely only when you can see the moving parts clearly.</p>
	<p>Only a licensed electrical contractor should install the power sources for electric pergolas.</p>		<p>If the motor undergoes repeated open-close cycles, it may enter overheat protection mode and will return to normal once it cools down.</p>
	<p>Keep children and pets away from the assembly area until the installation is fully completed.</p>		<p>Dispose of all plastic bags responsibly and keep them out of reach of children.</p>
	<p>Keep a safe distance from power lines, especially when handling metal parts.</p>		<p>Avoid assembling the pergola in windy or wet conditions.</p>
	<p>In the event of a damaged supply cord, only the manufacturer, a service agent, or similarly qualified personnel should replace it</p>		<p>Do not store hot items, such as recently used grills or blowtorches, under or near the pergola.</p>

	To prevent damage to the louvers' drive, do not operate the roof mechanism in the presence of frost or ice.		Keep clothing and body parts clear of the pergola to avoid them becoming caught in the moving parts.
	Keep items off the louvers.		It is not allowed to hang objects on the pergola, as it may result in serious damage.
	Before making any modifications to the design or configuration of the equipment, consult the manufacturer or an authorized representative.		Keep children away from the fixed controls and ensure remote controls are out of their reach.
	The warranty will be voided, and the operating mechanism may be damaged if non-original branded accessories are installed.		Important: Regularly clean the columns' drainage holes with a soft brush to prevent blockages and damage.
	We guarantee the resistance of the pergola for winds up to 80km/h		We guarantee the resistance of the pergola for a maximum snowweight of 50kg/m2

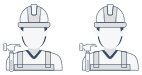

## 2 PERSONNEL REQUIRED

Electric control system are in the cavity of the post.

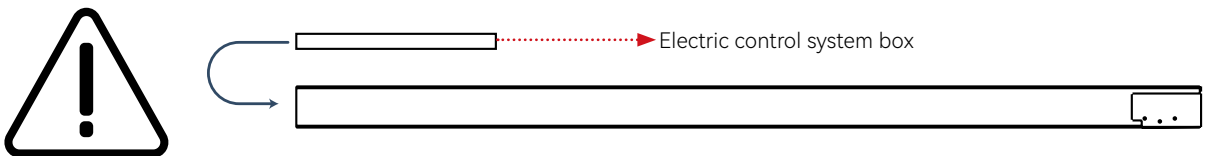

Connecting bar & brush are in the cavity of the beam.



There is a Product Tracking Number in the inner side of the carton (see below diagram). For better and efficient after-sales in the future, when tear down the carton box, please take a photo of the Tracking Number and save the photo.

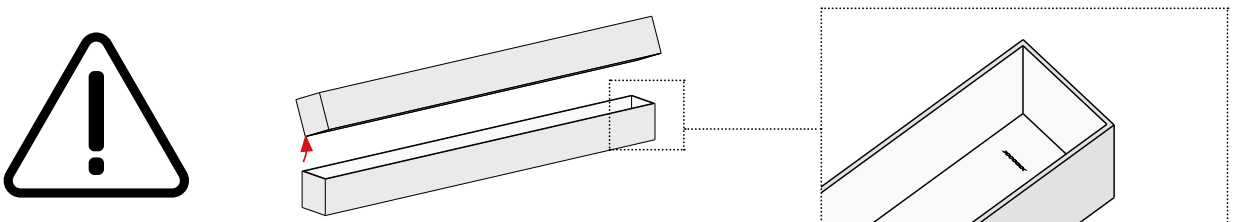

# PERGOLA SIZE

# 3.6X4

Plan Size

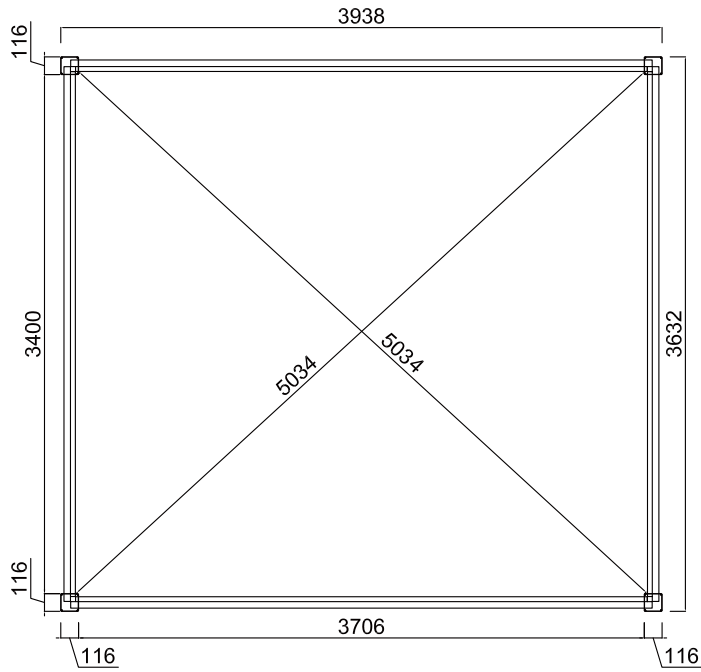

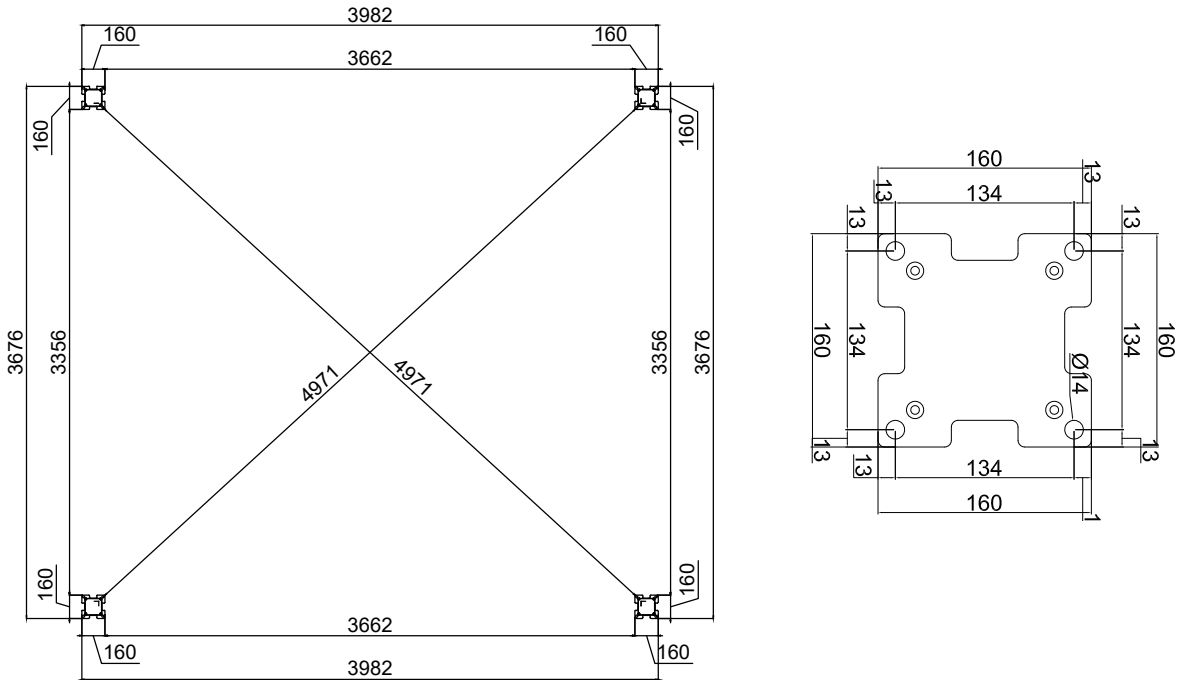

Base Plate Layout Plan







# SPARE PART LIST

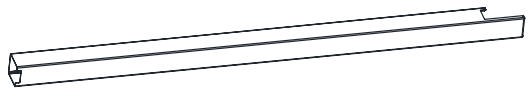



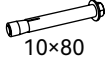

# 3.6X4

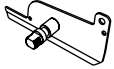
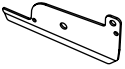

CARTON 1/5

No.	Profile	Diagram	Size	QTY
A0			136X136 L=2550mm	2
A0-2			116X116 L=2550mm	2

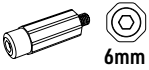
No.	Diagram	QTY
I0		4
J0		4

No.	Diagram	QTY
T0	 10x80	16
X0-1	 6x35      4mm	16







No.	Diagram	QTY
K0		1
L0		24
L0-1		25
M0		49
M0-1		49
Q0	 6mm	24
R0		24
S0		50

No.	Diagram	QTY
U0	 lock nut	74
U0-1	 plastic nut	25
U0-3	 M14	1
V0		124
W0	 4x16      PH2	100
X0	 6x40      4mm	49
X0-2	 6x20      4mm	25

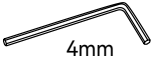
# SPARE PART LIST

# 3.6X4

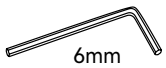
CARTON 1/5



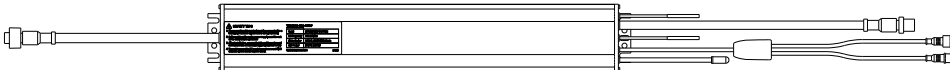
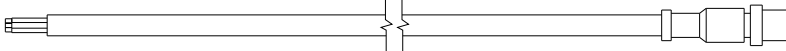
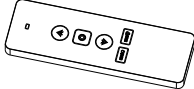
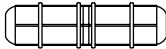







No.	Diagram	QTY	No.	Diagram	QTY
Z0-1	 4mm	1	Z0-4	 6mm	1
Z0-2	 4mm	1	Z0-5	 10mm	1
Z0-3	 6mm	1	Z0-6	 PH2	1



No.	Diagram	QTY
E-A		1
E-B		1
E-CR		1
E-D		1

# SPARE PART LIST

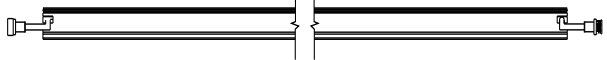

# 3.6X4

## CARTON 2/5

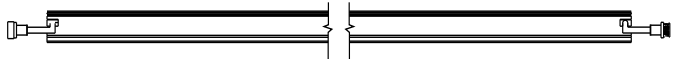

No.	Profile	Diagram	Size	QTY
B3			75X195 L=3809mm	1
B0-4			75X195 L=3809mm	1
C0-3			75X195 L=3503mm	1
C0-4			75X195 L=3503mm	1
F0			27X8 L=3650mm	1

No.	Profile	Diagram	Size	QTY
LED1			69X78 L=3705mm	2
LED2			69X78 L=3399mm	2



## CARTON 3/5

No.	Profile	Diagram	Size	QTY
G0			166X38 L=3464mm	9

## CARTON 4/5

No.	Profile	Diagram	Size	QTY
G0			166X38 L=3464mm	9

## CARTON 5/5

No.	Profile	Diagram	Size	QTY
G0			166X38 L=3464mm	7

---

Before proceeding with the assembly of your louvered pergola, it is necessary to check that all parts listed are supplied and not damaged.

Any missing part must be reported within 10 days of delivery.

Do not discard the packaging without ensuring that the product is functioning properly.

**Attention:**

Please note that the outlet on the skirt should be in the front position for the front side, while for the rear side, the outlet is a mirror image of the front face.

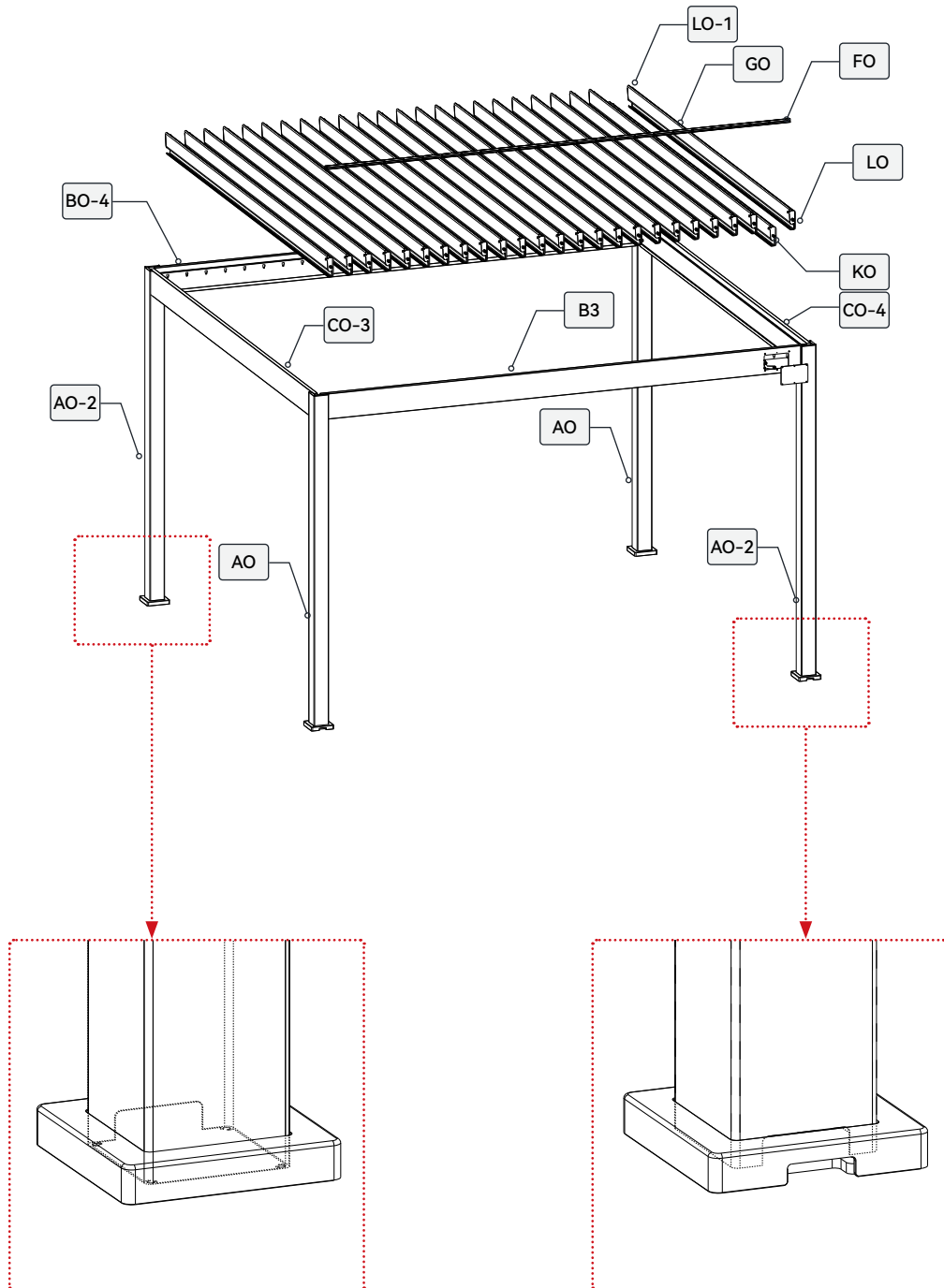



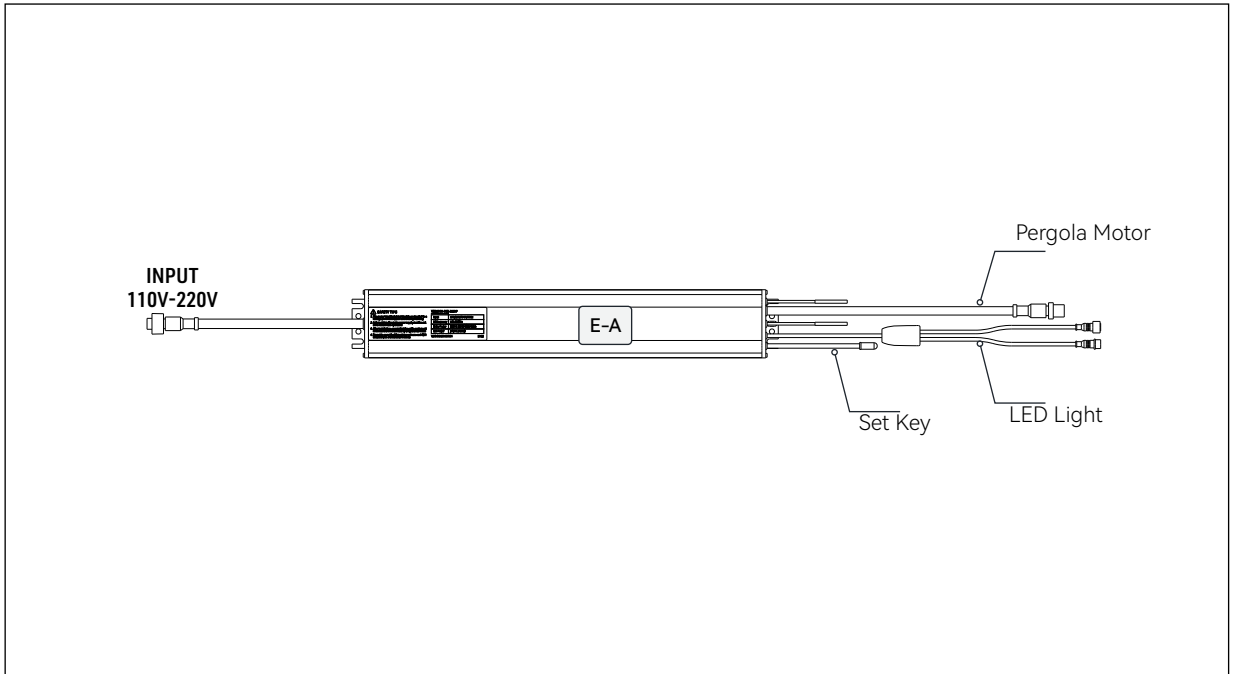

Cable Diagram

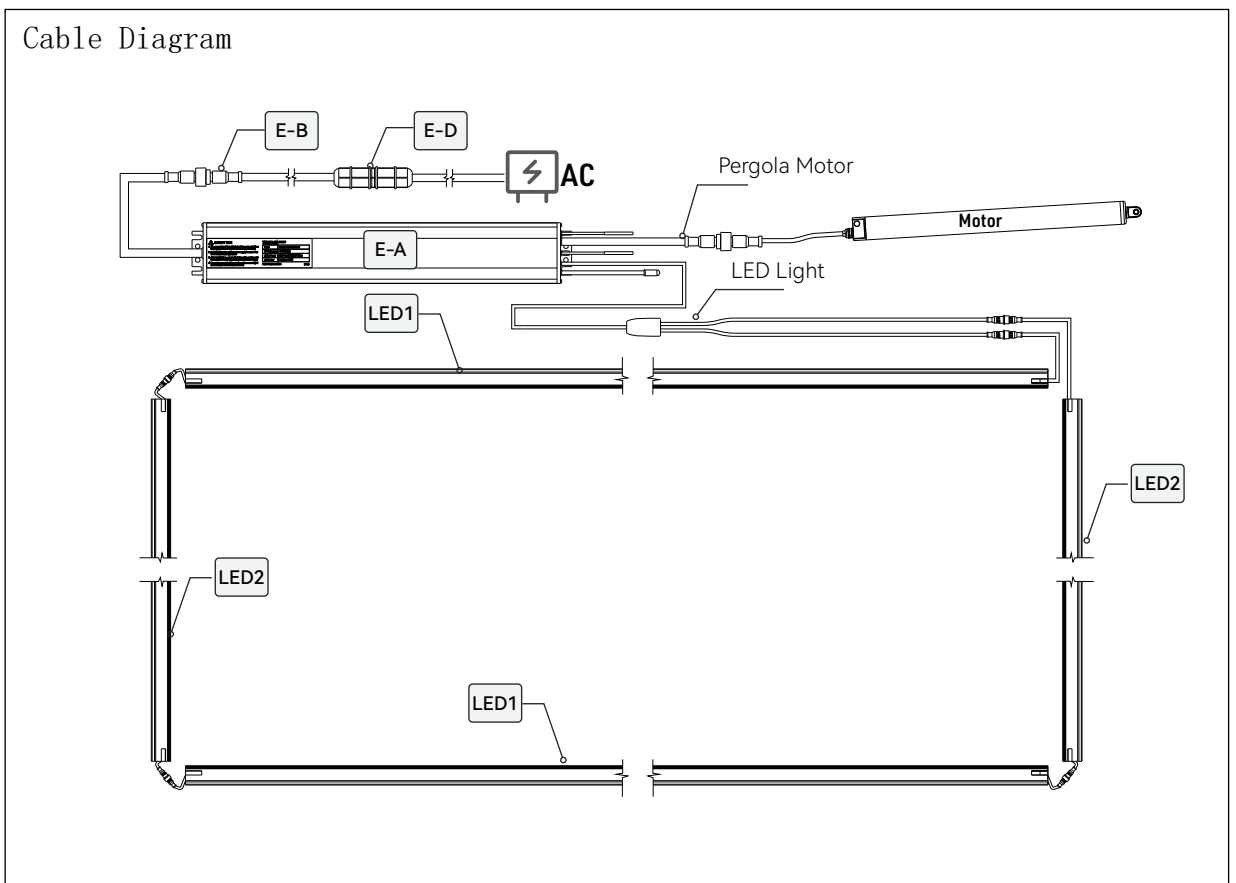

## 3.6X4 ELE & LED

## Montagerichtlinien

### Attention:

1. The controller must be installed inside the side beam, with the input cable routed through the post and exiting through the drainage opening.
2. Insert the controller at least 20 cm deep into the recess of the side beam, ensuring a distance of 40 mm from the end of the beam.
3. The accessories (Sunblinds, Panels) can be secured by screwing it into the beam, 18 cm from the end of the beam.

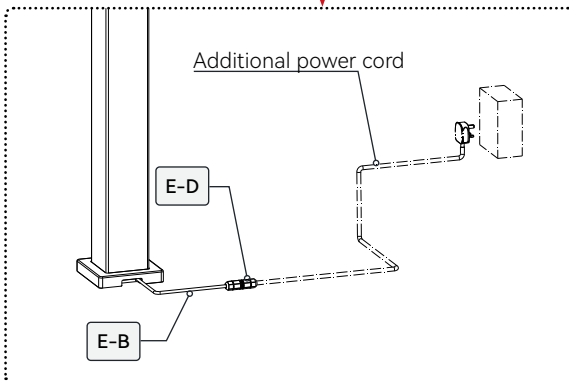
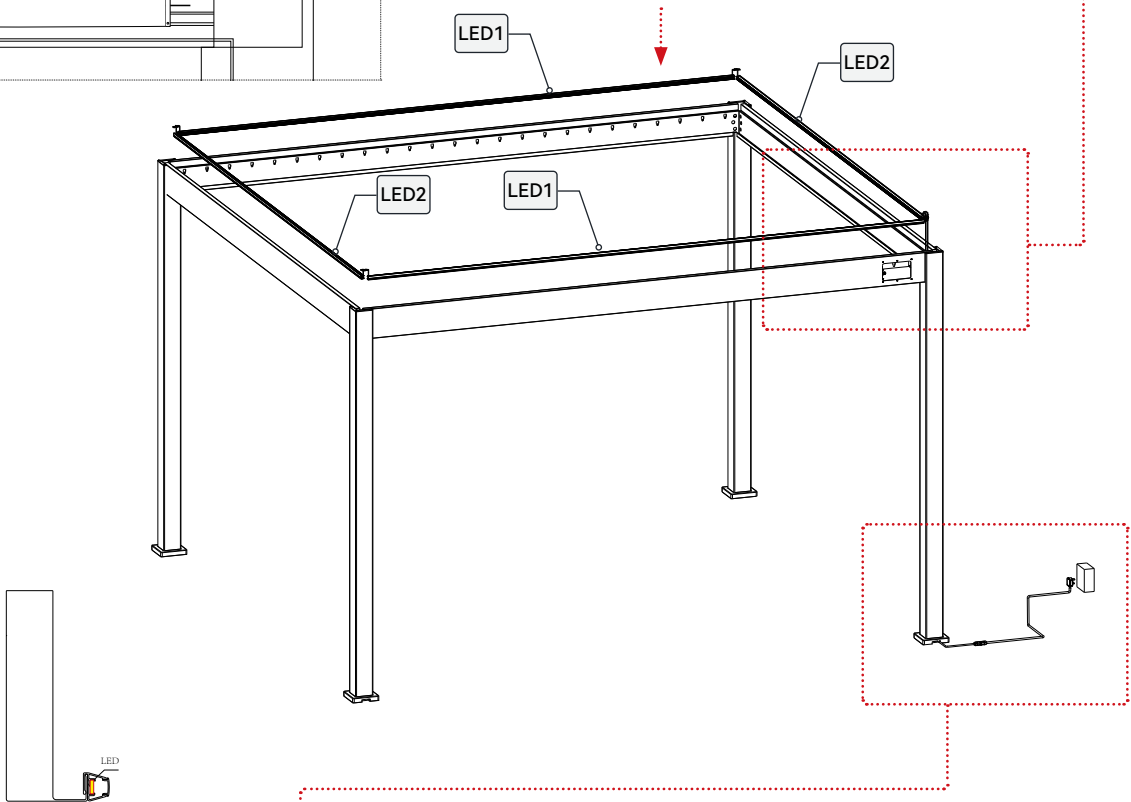
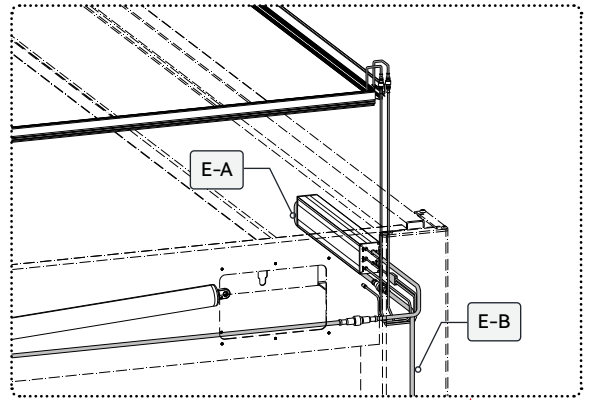
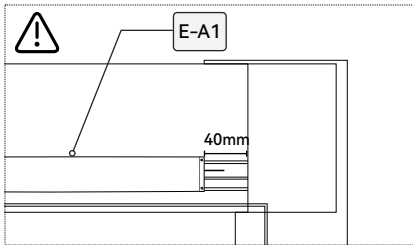



### Attention:



Please select the appropriate power cord based on the country you are in, and connect it using a waterproof connector. This controller can support voltages ranging from 110V to 220V.







There are 3 cables at the input end of the power, namely:  
Brown: LIVE WIRE  
Blue: NEUTRAL WIRE  
Yellow & Green: EARTH WIRE

The illustration uses a manual wrench, which can be replaced with an electric P-tip.

KO		1
LO		24
LO-1		25

MO		49
MO-1		49
VO		49

XO		49
UO		49

ZO-1		4mm
ZO-2		4mm
ZO-5		10mm

### Attention:

Install the spindles for the cover on two ends of the louvers.

Note: To avoid any broken of the plastic parts(MO), when use the pistol drill, please reduce the twisting force of it .



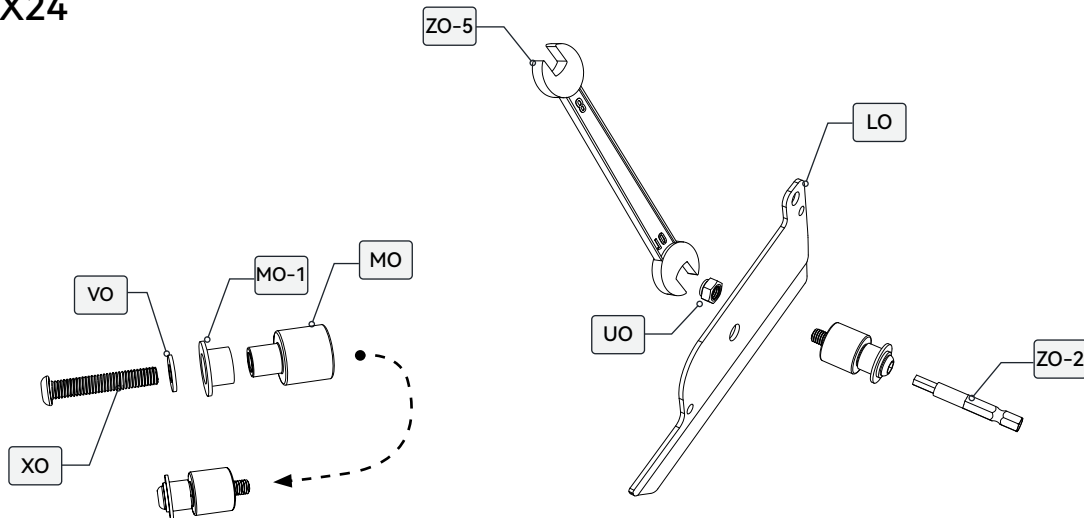

## X24

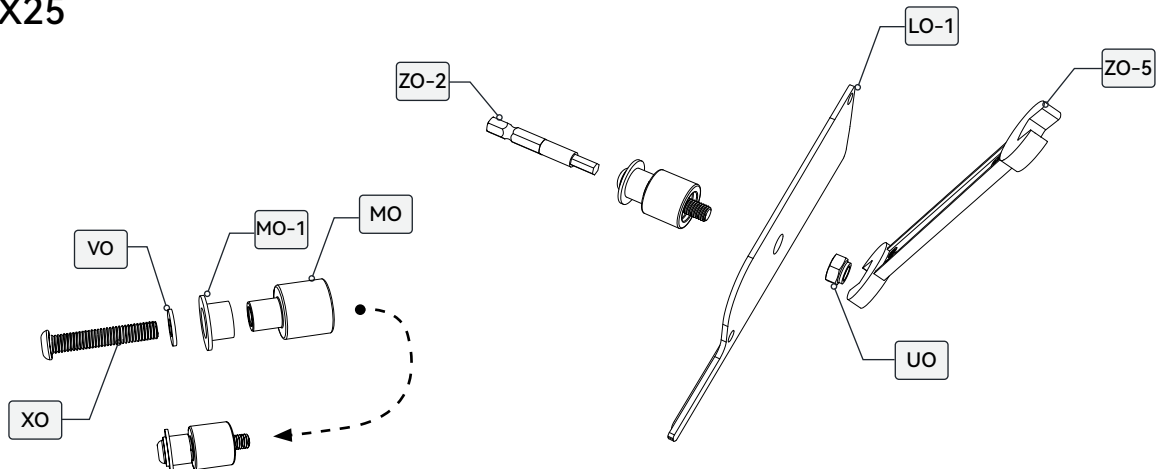

## X25



Install the louvre cover on two ends of the installed louvres and the spindle louvre.

GO		25	WO		4x16		PH2	100	ZO-6		PH2
----	---	----	----	---	------	---	-----	-----	------	---	-----

## X1

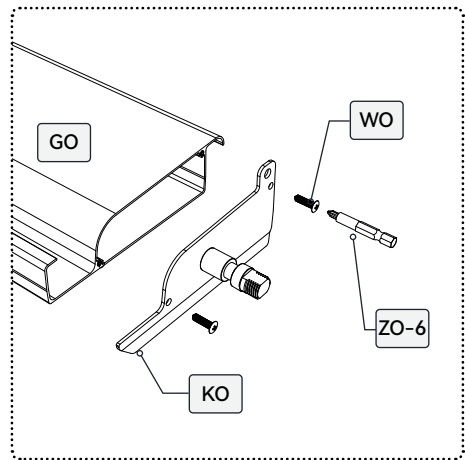
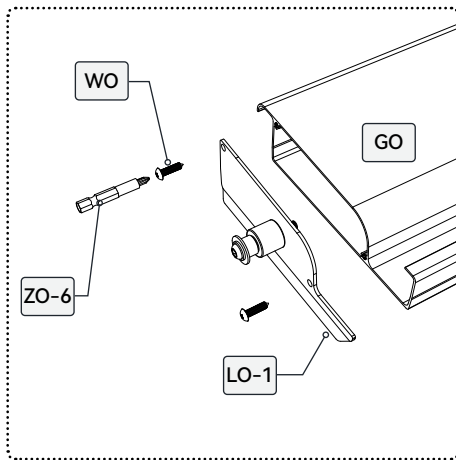

## X24

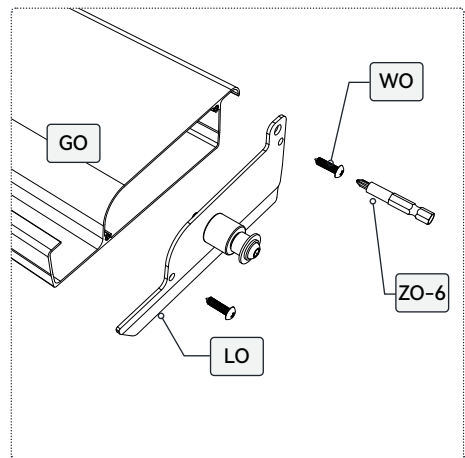
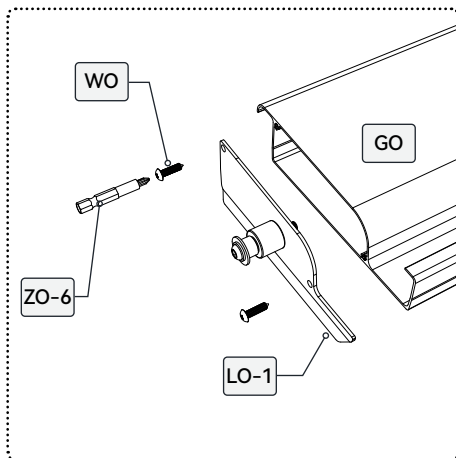

First, connect the input end of the controller to an extension cable, then pass the extension cable through the upright and out from the drainage hole to prevent interference with the subsequent installation of the base plate.

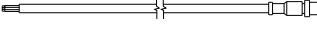
E-A		1
E-B		1

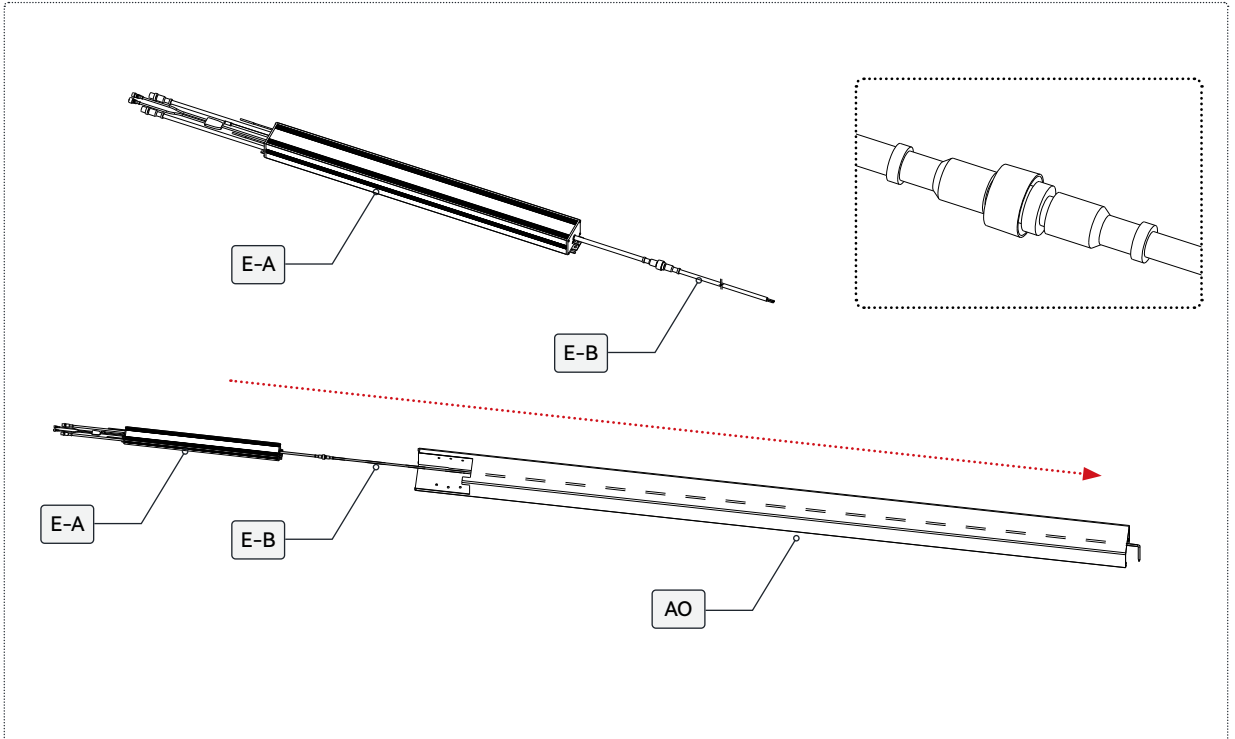





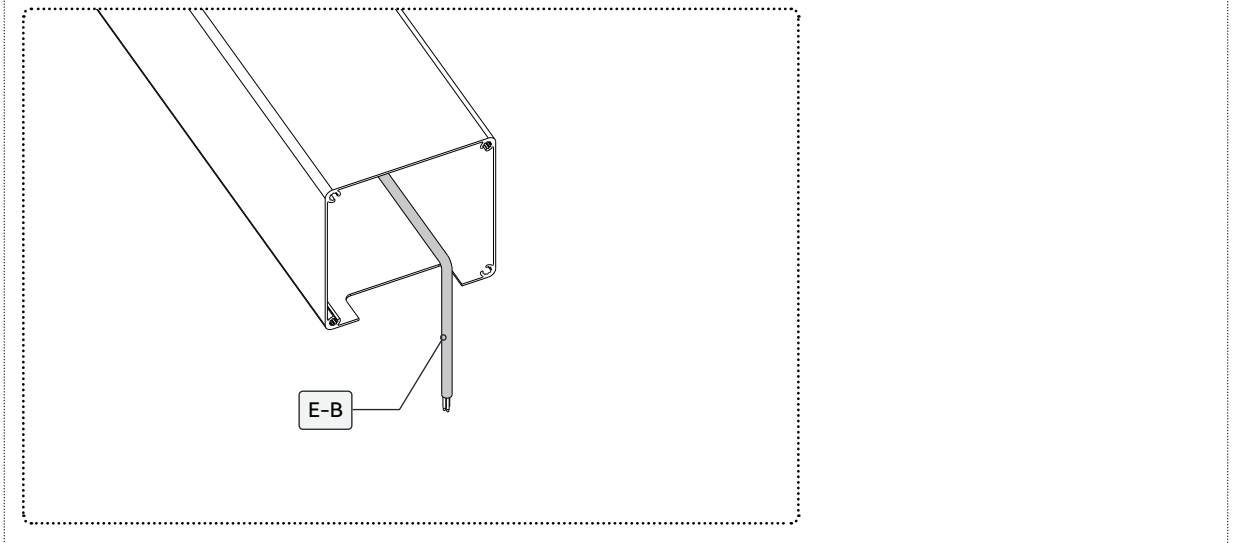

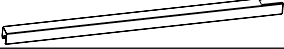

**Attention:**

Please fasten the screw by hand after installing these screws.

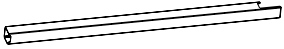

1. Install the post skirt first
2. Make sure the outlet of the skirt and the post are on the same face

AO		2	IO		4	XO-1		16	ZO-1	
AO-2		2	JO		4	WO-3		16	ZO-2	

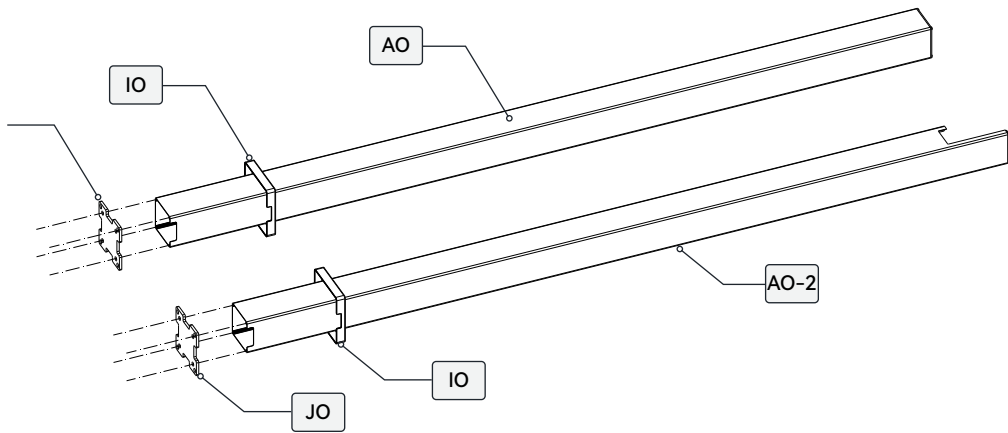

### Attention:

Please fasten the screw by hand after installing these screws.

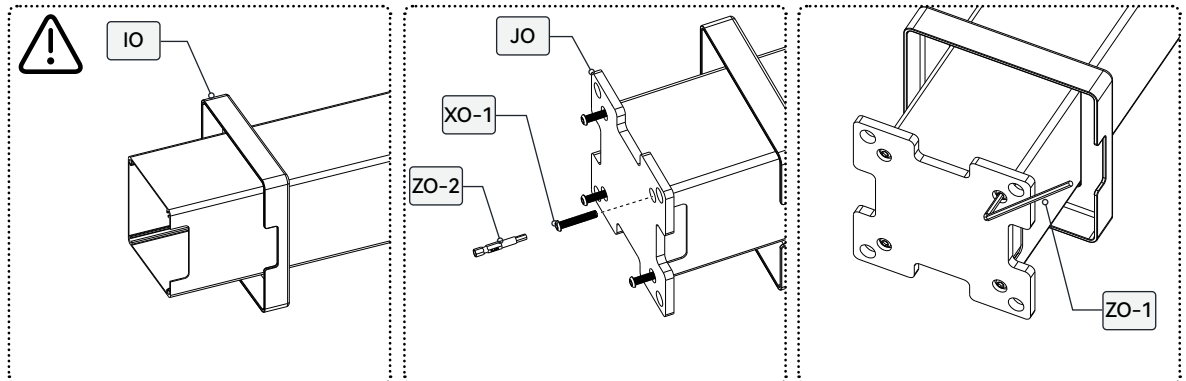



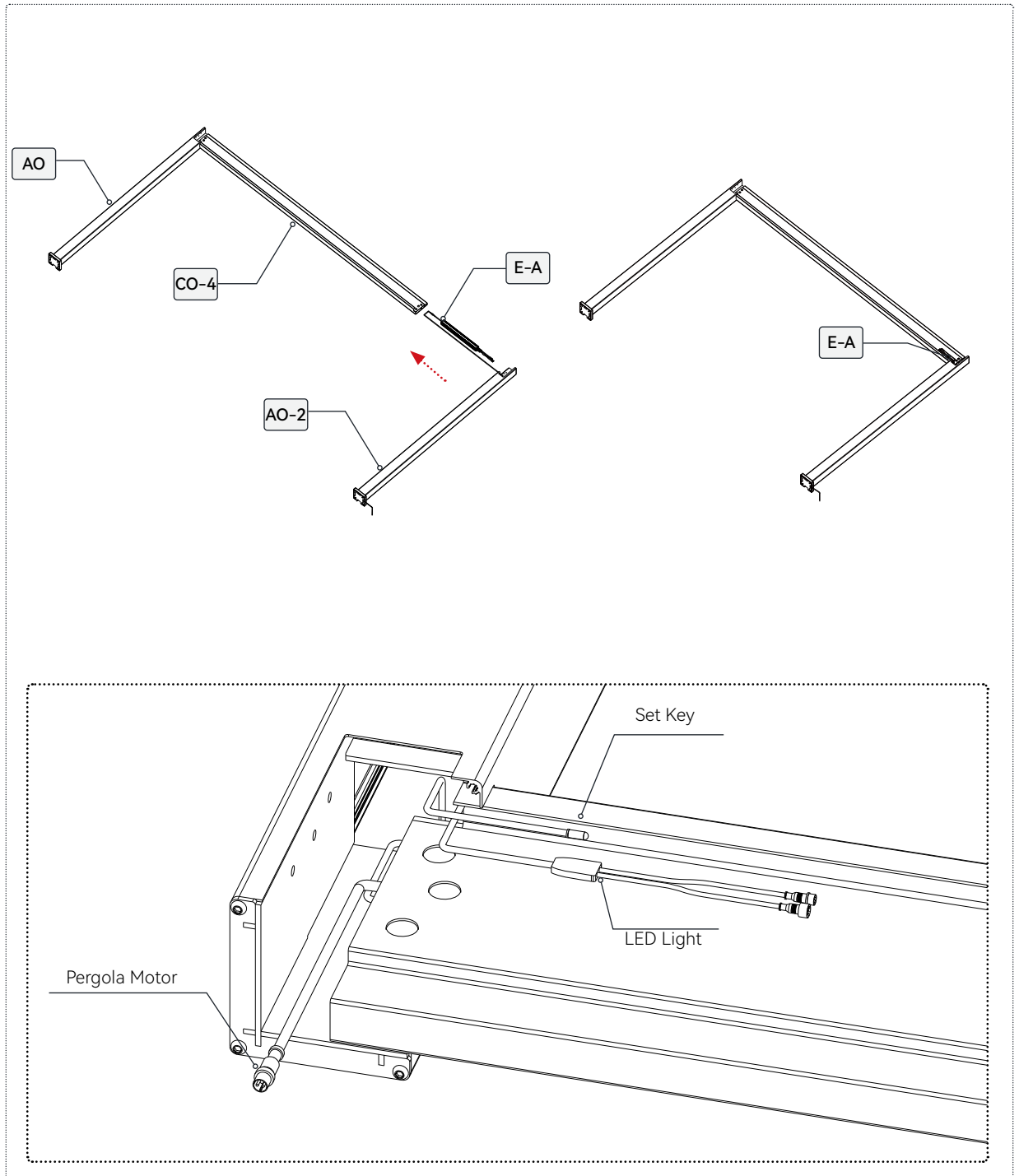

## 3.6X4 ELE & LED

## Montagerichtlinien

Route the appropriate output cables of the controller to facilitate later installation. Ensure that the E-A controller is positioned correctly—at least 20 cm deep from the end of the beam.



Install the screws for the side beams.

CO-3		1	QO			12	ZO-1		4mm
							ZO-2		4mm

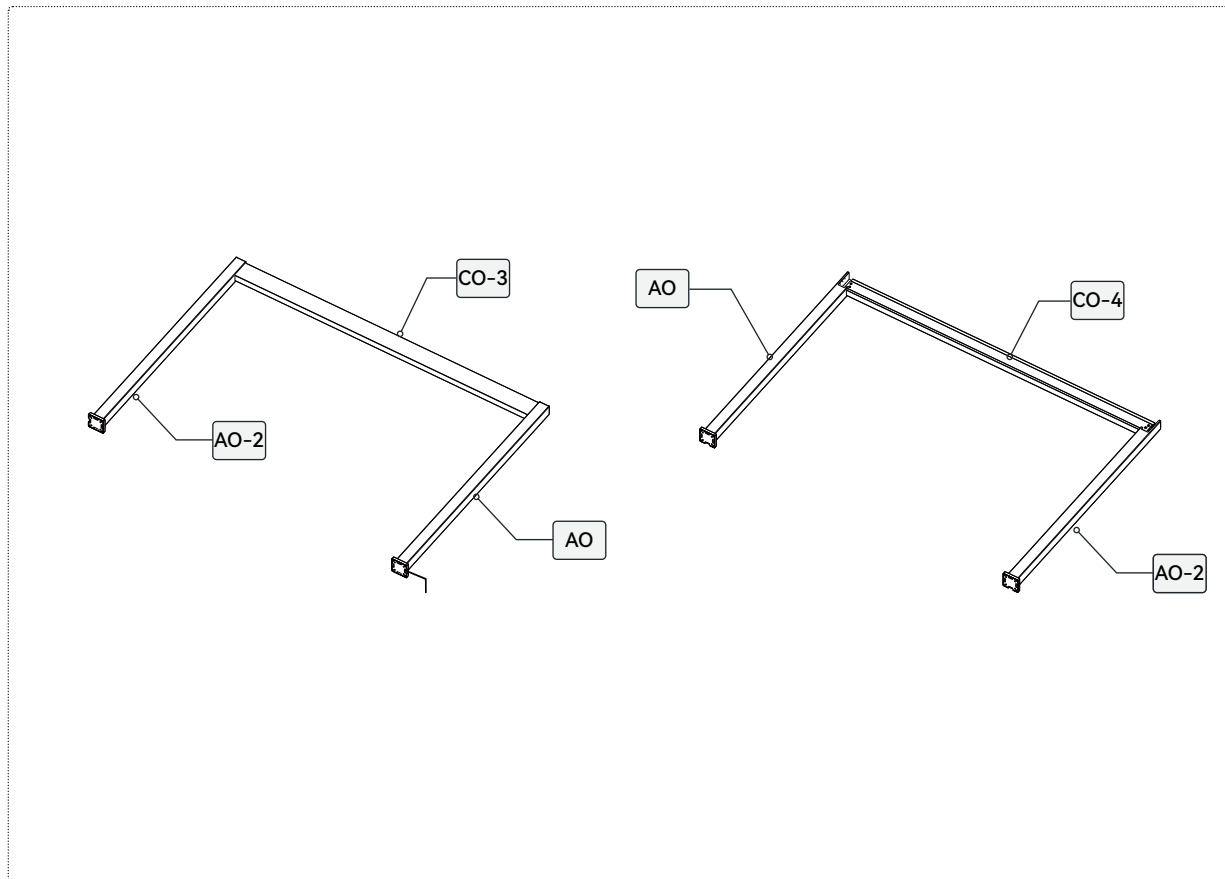

**Attention:**

Please fasten the screw by hand after installing these screws.

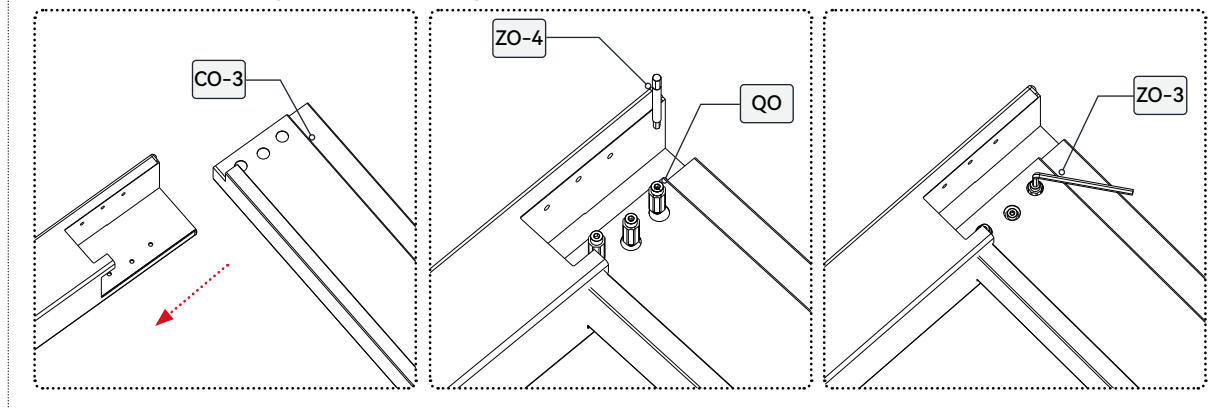



# 3.6X4 ELE & LED

# Montagerichtlinien

First, position the secondary beam, followed by the primary beam, taking care to note the motor connection cable on the primary beam. Then, connect the motor cable from the controller to the motor.

B3		1	QO		6mm	12	ZO-1		4mm
BO-4		1					ZO-2		4mm

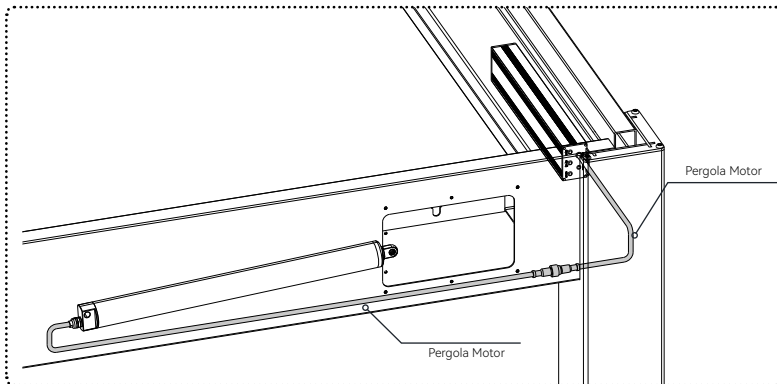
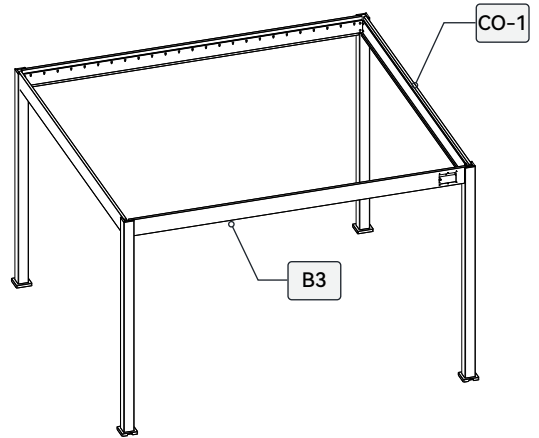
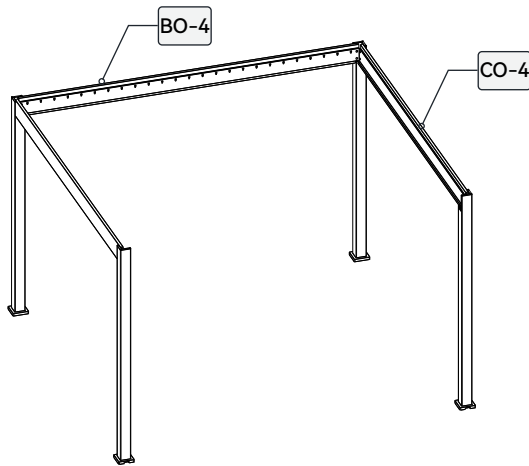

### Attention:

Please fasten the screw by hand after installing these screws.

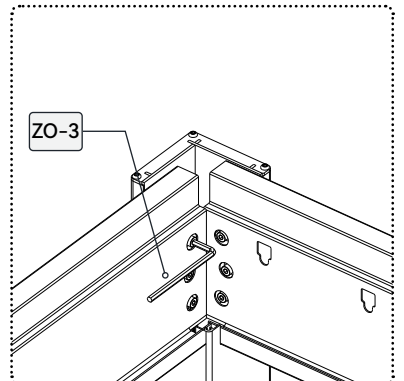
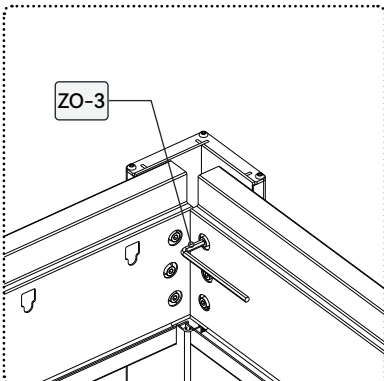
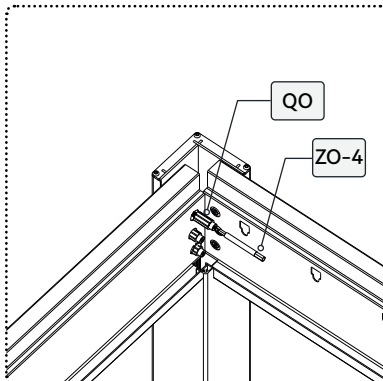

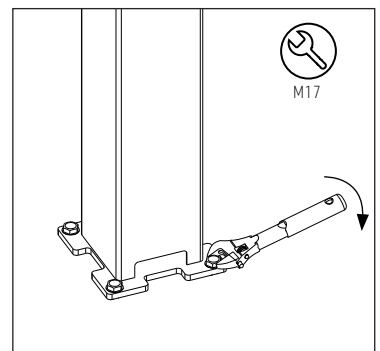
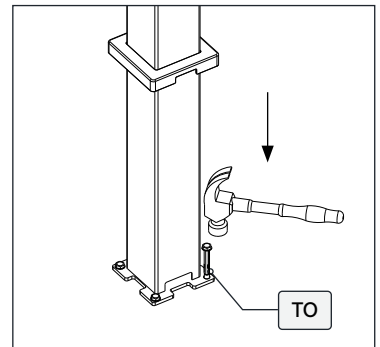
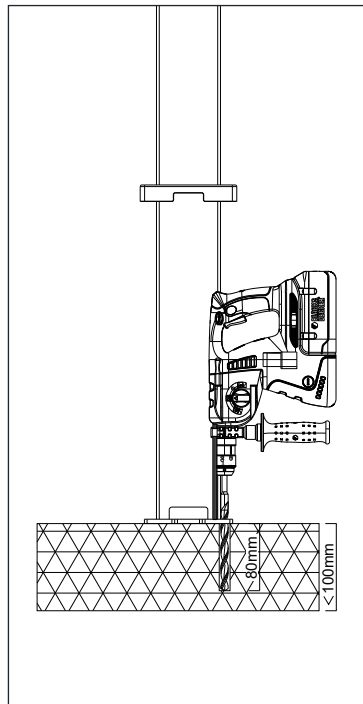
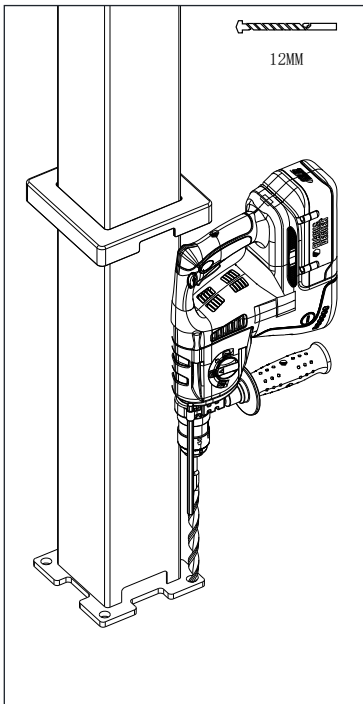
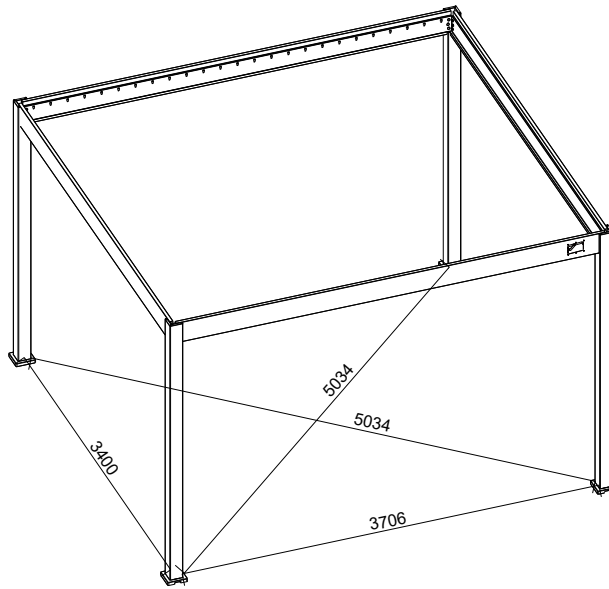

1. Check the dimensions as shown in the diagram.
2. Use a spirit level to ensure all crossbeams are level and the posts are at a 90° angle to the ground.
3. Verify the vertical alignment of the posts.
4. Adjust the lower edge of the columns according to the dimensions in the diagram.
5. Use a 12 mm impact drill to create the holes, then insert the expansion bolts and tighten them with an M17 wrench.

T0	 10x80	16
----	---	----

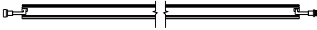

Place the external light strip, connect it to the controller, and link them together in series.

LED1		2
LED2		2

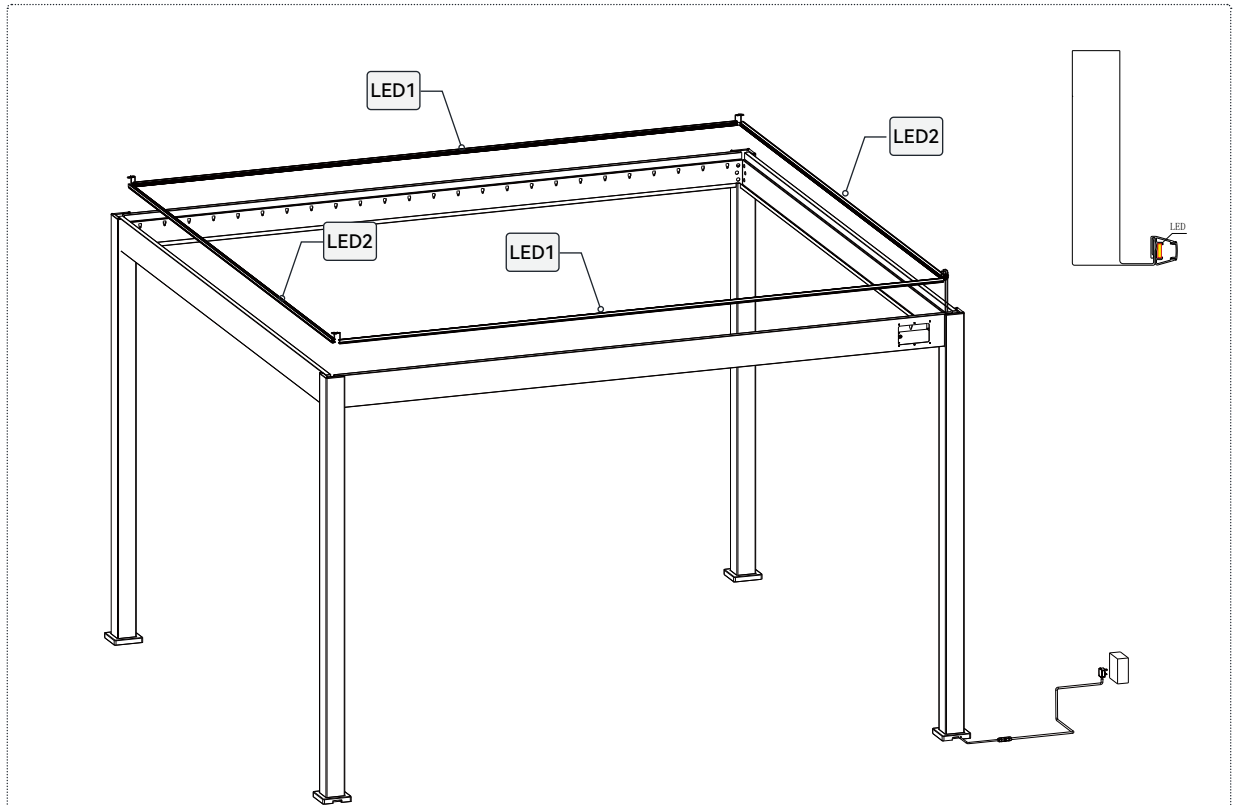

### Attention:

Interconnect the LED strips and connect one segment to the controller's LED terminal. After completing connections, securely route the cables into the drainage port.

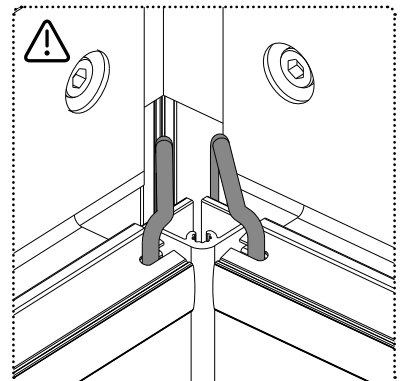
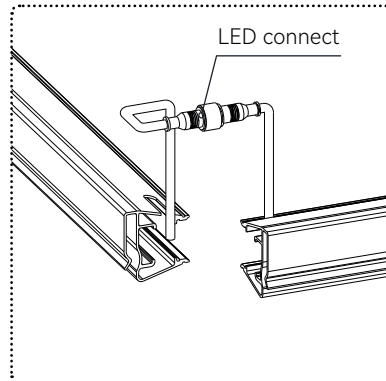
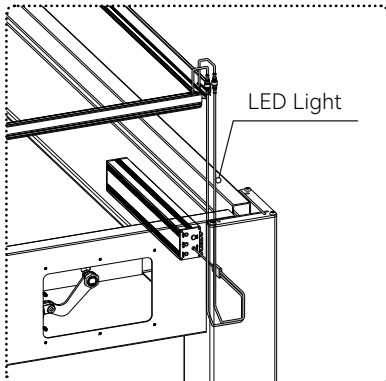

Install the main shaft louvers and secure them using screws. Ensure that the louvers are level.

UO-3	 M14	1
------	---	---

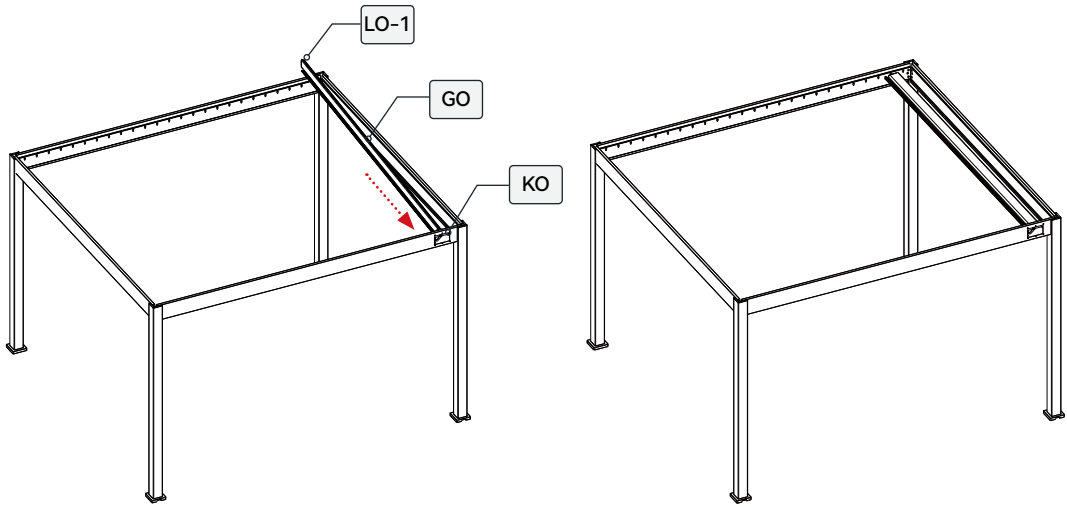

### Attention:

Tighten using a wrench.

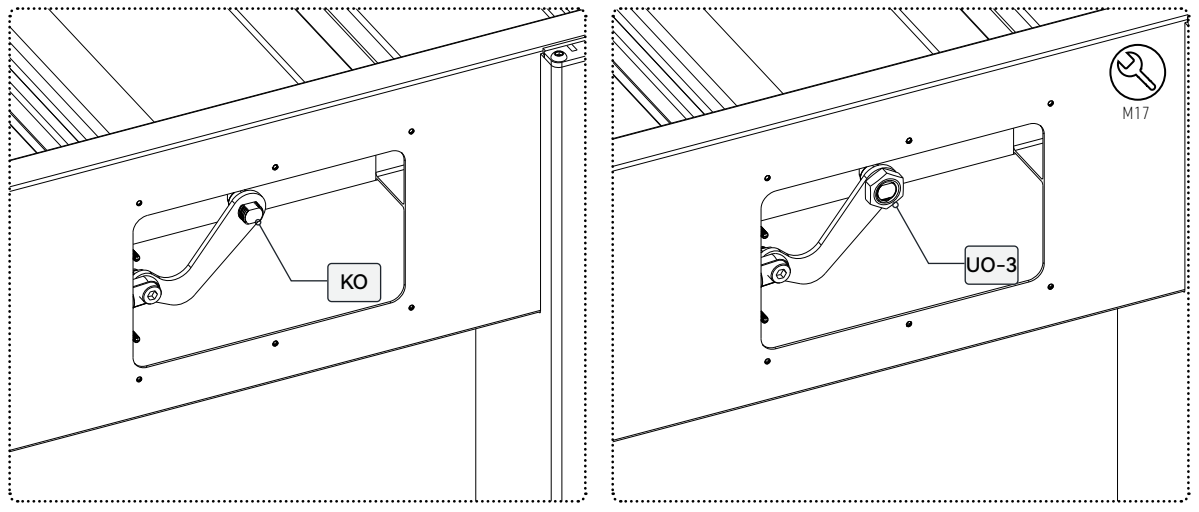

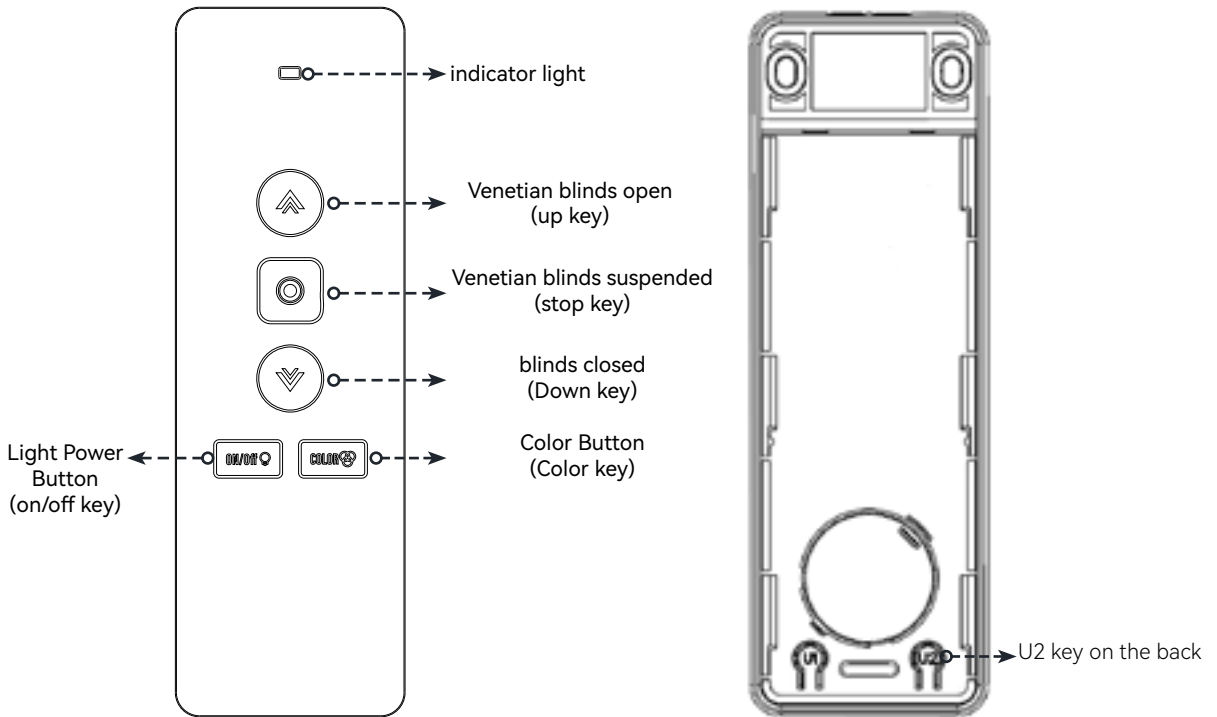

### RGB Lighting Function

**Light Power Button Function:**

Short Press: Cycle control for turning the light on/off.

Long Press (2 seconds): Cycle dimming for brightness, gradually dimming and brightening.

**Color Button Function:**

Short Press: Cycle through 8 color modes: red, green, blue, yellow, cyan, purple, white, and automatic color changing.

Long Press (2 seconds): Gradual color cycling and color adjustment.

The product also supports the TUYA function. The product can be controlled by downloading TUYA. The user must use this function when the WIFI signal is sufficient.

**Reset Network:**

Long press the "SET SKY" on the controller for 7 seconds.

The indicator light will stay off for 1 second, indicating that the network has been successfully cleared.



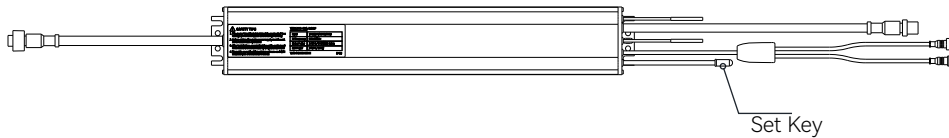

### Remote Control Pairing Guide

Below are two methods for pairing the remote control, clearly organized and easy to follow:

#### Pairing Method 1:

##### Enter Pairing Mode:

Press and hold the "SET KEY" on the controller for 2 seconds. The indicator light will start blinking slowly, indicating that it has entered pairing mode.

##### Complete Pairing:

Press and hold the "Stop key" on the remote control for 2 seconds. The indicator light will stay off for 1 second, indicating that the remote control has been successfully added.

#### Pairing Method 2:

##### Enter Pairing Mode:

Press and hold the "U2 Button" on the back of the already paired remote control for 2 seconds. The indicator light will start blinking slowly, indicating that it has entered pairing mode.

##### Add a New Remote Control:

Press and hold the "Stop key" on the remote control that needs to be paired for 2 seconds. The indicator light will stay off for 1 second, indicating that the new remote control has been successfully added.

#### Notes:

Ensure that the remote control and controller are within the effective operating range.

If the indicator light does not change as expected, repeat the operation or check if the device is functioning properly.

Different brands or models of devices may have different operating procedures. Please refer to the specific device's user manual.

Energize the pergola and manipulate the remote control to rotate the shutters to a 90-degree position, thereby facilitating the subsequent installation of additional shutters.

E-CR		1
------	---	---

Install the battery (purchase separately) into the remote control (E-CR) Tip. The battery model we suggest is CR2450.

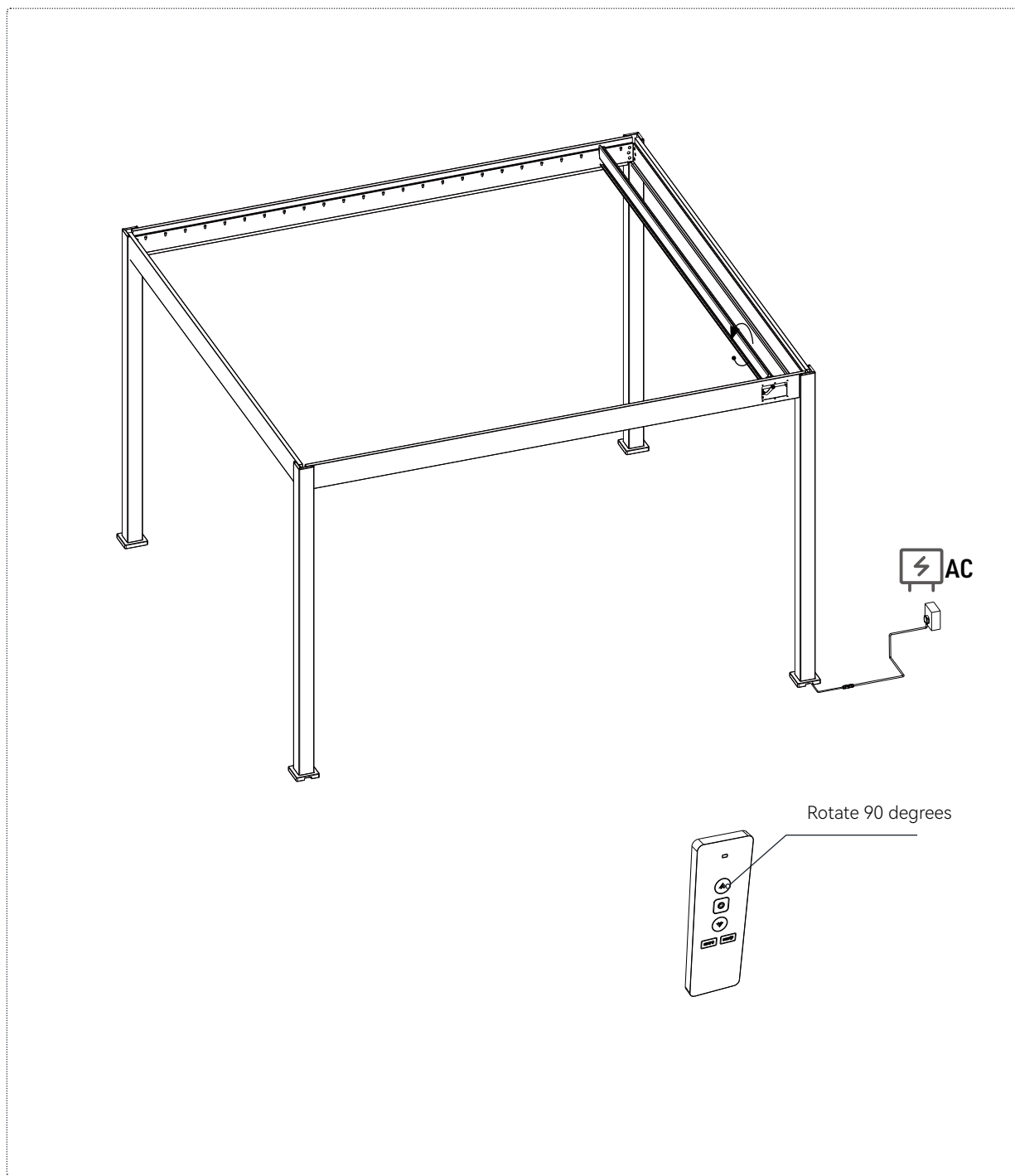

Install the louver for the pergola and attach the end caps on both sides.



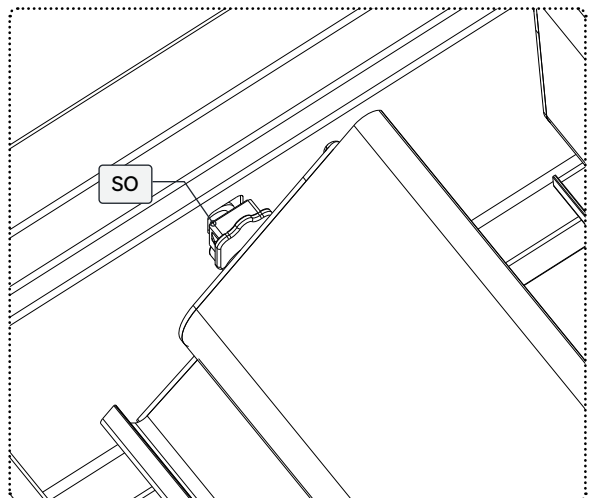
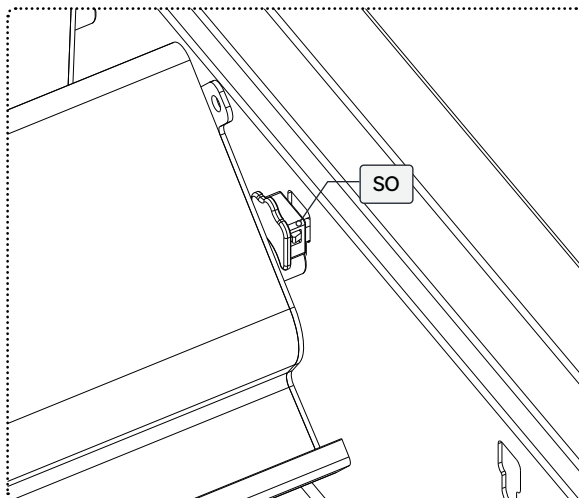
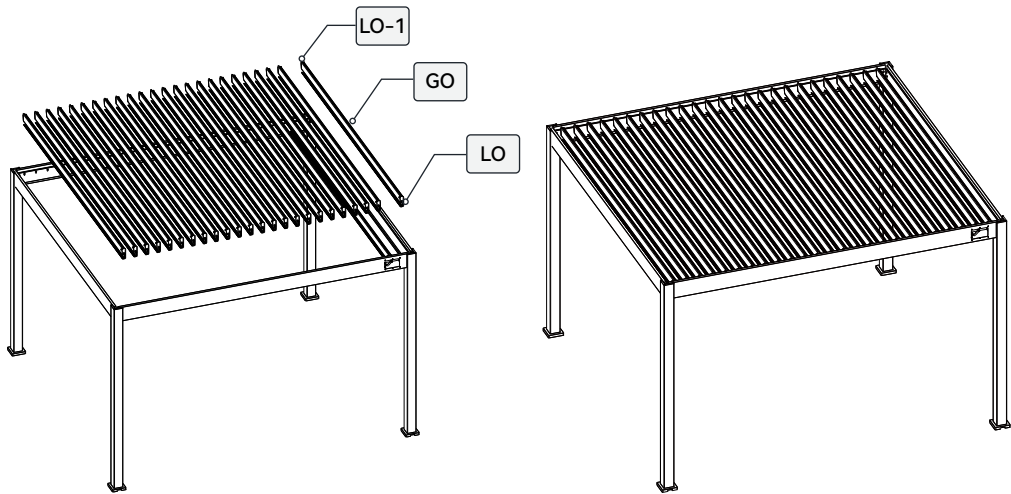





SO		50
----	---	----





Complete the connection of the connecting rod:

1. After assembling the metal locknut "UO," the "XO-2" screw must have a remaining thread protrusion of 2 mm.
2. The "XO-2" screw should remain movable after the full installation of the drive rail "FO."
3. Test the freedom of movement using the Allen key "ZO-1."

FO		1	XO-2			25	UO		25	ZO-1		4mm
							UO-1		25	ZO-2		4mm
							VO		75	ZO-5		10mm

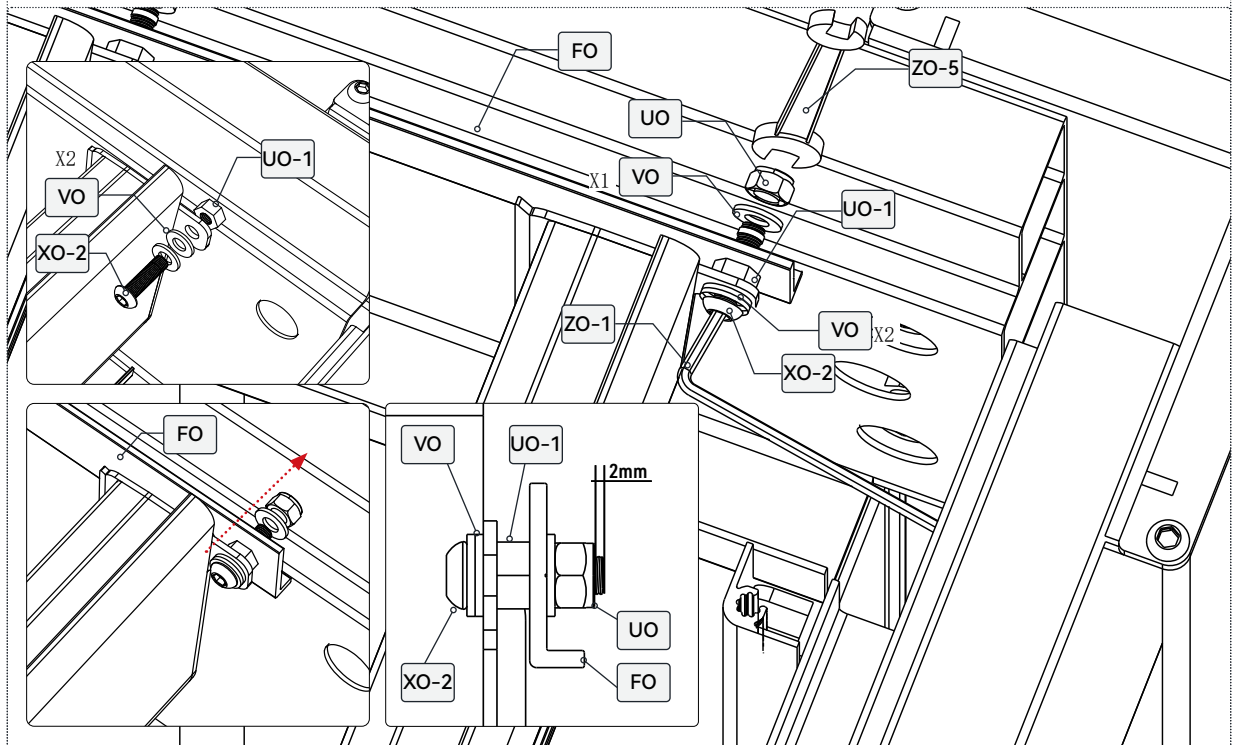
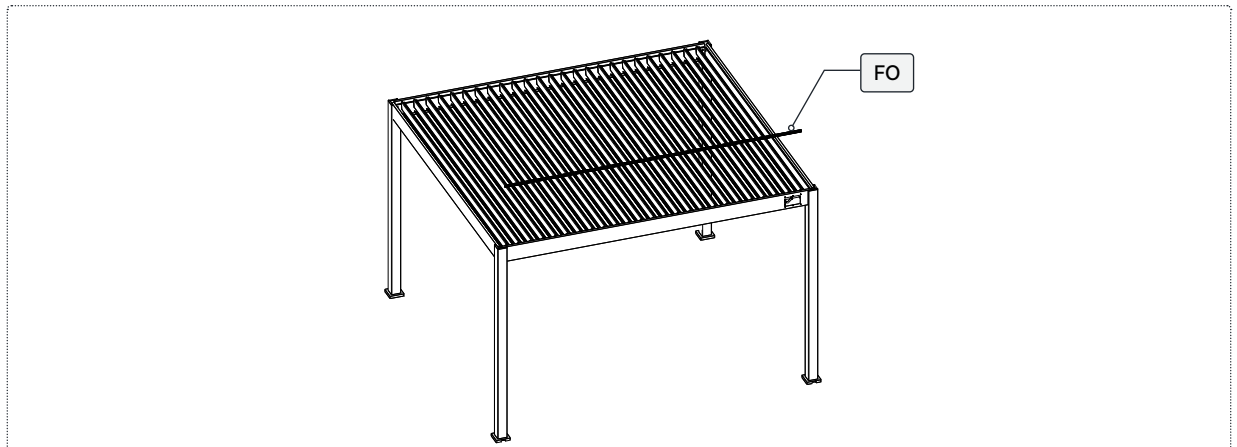

1. Before completing the installation, a function test of the slats is recommended. This helps to identify any damage that may not be visible to the naked eye.
2. Close the slats and ensure that they slide smoothly into each other. There should be no contact, misalignment, or scraping noises between the slats.
3. Install the cover plate and the cap.

